

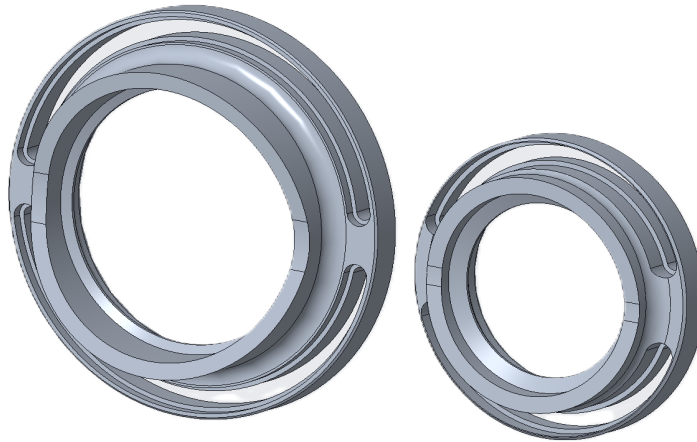

FLAT OUT ASSAULT PATTERN RING INSTALLATION, OPERATING, AND MAINTENANCE INSTRUCTIONS

The following is intended to provide the basic instructions for installation, operation, and maintenance. Read and understand these operating instructions before use.



Read and follow the operating instructions before use.

For firefighting use only.





Product Size:

48635000: For 4863 Assault nozzles

48025000: For 4802 Assault nozzles

PHONE: 330.264.5678 or 800.228.1161 | FAX: 330.264.2944 or 800.531.7335

www.akronbrass.com

 DANGER	• Indicates a hazardous situation which, if not avoided, WILL result in death or serious injury.
 WARNING	• Indicates a hazardous situation which, if not avoided, COULD result in death or serious injury.
 CAUTION	• Indicates a potentially hazardous situation which, if not avoided, may result in minor or moderate injury.
 NOTICE	• Addresses practices not related to personal injury.

 **DANGER**

- Not for use on electrical fires.

 **WARNING**

- Charge all lines slowly to facilitate a controlled water pressure build-up during start-up. Open and close slowly. Rapid opening will produce a sudden thrust. Rapid opening and closing can cause water hammer. Have enough firefighters on the line to safely control the reaction force created by the stream.

 **WARNING**

- At pressures below that indicated on the label, the nozzle will have reduced flow and reach. Be sure you have enough flow and pressure for the situation (See IFSTA and NFPA manuals for guidelines).

 **WARNING**

- The amount of flow to a nozzle is controlled at the pump, not at the nozzle. Therefore, unanticipated increases and decreases in flow can occur without the knowledge of the nozzle operator. This can cause serious consequences (i.e. too little flow to extinguish the fire, or increased reaction force which the nozzle operator may be unable to handle).

 **WARNING**

- Do not use the nozzle in portable hose holders.

 **WARNING**

- Ensure the nozzle is aimed in a direction that is safe.

 **WARNING**

- Ensure the thread on the nozzle swivel is matched to the thread on the hose connection.

 **WARNING**

- Do not use the nozzle as a shut-off when testing hose.

 **WARNING**

- When operating at lower pressures the hose can kink more easily. A kink in the hose chokes off the flow, which may result in inadequate flow for the situation.

 **CAUTION**

- Your nozzle should be inspected prior to and after each use, to ensure it is in good operating condition. Periodically, an unanticipated incident may occur where the nozzle is used in a manner that is inconsistent with standard operating practices and those listed in IFSTA. A partial list of potential misuses follows:

- Operating above maximum rated pressure and flow.
- Not draining, and allowing water to freeze inside the nozzle.
- Dropping the nozzle from a height where damage is incurred.
- Prolonged exposure to temperatures above +130 degrees F, or below -25 degrees F.
- Operating in a corrosive environment.
- Other misuse that might be unique to your specific fire fighting environment.

- There are many "tell tale" signs that indicate nozzle repair is in order, such as:
 - Controls that are inoperable or difficult to operate.
 - Excessive wear.
 - Poor discharge performance.
 - Water leaks.

If any of the above situations are encountered, the nozzle should be taken out of service and repaired, plus tested by qualified nozzle technicians, prior to placing it back in service.

 **NOTICE**

- Do not use the nozzle as a forcible entry tool. Doing so may damage it or make it inoperable.

 **NOTICE**

- If any tags or bands on the nozzle are worn or damaged and cannot be easily read, they should be replaced.

 **NOTICE**

- For use with fresh water or standard firefighting foams only. Not recommended for use with salt water. After use with foam or salt water, flush with fresh water.

NOTICE

- When using with an eductor, make sure the nozzle is properly matched to the eductor. If they are not, the nozzle flow, pressure, and reach may be reduced or the eductor may shutdown. Do not throttle your nozzle with an eductor in the line. This can cause the eductor to shut down.

NOTICE

- The nozzle is configured for optimum performance. Do not alter in any manner.

NOTICE

- Drain the nozzle after use to prevent freeze damage.

Installation Instructions

1. Remove turbine retainer (758354) two socket head screws (767094) using 3/32" Allen wrench. O-ring located under turbine retainer must stay in pattern sleeve groove. This will be used to seal the flat disperse ring.



2. Remove turbine teeth (0772153)



3. Rotate pattern sleeve to wide fog position

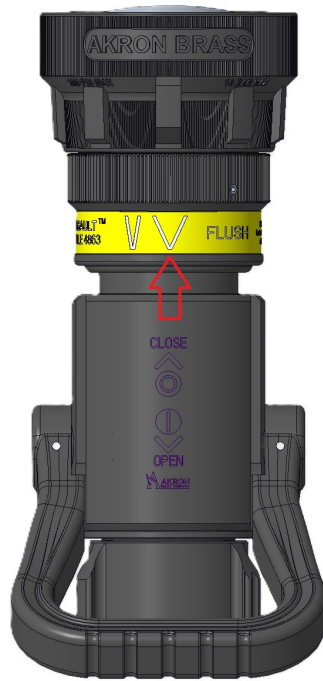

4. Insert flat disperse ring with blank slotted area in horizontal position.

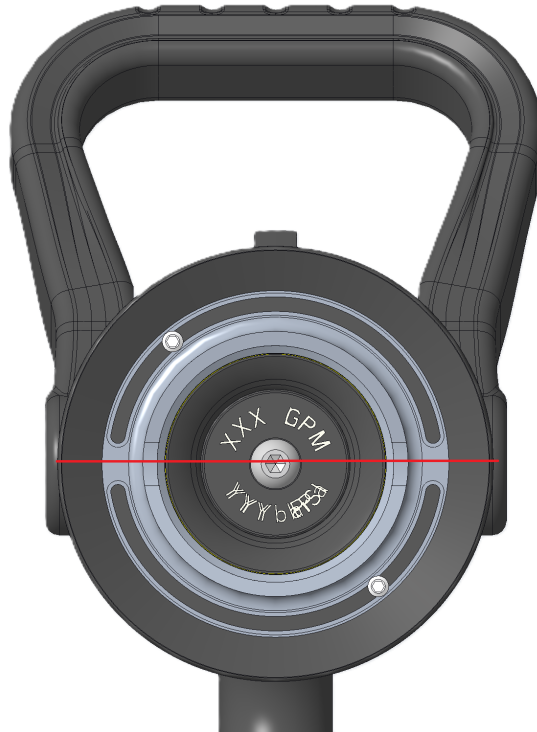

- a. If installing on 4802 nozzle there will be an O-ring (757244) installed on back of flat disperse ring before it gets installed to nozzle.



5. Use new hardware screws (767094) to secure flat disperse ring
6. Rotate the pattern sleeve so the straight stream mark on the I.D band is centered with the on/off marking on the shut-off.
7. Remove yellow I.D band.
8. Remove excess adhesive with suitable cleaner
9. Install new green I.D band, align the straight stream mark on the new green I.D band and center it with the on/off marking on the shut-off.

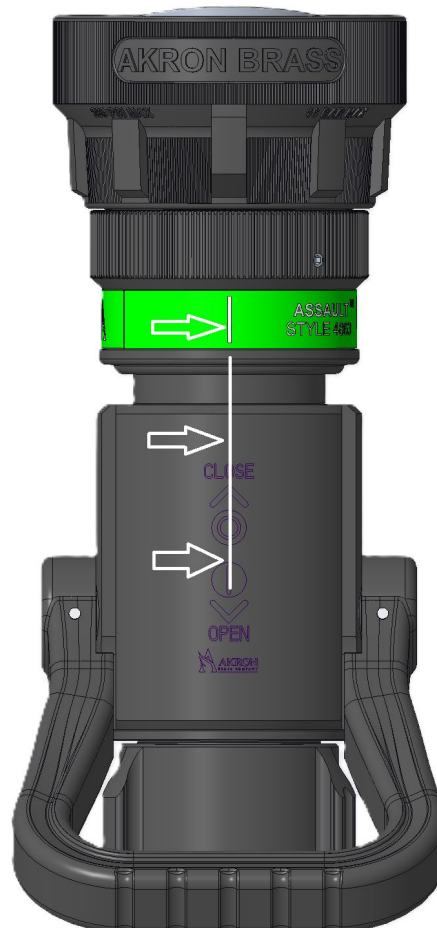

10. Remove FM decal from nozzle. The flat disperse pattern is not an FM approved design.



Operating Instructions

NOZZLE & TIP

- To change the spray angle, rotate the pattern sleeve/bumper. Rotate it clockwise for straight stream and counterclockwise for narrow fog and flat disperse.
- To flush the nozzle, rotate the pattern sleeve counterclockwise past the flat disperse setting. Rotate slowly back to the required setting when obstruction is flushed.
- To determine the required engine pressures to achieve the flow setting, use the following formula: Engine pressure (EP)= Friction Loss (FL) + Nozzle Pressure (NP) + pressure loss or gains due to elevation (1/2 psi per foot of height difference).

Maintenance Instructions

- After use, flush the nozzle with clean water to clean grit and dirt from around exterior moving parts. Doing so will allow the nozzle to operate as designed.
- Over time the seals may need replaced. This can be accomplished by purchasing the appropriate Akron repair kit. Use qualified maintenance mechanics or return the nozzle to Akron Brass for repair.
- Regularly check the baffle screw to be sure it is tight
- Use low temp Lubriplate on metal parts and Parker O-Ring lubricant on O-Rings.