

TECHNICAL MANUAL

**OPERATION, MAINTENANCE, OVERHAUL
AND ILLUSTRATED PARTS LIST**

ROOF TURRET

TYPE 1 & 2



A Member of the **Premier Farnell** Group
An **ISO 9001** Registered Company
P.O. Box 86 1 Wooster, OH 44691
Phone: 330.264.5678 | **Fax:** 330.264.2944

***Note - Hydro-Chem'' information not included. Hydro-Chem™ is a product of Williams Fire & Control.**

TABLE OF CONTENTS

Chapter	Page	Chapter	Page
1 OPERATION AND OPERATOR MAINTENANCE NSTRUCTIONS.....1-1			
Section I. DESCRIPTION	1-1		
1-1 Purpose	1-1		
1-2 Overall Description	1-1		
Section II. OPERATION	1-3		
1-3 General	1-3		
1-4 Roof Turret Instrumentation ...	1-3		
1-5 Operation	1-5		
Section III. OPERATOR INSPECTION AND MAINTENANCE.....	1-8		
1-6 Operator inspection	1-8		
1-7 Troubleshooting Procedures...	1-8		
2 MAINTENANCE AND OVERHAUL			
Section I. INTRODUCTION	2-1		
2-1 Purpose and Scope	2-1		
2-2 Roof Turret	2-1		
2-3 Specifications... ..	2-1		
Section II GENERAL MAINTENANCE INSTRUCTIONS	2-3		
2-4 Introduction	2-3		
2-5 Inspection Prior to Use	2-3		
2-6 In Use Inspection	2-3		
2-7 Maintenance Procedures	2-3		
2-8 Lubrication	2-3		
2-9 Troubleshooting	2-4		
2-10 General Repair Procedures. .	2-4		
Section III .			
REPAIR AND REPLACEMENT PROCEDURES	2-12		
2-11 General Information	2-12		
2-12 Special Tools.....	2-12		
2-13 Roof Turret Assembly			
Removal / Installation	2-12		
2-14 Roof Turret Repair	2-14		
2-15 Roof Turret Nozzle			
Assembly Repair	2-14		
2-16 False Ceiling Replacement..	2-22		
2-17 Pattern and Rate Cable .			
Replacement	2-22		
2-18 Elevation Shaft and Handle Repair	2-25		
2-19 Siamese Repair	2-26		
2-20 Rotation Feedback Assembly Repair	2-26		
		2-21 Rotation Gearbox Assembly Repair	2-27
		2-22 Elevation Gearbox Assembly Repair.....	2-31
		2-23 Elevation Feedback Assembly Repair	2-34
		2-24 Rate Control Assembly Repair.....	2-37
		2-25 Pattern Control Assembly Repair	2-40
		2-26 Solenoid Valve Assembly Repair	2-42
		2-27 Override Valve Assembly Repair	2-44
		2-28 Air Cylinder Assembly Repair	2-46
		2-29 Toggle Valve and Switch Bracket Repair	2-47
		2-30 Air Line Replacement	2-48
		2-31 Circuit Board Repair	2-48
		2-32 Oscillation Limit Control Assembly Repair	2-48
		2-33 Wiring Harness and Power Cable Replacement	2-50
		2-34 Drive Assembly Repair ..	2-50
		2-35 Drain Valve Assembly Repair	2-52
		2-36 Three Inch Valve and Victaulic Inlet Repair	2-53
		2-37 Inlet Waterway Repair ...	2-57
		2-38 Mounting Plate Repair ...	2-58
		2-39 Joystick Replacement	2-58
		3 ILLUSTRATED PARTS BREAKDOWN	3-1
		Section I	
		INTRODUCTION.....	3-1
		3-1 Purpose	3-1
		3-2 Maintenance Parts List	3-1
		3-3 Commercial and Government Entity (CAGE) Codes and Addresses	3-1
		3-4 How to Use the Illustrated Parts Breakdown.....	3-2
		APPENDIX A: Expendable Supplies and Materials List	A-1
		APPENDIX B: Electrical Schematics.....	B-1

LIST OF ILLUSTRATIONS

Figure	Title	Page	Figure	Title	Page
1-1	Roof Turret.....	1-1	3-1	Use of Illustrated Parts Breakdown	3-2
1-2	Roof Turret Travel Limits and Discharge Pattern	1-2	3-2	Roof Turret Installation	3-3
1-3	Roof Turret Control Panel and Joystick Locations	1-3	3-3	Roof Turret Assembly (Sheet 1)	3-4
1-4	Roof Turret Controls and Indicators and Joystick	1-4	3-3	Roof Turret Assembly (Sheet 2)	3-5
1-5	Joystick Roof Turret Control	1-5	3-3	Roof Turret Assembly (Sheet 3).....	3-6
1-6	Roof Turret Manual Mode Controls	1-6	3-3	Roof Turret Assembly (Sheet 4)	3-7
2-1	Roof Turret Location	2-2	3-4	False Ceiling	3-12
2-2	Roof Turret Installation ..	2-13	3-5	Rotation Feedback Assembly	3-14
2-3	Roof Turret Assembly (Sheet 1)	2-15	3-6	Rotation Gearbox Assembly	3-16
2-3	Roof Turret Assembly (Sheet 2)	2-16	3-7	Elevation Gearbox Assembly	3-18
2-3	Roof Turret Assembly (Sheet 3)	2-17	3-8	Elevation Feedback Assembly	3-20
2-3	Roof Turret Assembly (Sheet 4)	2-18	3-9	Rate Control Assembly	3-22
2-3	Roof Turret Assembly (Sheet 5)	2-19	3-10	Pattern Control Assembly ..	3-24
2-4	Pattern and Rate Cable Adjustments	2-21	3-11	Solenoid Valve Assembly ..	3-26
2-5	False Ceiling Replacement	2-23	3-12	Override Valve Assembly ..	3-28
2-6	Rotation Feedback Assembly	2-28	3-13	Drain Valve Assembly	3-30
2-7	Rotation Gearbox Assembly	2-30	3-14	Three inch Valve Assembly	3-32
2-8	Elevation Gearbox Assembly	2-32	3-15	Joystick Installation	3-34
2-9	Elevation Feedback Assembly	2-35			
2-10	Elevation Feedback Assembly Cable Routing	2-36		List OF TABLES	
2-11	Rate Control Assembly ..	2-39	1-1	Operator Inspections	1-8
2-12	Pattern Control Assembly ..	2-41	1-2	Operator Troubleshooting Chart.....	1-8
2-13	Solenoid Valve Assembly	2-43	2-1	Specifications.....	2-1
2-14	Override Valve Assembly ..	2-45	2-2	Inspection intervals	2-3
2-15	Air Lines	2-49	2-3	Lubrication	2-4
2-16	Drain Valve Assembly... ..	2-54	2-4	Troubleshooting	2-5
2-17	Three Inch Valve.....	2-55	2-5	Joystick Electrical Analysis ..	2-59
2-18	Joystick Removal/ installation	2-60			

INTRODUCTION

PURPOSE. This manual provides operation and maintenance instructions for the Akron Brass Type I roof turret assembly.

SCOPE. This manual includes descriptions, operating instructions, troubleshooting information, and maintenance information for this roof turret. No attempt is made to instruct personnel on fire fighting technique.

HOW TO USE THIS MANUAL.

a. Arrangement. This manual is arranged in three sections: operation and operator maintenance, maintenance and overhaul, and illustrated parts breakdown.

b. Table of Contents. The Table of Contents lists all section headings and primary paragraph headings in the manual. Headings are listed by section, paragraph, and page number.

c. I
Illustrations and Tables. Illustrations and tables are included to help make the text of this manual clear. See the List of Illustrations and List of Tables following the Table of Contents.

ABBREVIATIONS. The abbreviations used in this manual conform to MIL-STD-12 and its amendments.

SAFETY SUMMARY

The following are general safety precautions and instructions that people must understand and apply during many phases of operation and maintenance to ensure personal safety and health and the protection of Airport property. Portions of this may be repeated elsewhere in this publication for emphasis.

WARNING AND CAUTION STATEMENTS

WARNING and CAUTION statements have been strategically placed throughout this text prior to operating or maintenance procedures, practices or conditions considered essential to the protection of personnel (WARNING) or equipment and (CAUTION). A WARNING or CAUTION will apply each time the related step is repeated. Prior to starting any task, the WARNINGS and CAUTIONS Included in the text for that task will be reviewed and understood.

COMPRESSED AIR

Use of compressed air can create an environment of propelled foreign particles. Air pressure shall be reduced to less than 30 psi and used with effective chip guarding and personal protective equipment.

DO NOT WEAR JEWELRY

Remove rings, watches, and other metallic objects, which cause shock or burn hazards.

FINGER RINGS

Snagged finger rings have caused many serious injuries. Unless specifically allowed by shop safety procedures, remove finger rings during all maintenance activity.

GIVE CLEANERS/CHEMICALS SPECIAL CARE

Keep cleaners/chemicals in approved safety containers and in minimum quantities. Some cleaners/chemicals may have an adverse effect on skin, eyes and respiratory tract. Observe manufacturer's WARNING labels and current safety directives. Use cleaners/chemicals only in authorized areas. Discard soiled cloths into safety cans.

Consult the local Bioenvironmental Engineer and/or Material Safety Datasheets (MSDS) for specific precautions, protective equipment, and ventilation requirements.

PERSONAL PROTECTIVE EQUIPMENT (PPE)

Wear protective clothing/equipment (gloves, apron, eye protection, etc.) approved for the materials, procedures, and tools being used. Contact supervisor for guidance. If necessary, the Bioenvironmental Engineer or the Base Safety Office should be contacted for guidance.

WARNING SUMMARY

WARNING

Make sure the manual discharge valve handle is disengaged from the valve linkage and secured in the up (stowed) position prior to moving the DISCHARGE VALVE/PATTERN/ RATE switch to the AIR position. Failure to do this could cause the valve handle to swing down when air power is restored, possibly causing Injury.

WARNING

Keep a firm grip on the manual turret control handle when either or both of the turret locking pins have been removed and the turret is discharging water.

WARNING

Make sure the manual turret control handle is removed and stowed in its mounting clip before operating the turret under electrical power. If not removed, it can swing down, possibly causing injury.

WARNING

Compressed air used for cleaning and drying purposes must be reduced to 35 psi and used only with adequate personnel protection and chip guarding

WARNING

Steam or vapor pressure cleaning creates hazardous noise levels and severe burn potentials. Eye, skin, and ear protection is required.

WARNING

Trichloroethane is toxic to skin, eyes, and respiratory tract. Skin and eye protection is required. Avoid repeated or prolonged contact. Good general ventilation is normally adequate.

WARNING

To avoid injury, keep personnel clear of area below turret during removal.

WARNING

Mechanisms in this turret can cause injury to personnel. Keep fingers, hands and tools clear of any moving parts when working on the turret. When working inside the turret, turn off any and all power (air and electric) supplies.

CHAPTER 1. Operation and Operator Maintenance Instructions

SECTION I DESCRIPTION

1-1. **PURPOSE.** This chapter provides operation and operator maintenance instructions for the roof turret. Refer to Figure 1-1. Included is a description, operating instructions, operator troubleshooting information, and operator inspection information for the roof turret.

1-2. **OVERALL DESCRIPTION.** The roof turret may be elevated to reach stated distances. Refer to Figure 1-2 for roof turret travel limits and discharge patterns. The roof turret can be electronically controlled with a pistol-grip joystick located between the driver and the turret operator. The joystick has an index finger-operated button to open the turret discharge valve. Releasing the button closes the valve. A thumb-operated rocker switch on the joystick provides variable pattern control. The turret can also be positioned manually using a mechanical handle stowed next to the turret operator's seat. An azimuth and elevation indicator, pattern controls, and a manual shut-off valve are also connected to the turret through the cab roof.

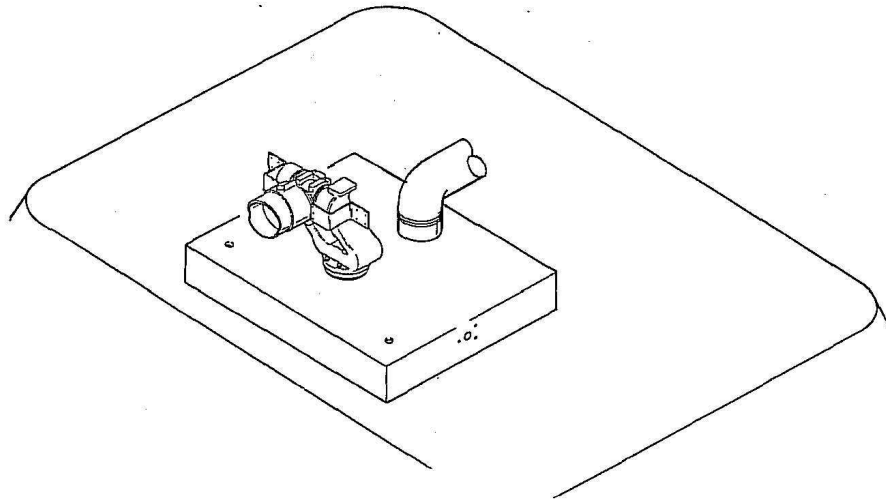

Figure 1-1. Roof Turret.

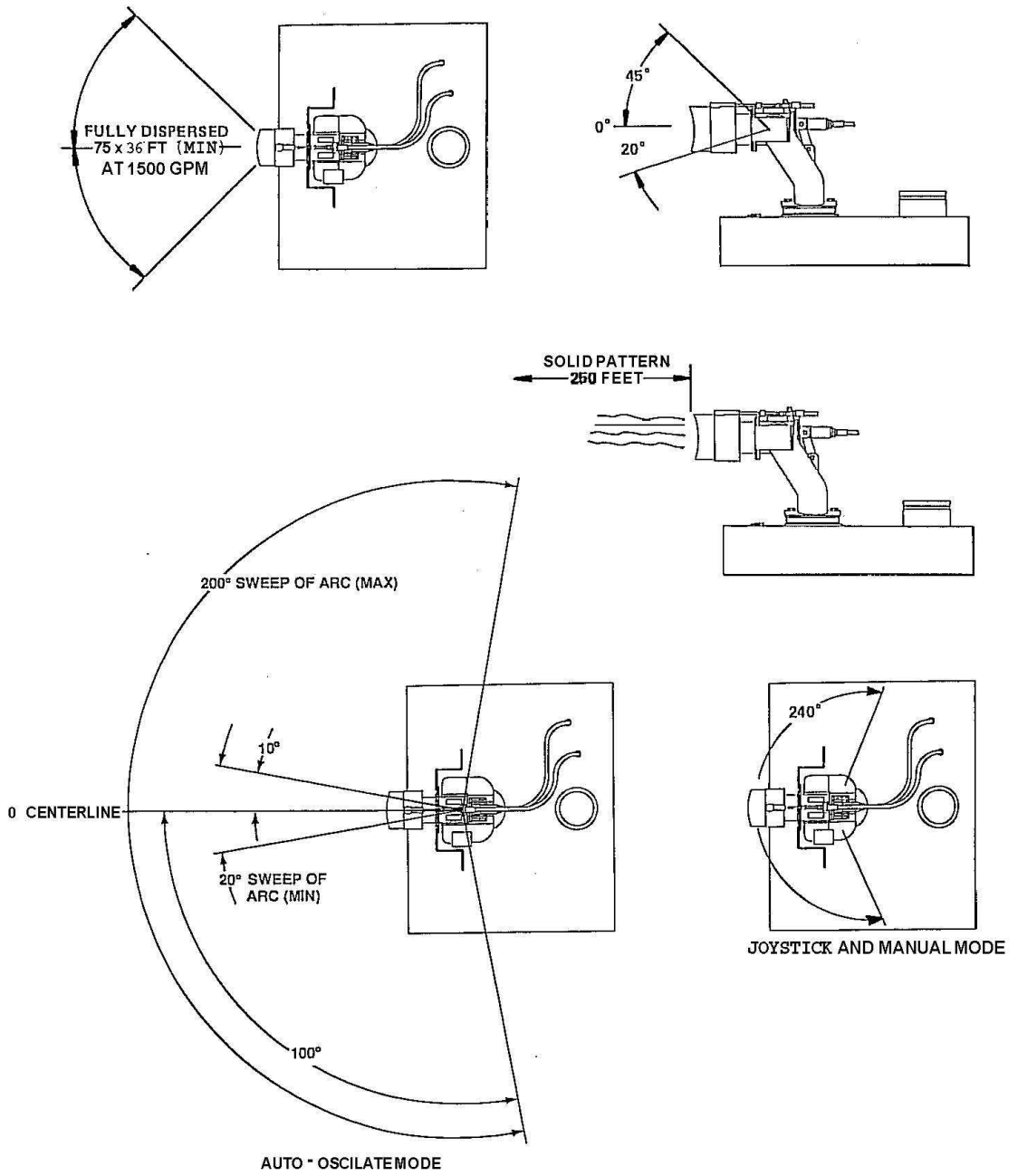

Figure 1-2. Roof Turret Travel Limits and Discharge Pattern.

SECTION II OPERATION

1-3. GENERAL. This section provides instructions for operating the roof turret. P-23 crewmembers must be thoroughly familiar with the contents of this section before attempting to operate the turret. The location of the roof turret control panel and joystick are identified in Figure 1-3.

1-4. ROOF TURRET INSTRUMENTATION. Roof Turret control and indicator layout and description are shown in Figure 1-4.

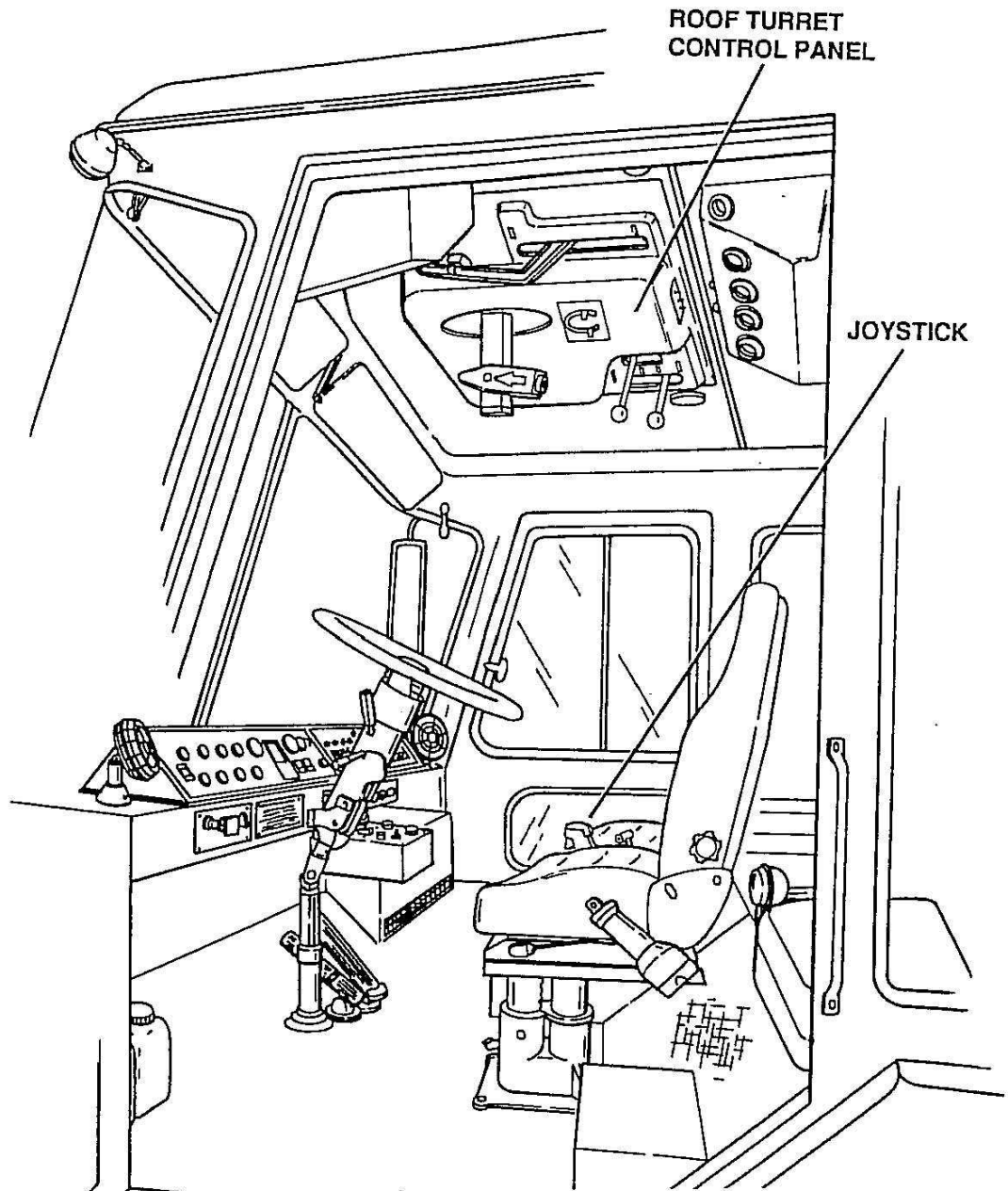
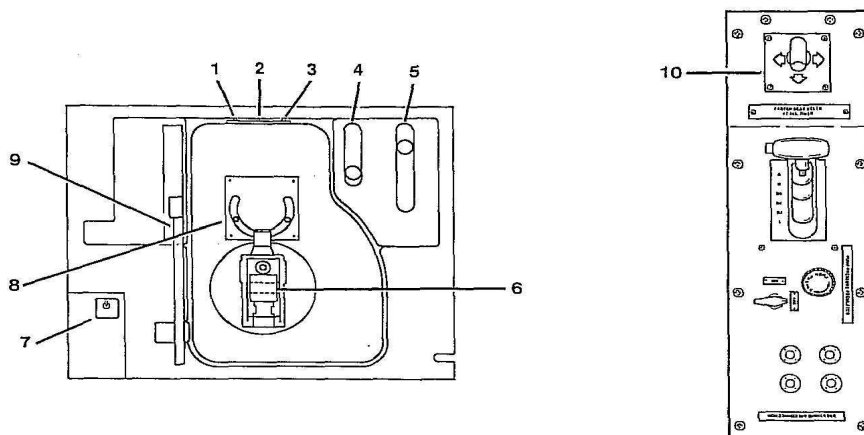

Figure 1-3. Roof Turret Control Panel and Joystick Locations.



1-4. Roof Turret Controls and Indicators and Joystick.

1. **RATE Switch.** Toggle used to select either HIGH GPM or LOW GPM turret discharge rate when in the air-operating mode.
2. **OSCILLATION ON/OFF Switch.** Toggle used to activate or deactivate turret auto-oscillation.
3. **DISCHARGE VALVE Switch.** Toggle used to OPEN or CLOSE agent discharge valve for continuous operation.
4. **Manual Pattern Control.** Lever used to manually adjust pattern of discharge stream between SOLID STREAM and DISPERSED.
5. **Manual Rate Control.** Lever used to manually select HIGH FLOW or LOW FLOW nozzle discharge rate.
6. **Indicator/Manual Handle Holder.** Fixture for holding handle used to aim turret during manual operation. Incorporates azimuth indicator
7. **DISCHARGE VALVE/PATTERN/RATE Switch.** Toggle used to select either AIR or MANUAL mode for controlling agent discharge, spray pattern, and discharge rate.
8. **Oscillator Limit Arms.** Mechanical stops used to set the left and right limits of the turret auto-oscillation sweep from 20° to 200°.
9. **Manual Discharge Valve Handle.** Handle used to manually OPEN and CLOSE the agent discharge valve. From the open position, the handle can be disengaged from the valve linkage and secured in the up (stowed) position.
10. **Roof Turret Control.** "Joystick" controller used in remote electrical operation of the roof turret. Provides left, right, elevate and depress aiming control, pattern control, and a discharge trigger switch.

NOTE

Maintain maximum engine RPM as practicable by modulating throttle and brake pedals for maximum flows.

1-5. OPERATION. Controls for operating the roof turret are located on the cab ceiling and center console (Figure 1-4). The roof turret has three basic operating modes: electronic joystick, auto-oscillating, and manual. Each mode is described separately below.

- a. Electronic Joystick Mode. In this mode, the turret is operated by means of a pistol-grip joystick control mounted on the center console.

CAUTION

When operating in the electronic joystick mode, the manual rate control lever must be fully placed in the low rate or high rate position. Operating the turret between these positions can cause the nozzle to slam into either low or high rate.

- (1) Ensure DISCHARGE VALVE/PATTERN/RATE switch on the roof turret control panel (7, Figure - 4) is in the AIR position.

Example

- (2) Set the RATE switch (1) to the desired discharge rate (750 or 1500 GPM).
- (3) On the fire truck control panel, place the PUMP switch in the ON position. This will activate the agent pump. Associated green indicator light will illuminate. If foam is required, place FOAM switch at the ON position. Associated indicator will illuminate.

- (4) Use the nozzle pattern rocker switch on the joystick control (Figure 1-5) to select the desired discharge pattern (either solid stream or dispersed).

- (5) Use the joystick to aim the roof turret in the direction of application. Direct the turret up, down, right or left to obtain optimum fire control. An elevation/azimuth indicator (6, Figure 1-4) shows turret nozzle position.

- (6) Activate agent discharge by pressing the "trigger" discharge switch on the joystick. This is a momentary switch; discharge will stop when the switch is re-released.

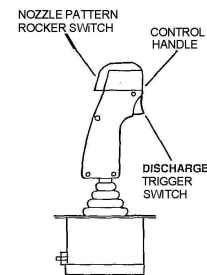

Figure 1-5. JoystickRoof Turret Control.

- (7) When discharge is complete, secure the turret by placing the PUMP and FOAM switches on the fire truck control panel in the OFF position and use the joystick to position the turret pointing straight ahead.

- b. Auto-Oscillation Mode. In this mode, the turret oscillates automatically and continuously through an established arc as it discharges.

- (1) Make sure manual turret control handle is disengaged and stowed. See WARNING above.
- (2) Perform steps (1) through (3) specified above for the electronic joystick mode.
- (3) Place DISCHARGE VALVE switch (3, Figure 1-4) in the OPEN position. The turret will discharge agent continuously.
- (4) Place OSCILLATION switch (2, Figure 1-4) in the ON position. Turret will begin oscillating through the set range of its arc.

(5) Use the oscillator limit arms (8, Figure 1-4) to set the left and right limits of the sweep (20° to 200°)

(6) Use the electronic joystick to direct the turret's elevation and depression to achieve optimum fire control.

(7) When agent discharge is complete, place DISCHARGE VALVE switch (3, Figure 1-4) in the CLOSE position, place OSCILLATION switch (2, Figure 1-4) to OFF, and place PUMP and FOAM switches on the fire truck control panel in the OFF position. This will shut down the auto-oscillating mode. Use the electronic joystick to point the turret straight ahead.

c. Manual Mode. in this mode, the roof turret is aimed and the agent discharge is controlled manually without power assist. This mode is normally used only when air and / or electrical power to the turret is lost. Refer to Figure 1-6.

NOTE

The oscillating limits and turret elevation may be changed anytime during the automatic mode of operation. Automatic oscillation can be stopped by turning off the oscillation switch, or by moving the joystick to either the left or right.

WARNING

Make sure that the manual discharge valve handle is disengaged from the valve linkage and secured in the up (stowed) position prior to moving the DISCHARGE VALVE / PATTERN / RATE switch to the AIR position. Failure to do this could cause the valve handle to swing down when air power is restored, possible causing injury.

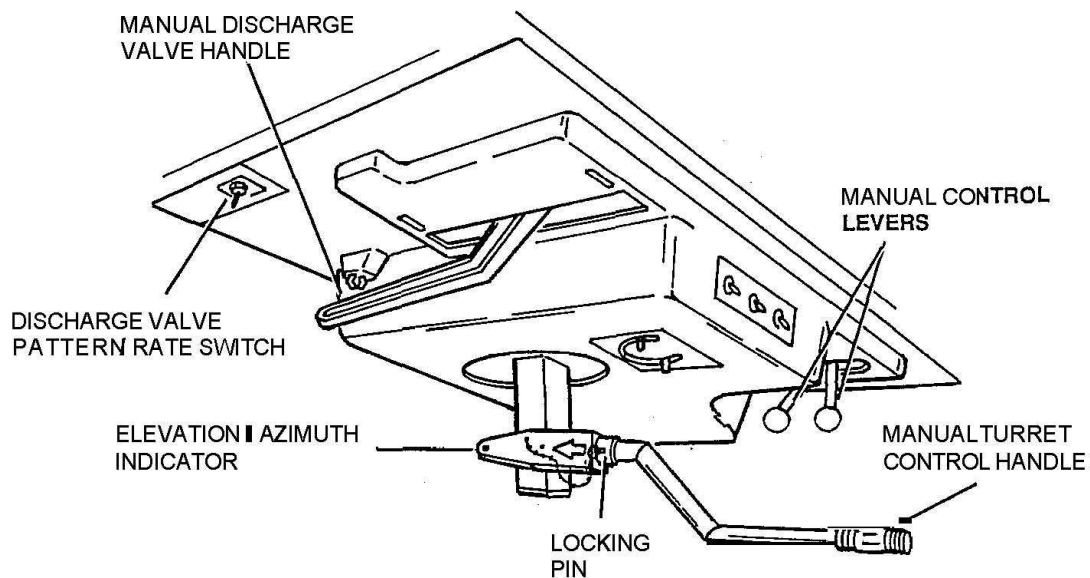

Figure 1-6 Roof Turret Manual Mode Controls.

NOTE

If electric power is available, the turret may still be rotated, elevated, or de-pressed by the joystick or rotated in the automatic oscillating mode. However, since manual control has been selected, the discharge valve, pattern control, and rate control must follow the manual procedure described below.

- (1) Place DISCHARGE VALVE PATTERN / RATE switch (Figure 1-4) In the MANUAL position.
- (2) Remove the manual turret control handle from its stowed location next to the turret operator's seat and install in its holder. Remove elevation locking pin from right side above azimuth indicator. Align lock pinholes in handle and holder. Insert locking pin through manual turret control handle holes.
- (3) Remove the horizontal rotation lock pin and let hang.
- (4) Move the manual pattern control lever to select either SOLID STREAM-or DISPERSED pattern.

NOTE

In manual operation only, an intermediate pattern can be selected by placing the manual pattern control lever to any position between the two extremes.

- (5) Move the manual rate control lever to the LOW FLOW position. Remove the rate lock pin from the stowed position and insert through the three holes in the tension links and the manual rate control lever. Use the manual rate control lever to select the high or low nozzle discharge rate.
- (6) Place PUMP and FOAM (if required) switches on the fire truck control panel in the ON position.

WARNING

Keep a firm grip on the manual turret control handle when either or both of the turret lock pins have been removed and the turret is discharging water.

- (7) Keep a firm grip on the turret control handle while slowly pulling the manual discharge valve handle down to open the agent discharge valve and activate agent flow. Direct the flow using the manual control handle.

NOTE

From the VALVE OPEN position, the manual discharge valve handle can be disengaged from the valve and raised to a stowed position.

- (8) When discharge is complete, secure the turret by moving the manual discharge valve handle to VALVE CLOSE position, place the PUMP and FOAM switches on the fire truck control panel to OFF position, and use the manual control handle to point the turret straight ahead. Remove the control handle from its holder and secure it in its stowed location.

SECTION III OPERATOR INSPECTION AND MAINTENANCE 1-6.

1-7 OPERATOR INSPECTION. The operator inspections listed in Table 1-1 are to be performed daily at the beginning of each personnel change or after each use. Table 1-1 is intended to serve as a guide to maintaining the vehicle in proper readiness condition. The inspections enable operator / crew personnel to detect discrepancies before they lead to roof turret malfunctions. Any defect found must be reported to maintenance personnel.

<p>Table 1-1. Operator Inspections Inspect roof turret for corrosion, damage, or other defects. NOTE</p> <ul style="list-style-type: none"> ▪ Check operation of roof turret during training fires and / or as required by the Fire Department. ▪ Check for proper gage and indicator readings while operating roof turret. <p>Check hose and cable for cuts, cracks, breaks, or damage. Check condition of the nozzle.</p>

1.7. TROUBLESHOOTING PROCEDURES. When a trouble or malfunction occurs, follow these steps. This sequence will help isolate the fault and permit a quicker repair.

NOTE

Isolate the problem completely before starting any remedial action.

a. Duplicate the Problem. Repeat the steps that caused the trouble to occur, unless further damage will be caused. See paragraph 1-5 to be sure the correct operating procedures have been followed.

b. Equipment Description. Read the descriptive paragraph 1-2. Learn how the equipment functions and how it is powered.

c. Troubleshooting. Refer to the troubleshooting chart (Table 1-2). Look under the specific trouble listed in the chart. if the trouble is not listed, refer the truck to maintenance.

d. Checkouts and Remedial Action. Perform the checkout procedures and remedial actions listed in the troubleshooting chart to isolate the problem. When the probable cause or remedial action is not obvious or if the trouble is not cured, refer the truck to maintenance.

TROUBLE	PROBABLE CAUSE	CHECKOUTS PRODURE AND PEMEDIAL ACTION
Roof turret does not respond to electronic joystick control	1. Turret in manual mode	1. Place turret in electronic joystick mode. Refer to paragraph 1-5.
	2. Electrical System Fault	2. Refer to maintenance
Turret does not discharge	1. Pump and Foam switches off.	1. Turn pump and foam switches on.
	2. Turret discharge valve/ pattern/ rate switch is in manual position	2. Place turret in air mode. Refer to paragraph 1-5.

CHAPTER 2. Maintenance and Overhaul
SECTION I
INTRODUCTION

2-1. PURPOSE AND SCOPE

This chapter contains lubrication, troubleshooting, inspection, replacement, repair, and test procedures the roof turret system.

2-2. ROOF TURRET. Figure 2-1 shows the location of the roof turret and joystick mounted on the USAF Type AS32P-23 Crash / Fire / Rescue Truck.

2-3. Table 2-1 lists the specifications for the roof turret installed on the P-23 vehicle.

Table 2-1. Specifications	
Make.....	Akron Brass Type
.....	No aspirating Control
.....	Auto-Oscillating, Joystick, and Manual Control Discharge
Rate.....	750 gal / min (2839 L / min) and
	1500 gal / min (5678 L/min) 180 PSI for Foam or Water
Water or Foam Stream Pattern	250 ft (76.2 m) Water or Foam Dispersed
Pattern (minimum at 1500 gpm)	75 x 35 ft (22.9 x 10.7 m) Nozzle
Elevation/Depressed	20" below Horizontal to 45" above Horizontal Rotation
.....	Manual Mode 120degreesEach Side (240" Total Sweep)

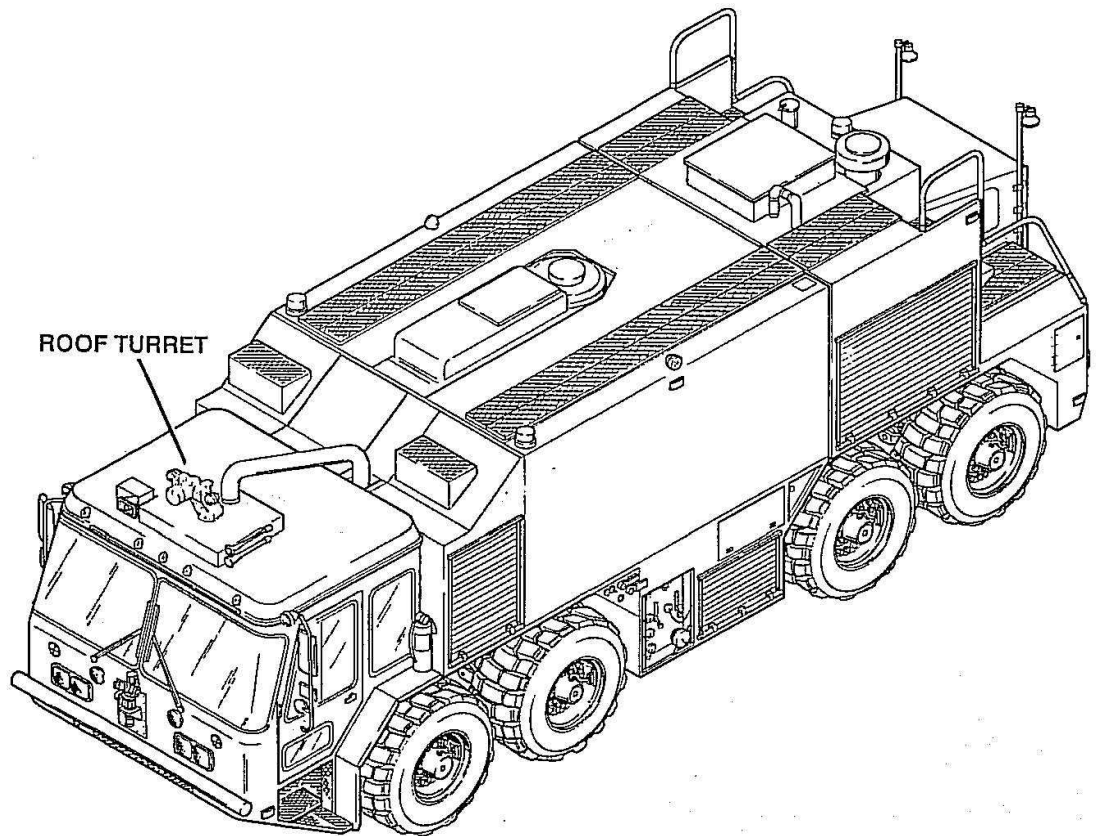

Figure 2-1. Roof Turret Location.

SECTION II GENERAL MAINTENANCE INSTRUCTIONS

2-4. INTRODUCTION.

This section provides instructions for preparing a new or reconditioned roof turret for operation. Also included are instructions for inspecting the turret after shipment.

2-5 INSPECTION PRIOR TO USE

Each turret has received a thorough inspection and complete operational check prior to shipment from the manufacturer. Regardless of precautions taken, some damage may occur to turret during shipment. It is therefore necessary to make a complete visual inspection upon receipt of the turret.

CAUTION

Due to the critical nature of the service for which this turret is intended, no turret should be placed in service if there is any doubt or evidence of improper or inadequate function of any of the components.

1. Inspect turret for shipping damage.
2. Check turret for freedom of operation and proper installation.
3. Check all external inlet connections to see that they are in place and secure.
4. After making all other visual checks, check system for proper operation.

2-6. IN USE INSPECTION.

Table 2-2 lists all inspection intervals. Daily inspections are to be performed by the operator.

2-7. MAINTENACE PROCEDURES

During periodic vehicle servicing, check all mounting and flange bolts and nuts for tightness. Check all air and water connections for leakage.

NOTE

Refer to lubrication chart for further information.

2-8. LUBRICATION

Lubricate turret every six months, 1000 miles, or 200 hours of vehicle operation (whichever comes first). Clean fittings before lubricating. Table 2-3 lists lubricants required and their service intervals.

Table 2-2. Inspection Intervals

Inspection	Inspection Intervals			
	Daily	Periodic		Safety
	Or after Each Use	3 Months 100 Hrs. 200 miles whichever comes first	6 months 200 hrs. 500 miles whichever comes first	Annual 400 hours 1000 miles whichever comes first.
Inspect all piping, fittings and connections for leaks, damage, or corrosion.				X
Check mounting hardware for security and condition.			X	
Inspect roof turret for corrosion, damage, or wear. Replace as needed	X			
Operate roof turret. Check all discharge patterns for water and foam	X			
Lubricant Key				
Intervals	Type of Lubricant	Temperature ranges and lubricant specifications		
		32°F and above	0°F to 32°F	0°F to -40°F
1000 miles 200 Hrs 6 months	Grease, Automotive and Artillery	Lubriplate Low Temp	Lubriplate Low Temp	Lubriplate Low Temp

Table 2-3. Lubrication.

NOTE:

- LUBRICANT KEY Lubrication recommendations are based on an expected duty cycle of 2000 mi. or 400 hours of operation per year.
- Lubriplate is available from: Fiske Brothers Refining Co., Toledo, OH 43605; CAGE: 9N579

2-9. TROUBLESHOOTING. TYPE OF LUBRICANT

When a problem occurs, the following sequence will help in identifying the fault.

- a. Repeat the steps that caused the trouble to occur, unless further damage will be caused. Refer to Chapter 1 to be sure the correct operating procedures have been followed.
- b. Read the appropriate descriptive paragraphs to learn how the equipment functions and how it is powered.
- c. Refer to the specific trouble listed in Table 2-4.
- d. if the defective equipment is part of the electrical air systems, refer to the schematic drawings, Appendix B in this manual to identify the appropriate circuit and its components.
- e. Perform the checkout procedure and remedial actions listed in the troubleshooting charts to isolate the trouble. When the repair or replacement procedure is not obvious, refer to the table of contents in front of this manual to find the proper paragraph.

2-10. GENERAL REPAIR PROCEDURES.

This paragraph describes general procedures that apply to all parts of this manual. To avoid repetition, these procedures will not be described in specific maintenance paragraphs.

a. General Removal Instructions.

- (1) Troubleshooting. Before removing any item, refer to troubleshooting table to isolate problems to a particular component or part.
- (2) Preparation. Before removing any part of electrical, pneumatic, or agent systems, make certain system is not energized or pressurized. Relieve all pressure from air system. Insure that all controls are in OFF position before starting any removal procedure.
- (3) Removal. Make sure there is enough clearance to remove part. Disassemble roof turret or adjacent parts as necessary to provide working clearance.
- (4) Lifting. Use a chain hoist, jack, or other aid when lifting heavy parts. Lifting device should be positioned and attached to part to remove all strain from mounting hardware before part is removed. TROUBLE No roof turret rotation.
- (5) Identification. Identify all parts of similar shape with tags or other markings. This will make proper reassembly easier. Be sure to identify mating ends of electric and air lines as they are disconnected.
- (6) Position of Valves. Before removing valve handles, mark or sketch their position when open and closed. This will help during assembly.
- (7) Salvage Value. Assemblies that are re-moved, even though defective, should be treated as valuable items. Some parts can be rebuilt for future use.

Table 2.4. Troubleshooting

Trouble	Probable Cause	Checkout Procedure and Remedial Action
Roof turret fails to discharge	1. Insufficient air pressure	1. Ensure inlet air pressure is at least 100 PSI and turret regulator is adjusted to 80 PSI
	2. Defective discharge switch on joystick or false ceiling control	2. Replace defective switch
	3. Fault in joystick circuit	3. Perform joystick electrical analysis. Refer to Table 2-5
	4. Defective 4-way solenoid valve	4. Replace solenoid valve
	5. Defective wiring	5. Repair or replace wiring
	6. Defective discharge valve	6. Repair or replace valve
Roof turret discharges intermittently or continuously	1. Defective discharge switch	1. Replace Switch
	2. Defective wiring	2. Repair or replace wiring
	3. Defective discharge valve	3. Repair or replace valve
	4. Defective 4-way solenoid valve	4. Replace solenoid valve
Roof turret leaking water	1. Defective gasket between turret and roof	1. Replace gasket
	2. Worn seals or O-rings within turret	2. Repair Turret
No roof turret rate change	1. Inadequate air supply	1. Repair leaks or restrictions
	2. Defective rate air control	2. Replace rate air control valve
	3. Rate cable not properly connected or adjusted	3. Connect/adjust rate cable
No roof turret pattern control response	1. Inadequate air pressure	1. Repair leaks or restrictions.
	2. No electrical power	2. Check electrical connections to turret
	3. Pattern sleeve O-Rings require lubrication	3. Lubricate pattern sleeve O-Rings
	4. Pattern cable not properly connected or adjusted.	4. Connect/adjust pattern cable
	5. Pattern cylinder solenoid valves defective	5. Replace solenoids
	6. Fault in joystick control	6. Performs joystick electrical analysis. Refer to Table 2-5.
No roof turret elevation or depression	1. No electrical power	1. Check electrical connections to turret
	2. Elevation pin not engaged	2. Engaged elevation pin
	3. Linkage at rear of head binding	3. Correctly position linkage and replace or shim the depression limit spacer at bottom of elevation shaft.
	4. Fault in joystick circuit	4. perform joystick electrical analysis. Refer to table 2-5
	5. Motor or gear box defective	5. Repair or replace motor or gear box

Trouble	Probable Cause	Checkout Procedure and Remedial Action
No roof turret rotation	1. No electrical power	1. check electrical connections to turret
	2. Rotation pin is not engaged	2. Engage rotation pin
	3. Fault in joystick circuit	3. Perform joystick electrical analysis. Refer to table 2-5.
	4. Motor or gear box defective	4. Repair or replace motor or gear box
No roof turret oscillation	1. No electrical power	1. Check electrical connections to turret
	2. Defective oscillation switch	2. Replace oscillation switch
	3. Excessively high current draw on rotation motor (15 amp)	3. Remove obstruction blocking turret movement.

b. General Disassembly Instructions

(1) Cleanliness. The work area for disassembly of any item must be kept as clean as possible. This will avoid contamination of internal parts. This is especially true of control valves, cylinders, and other air system parts. To prevent contamination of system, wipe clean all water and air fittings before disconnecting lines.

(2) Expendable Parts. Whenever possible, all gaskets, packing and seals removed during repair should be discarded and replaced with new parts. These items are usually damaged during removal. In the same way, all lock wire, lock washers, cotter pins, and like items should be replaced at time of assembly.

(3) Removing Seals. When removing gaskets, packing, or seals, do not use any metal tool that will scratch sealing surfaces next to these items.

(4) Disassembly. Before disassembling any item, study the illustration carefully. Carefully study the relationship of internal parts. Knowing the details of construction will speed up disassembly and assembly and help avoid mistakes.

(5) Identification. Apply Identifying tags to mating ends of electric, air lines, etc., when they are disconnected. Identify parts of similar shape to insure correct assembly.

(6) Parts Protection. To prevent moisture and dirt from entering open housings, lines, and other openings, apply protective covers as soon as possible after disassembly. Wrap all parts in clean paper or dip parts in preservative lubricant (8, Appendix A).

(7) Work Required. Remove only those parts needing repair or replacement. Do not disassemble a component any further than necessary.

c. General Cleaning Instructions

(1) Cleaning Solvents. Whenever dry cleaning solvent is recommended for cleaning, use (9, Appendix A). DO NOT USE GASOLINE TO CLEAN PARTS.

WARNING

Compressed air used for cleaning and drying purposes must be reduced to 30 psi and used only with adequate personnel protection and chip guarding.

(2) Removing Deposits. After soaking parts in solvent, wash away deposits by flushing or spraying. Where needed, brush with soft bristle brush moistened in solvent. Use compressed air to dry all parts.

(3) Tools. Do not use scrapers, wire brushes, abrasive wheels, or compounds in cleaning parts, unless called for in detailed instructions. These procedures normally alter size of machined surfaces and may weaken a highly stressed part.

(4) Rubber Parts. Do not clean preformed packing or other rubber parts in dry cleaning solvent. These parts should be wiped with a clean, dry, lint-free cloth.

WARNING

Steam or vapor pressure cleaning creates hazardous noise levels and severe burn potentials. Eye, skin, and ear protection is required.

(5) Exterior Parts. Steam clean all exterior parts thoroughly before removing. This will make inspection and disassembly easier.

WARNING

1,1,1 Trichloroethane is toxic to skin, eyes, and respiratory tract. Skin and eye protection is required. Avoid repeated or prolonged contact. Good general ventilation is normally adequate.

CAUTION

To prevent corrosion, parts should be dipped in preservative lubricant (8, Appendix A) within two hours after degreasing.

(6) Degreasing Machine. A degreasing machine may be used to remove heavy grease and oil accumulations from metal parts. 1,1,1 Trichloroethane is used in this equipment as a degreasing agent.

(7) Electrical Parts. Electrical parts, such as coils, junction blocks, and switches, which use insulating materials, should not be soaked or sprayed with cleaning solutions. Clean these parts with a clean lint-free cloth moistened with dry cleaning solvent.

(8) Painted Surfaces. Wash painted surfaces with a solution made of 1/4 pound of soap chips to 1 gallon of water.

CAUTION

If compartments require cleaning do not use a high pressure hose or large amounts of water to clean. Damage to equipment or compartment could result.

General Inspection Instructions

(1) Sealing Surfaces. Inspect all surfaces in contact with gaskets, packing or seals. Insure that no nicks, burrs, scratches, etc., exist. These might damage new seals during assembly. If any defect is found, correct it as outlined under General Repair instructions before assembly.

(2) Bearings. Check bearings for rusted or pitted balls. Check balls for brinnelling, abrasion, and serious discoloration. The following are causes for bearing rejection:

- (a) Cuts or grooves parallel to ball or roller rotation.
- (b) Fatigue pits (not minor machine marks or scratches).
- (c) Cracks found during magnetic particle inspection.

(3) Inspection. Inspection consists of checking for defects such as distortion, wear, cracks, and pitting. Parts under heavy load or pressure must be inspected more thoroughly. These may require surface temper, magnetic particle, or fluorescent penetrant inspection procedures. Clean all parts before inspection.

(4) Gears. Gear inspection cannot be described in detail here. There are too many differences in size and shape of gears. The following steps can be used to make a general visual inspection of ail gears. Follow all steps listed within repair instructions for final inspection.

- (a) Normal wear. Loss of metal from surface of gear teeth. Wear must not prevent gears from meshing or performing properly.
- (b) Initial pitting. This may occur when a pair of gears is first started in service. It may continue until most high spots have been reduced but still not affect contact surfaces. This pitting is not necessarily serious.
- (c) Destructive pitting. This type of pitting occurs after initial pitting, often at an increasing rate. This will destroy contact area and reduce the gear's ability to carry a load. Rapid destruction will occur with use.
- (d) Abrasive wear. This damage is caused by fine particles imbedded in gear tooth. These particles may come from many sources: Metal detached from gear tooth or bearings, abrasives not completely removed before assembly, sand or scale from castings, or other impurities in the air.
- (e) Scoring. Slight scoring, scuffing, galling or other surface damage is identified by tears or scratches in the direction of sliding. It starts in areas having highest stress and speed, this is usually at tip of teeth.
- (f) Burning. Burning is indicated by discoloration and loss of hardness due to excessive heat: This is caused by too much friction resulting from overload, over speed, lack of backlash, or faulty lubrication. If discoloring can be wiped off with clean cloth, such discoloring usually can be traced to oil-burn stains, which are not serious.
- (g) Rolling. This damage occurs mainly on plastic gears. Rolling is when material is pushed out of shape without breaking off. This is caused by heavy even loads, sliding, and overheating.

NOTE

If gears look faulty in any way, perform a surface temper and / or magnetic particle inspection. Refer to step (8) below.

(5) Tubing and Hose. Check all hose surfaces for broken or frayed fabric, softness, or swelling. Check for breaks caused by sharp kinks or rubbing against other parts of truck. Inspect fitting threads for damage. Replace any part found defective. Following assembly and during initial turret operation, check for leaks.

(6) Electrical Parts. Inspect all wiring harnesses for chafed or burned insulation. Inspect all terminal connectors for loose connections and broken parts.

(7) Metal Parts. Visually inspect all castings and weldments for cracks. Parts that carry a great load should receive magnetic particle inspection. Critical nonferrous parts may be inspected with fluorescent penetrant. Refer to step (9) below.

(8) Magnetic Particle Inspection.

- (a) A magnetic particle inspection may be performed on steel parts which are not easily replaced and only if inspection is deemed necessary. Such steel parts that have been reworked or reground, or parts containing areas where fatigue can be expected, may be tested. Shear sections and reground contact surfaces must show no defects. Any evidence of cracks is cause for rejection. Since some stainless steel materials cannot be magnetized, do not use this inspection on such parts. Once inspection is finished, pass parts through demagnetizing field. Then wash and air blow dry.

NOTE

Magnetizing amperage depends on parts being inspected. For solid section parts, amperage shall be 1000 amps per diameter-inch. For variable diameter thickness, amperage shall be adjusted for diameter inspected.

(b) Parts shall be rejected if there are indications of non-metallic inclusions (foreign body-gaseous, liquid, or solid) longer than one inch; or if indications are closer than 1/8 inch apart. Parts shall also be rejected if the following patterns appear:

1 Bursts. Scattered, short sharp bursts. Bursts are caused by working metals at temperatures that weaken and break the material. Such problems are usually internal. They seldom are detected by magnetic particle inspection until surface is cut to burst area.

2 Flakes. Separate short wavy lines, usually in same general direction. Flakes are caused by improper cooling. Such problems are usually internal. They seldom are detected by magnetic particle inspection until the part is cut open.

3 Grinding cracks. Fine sharp lines, tightly packed. On some surfaces, cracks may be shallow and hard to see. Grinding cracks are usually caused by a glazed wheel. Instead of cutting, the wheel rubs the surface and overheats parts. These are thermal cracks, similar to heat-treat and hardening cracks. Grinding cracks also may be caused by too much load or too much speed.

(9) Fluorescent Penetrant Inspection. Perform fluorescent penetrant inspection on non-steel metallic parts if necessary. Since some stainless steel materials cannot be magnetized, they should receive fluorescent penetrant inspections. After penetrant has been applied and pattern has developed, any evidence of cracks is cause for rejection. The following procedure may be used for fluorescent penetrant inspection:

(a) Clean and warm parts before applying penetrant. A vapor degreaser may be used.

(b) Apply penetrant by dipping, painting, or spraying. All surfaces to be examined shall be completely covered. Penetration time for various materials are included as follows:

1 Aluminum Alloy-no less than 20 minutes.

2 Magnesium Alloy-no less than 20 minutes.

3 Brass or Bronze-no less than 30 minutes.

4 Ferrous Alloys--no less than 60 minutes.

(c) Clean penetrant from all surfaces using slightly warm water. Cool water may be used when necessary, but cleaning time will be longer. Water used to clean surfaces shall be no more than 120°F (49°Celsius) maximum to prevent removal of penetrant from cracks. Pressurized water spray may be used to shorten washing cycle.

(d) Use one of the following methods to dry and develop parts:

1 Wet developer method. When using wet developer, parts must be completely covered with developer by spraying or dipping. Parts must then be dried and developed in a re-circulating hot air drier for 1/2 the penetration time.

2 Dry developer method. When using dry developer, parts must be completely dried before application of the developer by dipping in (or dusting all surfaces with) developing powder. Develop parts for 1/2 the penetration time.

3 No developer method. When no developer is to be used, drying and developing time shall be at least equal to penetration time to allow for sufficient bleeding of penetrant from defects. When needed for additional clarity during inspection, dry developer may be applied to questionable areas by means of a hand powder bulb.

4 Inspect for cracks under black light. Any evidence of cracks is cause for rejection.

5 Clean parts thoroughly with cleaning solvent (9, Appendix A) and lubricate with preservative lubricant (8, Appendix A).

e. General Repair Instructions.

- (1) Burrs. Remove burrs from gear teeth with a fine-cut file or hand grinder.

WARNING

Compressed air used for cleaning will be reduced to 35 psi and used only with adequate personnel protective equipment and chip guarding.

- (2) Exterior Parts. Exterior painted parts may be resurfaced where paint is damaged, or where parts have been repaired, by using an abrasive disc driven through a flexible shaft.

NOTE

Take care to guard other parts of vehicle from abrasive dust. Do not grind near ex-posed working parts. All openings which would allow dust to reach working parts should be masked.

- (3) Surface Preparation. Before resurfacing, scrape off loose and blistered paint from damaged areas. Clean area to be painted by sanding or buffing. Remove left-over cleaning material with all purpose cleaner (10, Appendix A) and dry thoroughly.

- (4) Protecting Parts. During repair operations, protect bare steel surfaces from rusting when not actually undergoing repair work. Dip parts in, or spray them with, preservative lubricant (8, Appendix A). The same protective coating may be applied to other metals, if necessary, to prevent rust. Aluminum parts may require protection in atmospheres having high salt content. Steel parts must always be protected.

NOTE

The above procedure is used with polished and machined steel parts not protected by cadmium, tin, copper, or other plating or surface treatment. Bare metal surfaces must be free of moisture when applied. Acid present in sweat and skin oils may attack steel surfaces if fingerprints, are not removed. Wipe off fingerprints, then dip parts in preservative lubricant after handling.

- (5) Welding. Welding and brazing may be used to repair cracks in external steel parts, such as brackets, panels, and light framework. Such repairs may, however, be more trouble than they are worth. They should be made only when replacement parts are not available. Do not weld or braze castings, running parts, or parts under great stress, except in emergencies.

- (6) Electrical Parts. Replace all broken, worn, or burned electrical wiring. Wires with several broken strands must be replaced. Broken strands will increase the resistance of wire and lower the efficiency of electrical components.

- (7) Hoses. Replace all broken, frayed, crimped, or soft flexible lines and hoses. Replace stripped or damaged fittings.

- (8) Fasteners. Replace any bolt, screw, nut or fitting with damaged threads. Inspect tapped holes for thread damage. If cross-threading or spalling is evident, retap hole for next oversize screw or stud. Retapping will weaken part, or when cost of the part makes retapping Impractical, replace damaged part. Chasing the threads with proper size tap or die may often be enough. Unless otherwise indicated, use Loctite (2, Appendix A) on all threaded fasteners not using locknuts. Use Lubriplate (4, Appendix A) when using locknuts.

- (9) Mounting Holes. Reshape oval mounting holes to round. Drill to receive bushing with required inner diameter. Stake bushing in place with center punch.

f. General Assembly Instructions

- (1) Preparation. Remove grease from new parts before installation as required.

(2) Packing Installation. To install preformed packing, first dovetail groove, then stretch packing and place into position. Rotate part on flat surface. Apply downward pressure to uniformly press packing into position.

(3) Gaskets. To provide added sealing for gaskets, coat both sides with Silicone sealant (11, Appendix A). Remove all traces of previous gasket and sealant before installing new gasket.

(4) Packing Lubrication. Lubricate all preformed packing with a thin coating of grease (1, Appendix A) before installation.

(5) Installation. Refer to tags and sketches made at removal.

(6) Testing. Test operation after installation. Inspect for leaks, vibration, noise, misalignment, or other problems. Recheck after a few days operation.

g. Workmanship and Storage.

(1) Workmanship and Storage. Workmanship. Maintenance practices to be used when following the procedures within this manual shall be of the highest standard. Proper tools for each task should be gathered before beginning work. Work area should be kept clean. New parts should not be laid out where they will be exposed to dirt or dust before installation. Where specific instructions for repair of an item are given, workmanship over and above the level described is encouraged.

(2) Storage. Parts which are to be stored for some time prior to installation should be properly preserved. Bare steel parts should be sprayed or coated with preservative lubricant (8, Appendix A). All parts should be wrapped in plastic sheeting or moisture-proof paper, with all exposed ports plugged or taped to prevent contamination.

SECTION III REPAIR AND REPLACEMENT PROCEDURES

2-11. GENERAL INFORMATION.

The roof turret is an electrically and air operated unit capable of directing a solid or fan discharge at 750 or 1500 gpm. The flow may be directed through 240° rotation, 45° elevation, and 20° depression. In the auto-oscillating mode, turret oscillation may be set anywhere within a 200° range at any specified arc of sweep. The discharge valve is operated by a double acting air cylinder and controlled by a 4-way solenoid valve and two independent electrical switches. If either switch is ON, the roof turret will discharge as long as the momentary switch on the joystick is depressed or while the DISCHARGE toggle switch is at ON. The stream pattern is controlled by a cable attached to a double-acting air cylinder. The air supply to the cylinder is controlled through two 3-way solenoid valves. The three-position rocker switch on the joystick activates the solenoid valves. The rate at which the sleeve moves is controlled by needle valves on the exhaust line for each end of the cylinder. The discharge direction is changed by electric motors with spur gear or screw drives. These motors are activated in the proper direction by micro switches in the joystick. The discharge rate is changed by moving the baffle. Oscillation is controlled by a circuit board which compares inputs from the rotation feedback assembly with the data determined by the settings on the oscillation limit assembly.

2-12. SPECIAL TOOLS.

Special tool (part no. 7-18-152) is used to install the gear on the shaft when assembling the elevation gearbox assembly and the rotation gearbox assembly. This tool may be procured from:

Akron Brass Company
343 Venture Blvd
Wooster, OH 44691

Special tool (Certi-Crimp, part no. 901 23-2) is used to crimp contacts on wire when assembling plug assemblies. This tool may be procured from:

AMP, inc.
Harrisburg, PA 17105

2-13. ROOF TURRET ASSEMBLY REMOVAL/INSTALLATION.

NOTE

Individual roof turret components can be replaced without removing the complete turret assembly. However, if repairs are significant enough to require bench work, or if the assembly is to be replaced, follow the procedure described below for roof turret removal and installation.

a. Removal. Refer to Figure 2-2 unless otherwise indicated.

(1) Perform the following steps inside cab.

- (a) Remove false ceiling (5), and handle (6). If required, remove grip (7) from handle.
- (b) Drain fire truck air system and disconnect air lines from override valve assembly (71, Figure 2-3).
- (c) Disconnect truck drain hose from drain valve assembly (124, Figure 2-3).
- (d) Disconnect power cable and joy-stick cable from circuit board and remove cables from roof turret mounting plate (paragraph 2-33).

(2) Perform the following steps in the area above the truck cab.

- (a) Disconnect siren.
- (b) Remove four clamps attaching wind-shield coolant manifold to cab.
- (c) Remove roof turret supply line and seal at victaulic inlet (131, Figure 2- 3).
- (d) Swing roof turret supply line aside to provide clearance for turret removal.
- (e) Remove 22 screws (2), nuts (3) and washers (4) attaching turret to cab roof. Discard gasket (8).
- (f) Install four eyebolts in tapped holes at each comer of turret (1).
- (g) Attach hoist to eyebolts and lift turret from cab.

TYPE 1 TURRET VIEW

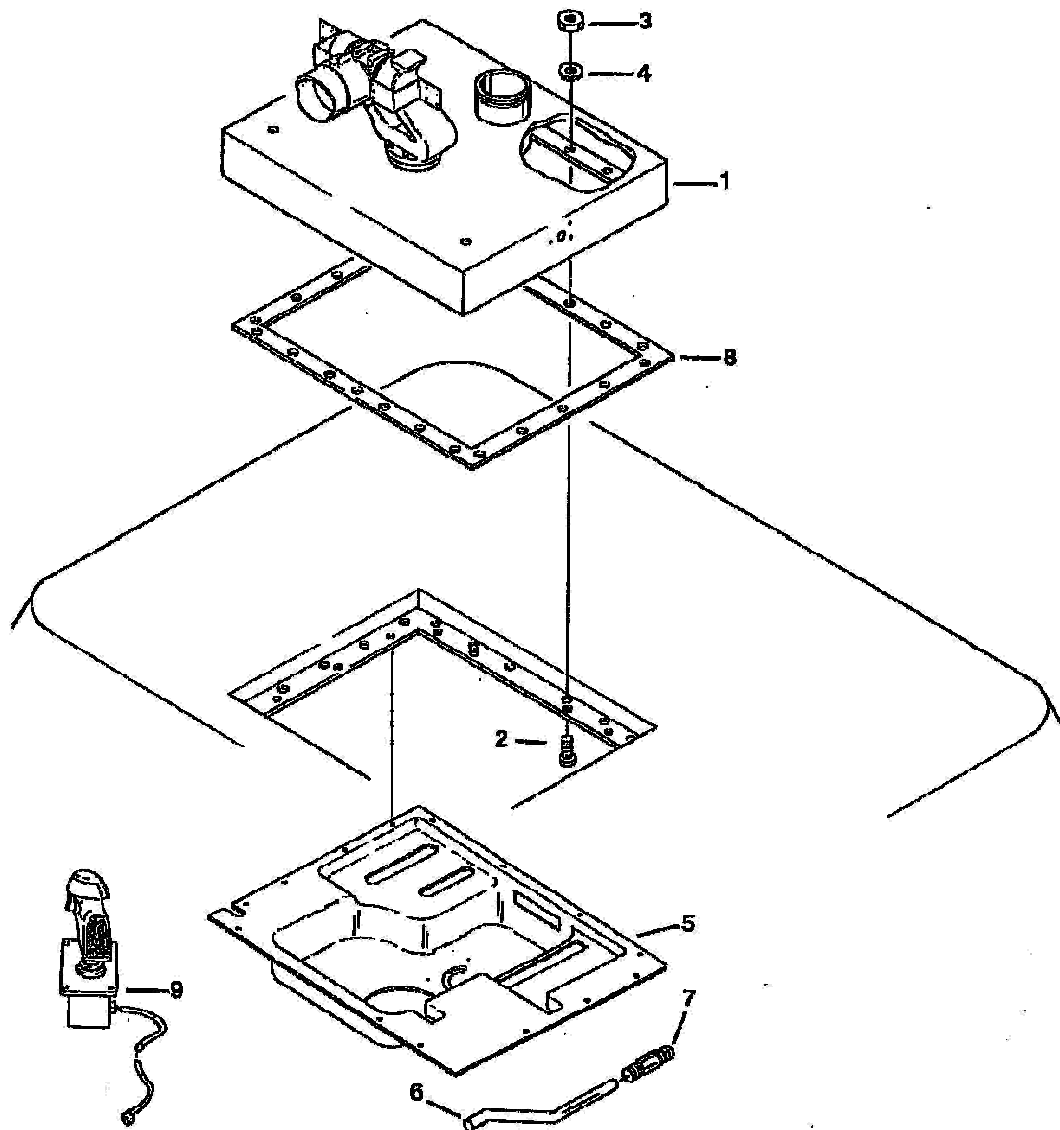

- 1. Roof Turret Assembly
- 2. Screw
- 3. Nut
- 4. Washer

- 5. Ceiling
- 6. Handle
- 7. Grip
- 8. Gasket

- 9. Joystick

Figure 2-2 Roof Turret Installation.

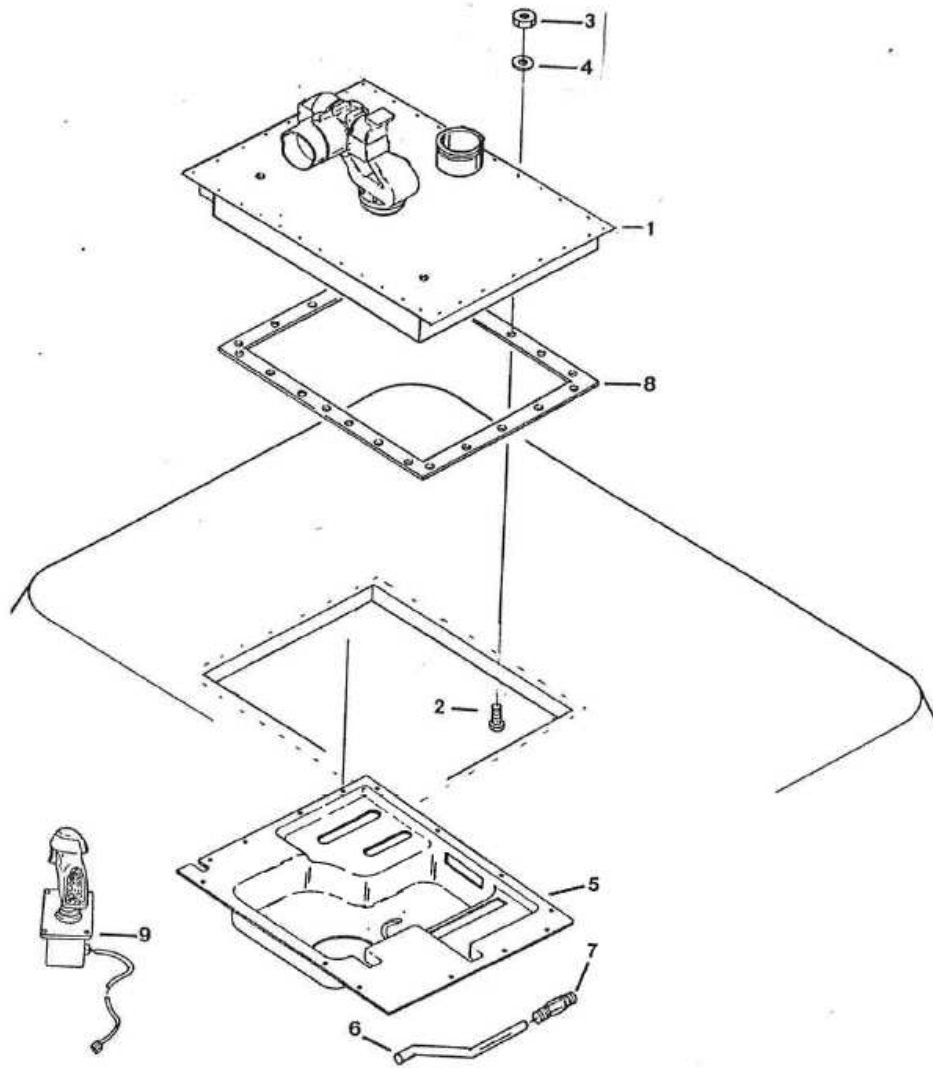

- 1. ROOF TURRET ASSEMBLY
- 2. SCREW
- 3. NUT

- 4. WASHER
- 5. CEILING
- 6. HANDLE

- 7. GRIP
- 8. GASKET
- 9. JOYSTICK

Figure 2-2. Roof Turret Installation.

TYPE 2 TURRET VIEW

WARNING

To avoid injury, keep personnel clear of area below turret during removal.

- (3) Remove two spot lights and air horn assemblies and set aside. b.

Cleaning and inspection.

Clean and inspect in accordance with paragraph 2- 10.

- c. Installation. Refer to Figure 2-2 unless otherwise indicated.

- (1) Install spot lights and air horn assemblies on turret.
- (2) Install eyebolts at comers of turret (1).
- (3) install new gasket (8) and hoist turret (1) onto cab.
- (4) Attach turret(1) to cab roof with 22 screws (2). washers (4) and nuts (3). Tighten bolts to 10 lb. ft.(13.6 N-m).
- (5) Attach roof turret agent supply line to turret (1) using seal and coupling.
- (6) Install windshield coolant manifold to cab.
- (7) Connect siren electrical leads.
- (8) Connect air lines to override valve (71, Figure 2-3).
- (9) Connect truck drain hose to drain valve assembly (124).
- (10) Connect power cable and joystick cable to printed circuit board and attach cables to roof turret mounting plate (paragraph 2-33).
- (11) Carefully maneuver the false ceiling (5, Figure 2-2) over turret controls and align with 2-14 attaching holes. Secure in place with four-teen 1/4 turn studs.
- (12) Restore system air pressure and check operation of roof turret.

2-14. ROOF TURRET REPAIR

Refer to Figure 2-3. The location of the roof turret major subassemblies and parts are illustrated along with their associated attaching hardware. The subassemblies are further broken down and illustrated in the figures following Figure 2-3.

WARNING

Mechanisms in this turret can cause injury to personnel. Keep fingers, hands and tools clear of any moving parts when working on the turret. When working inside the turret, turn off any and all power (air and electric) supplies.

CAUTION

Before restoring power to the turret, be sure that no wire ends or connectors are touching the cylinders, panel, or other sources of a possible short Damage to the turret could result.

2-15. ROOF TURRET NOZZLE ASSEMBLY REPAIR.

- a. Removal. Refer to Figure 2-3 unless otherwise indicated.

- (1) Remove screw (2) from baffle head (1) and remove baffle head. Save any shims that may have been used between the baffle head (1) and baffle stem (17).

(2) Remove two screws (4) from cable clamp (3) and remove cable clamp.

(3) Remove pattern control cable (29) from outlet tee (12).

(4) Remove stop screw (6) from pattern sleeve (5) and slide pattern sleeve off outlet tee. Unscrew pattern sleeve from pattern cable.

(5) Remove spring pin (7) connecting elevation clevis (8) to elevation shaft (43).

(6) Remove two spring pins (10) and pins (11) connecting elevation clevis (8) to upper elevation links (9) and remove elevation clevis.

TYPE 1 TURRET VIEW

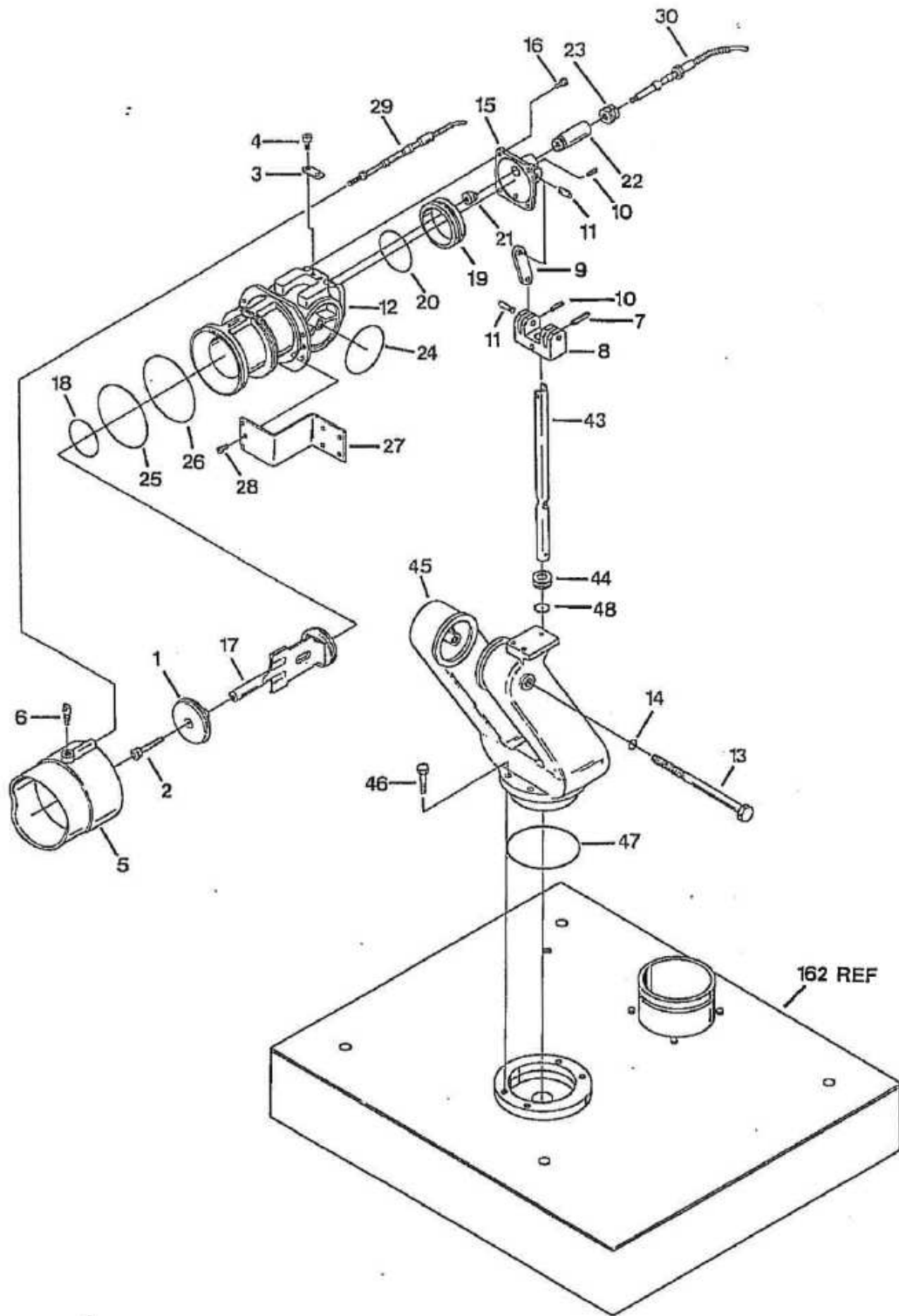

Figure 2-3. Roof Turret Assembly (Sheet 1).

TYPE 1 TURRET VIEW

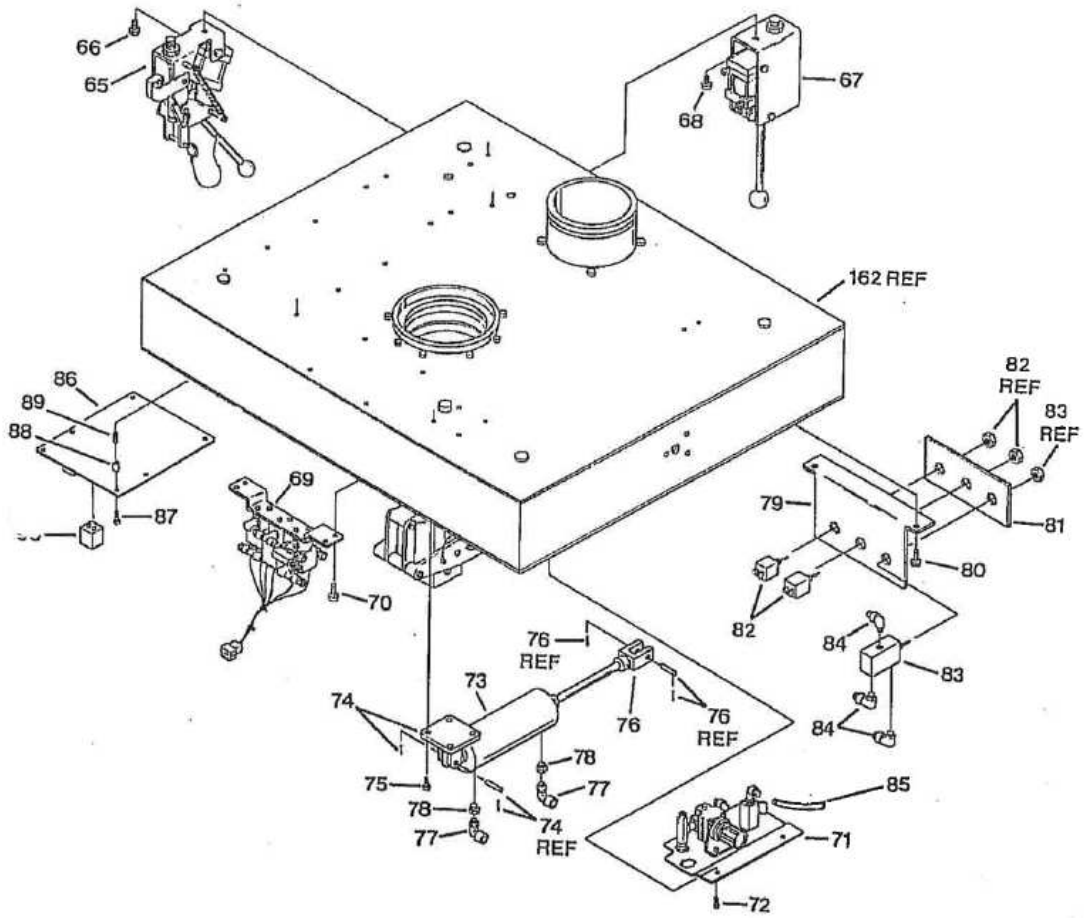

Figure 2-3. Roof Turret Assembly (Sheet 2).

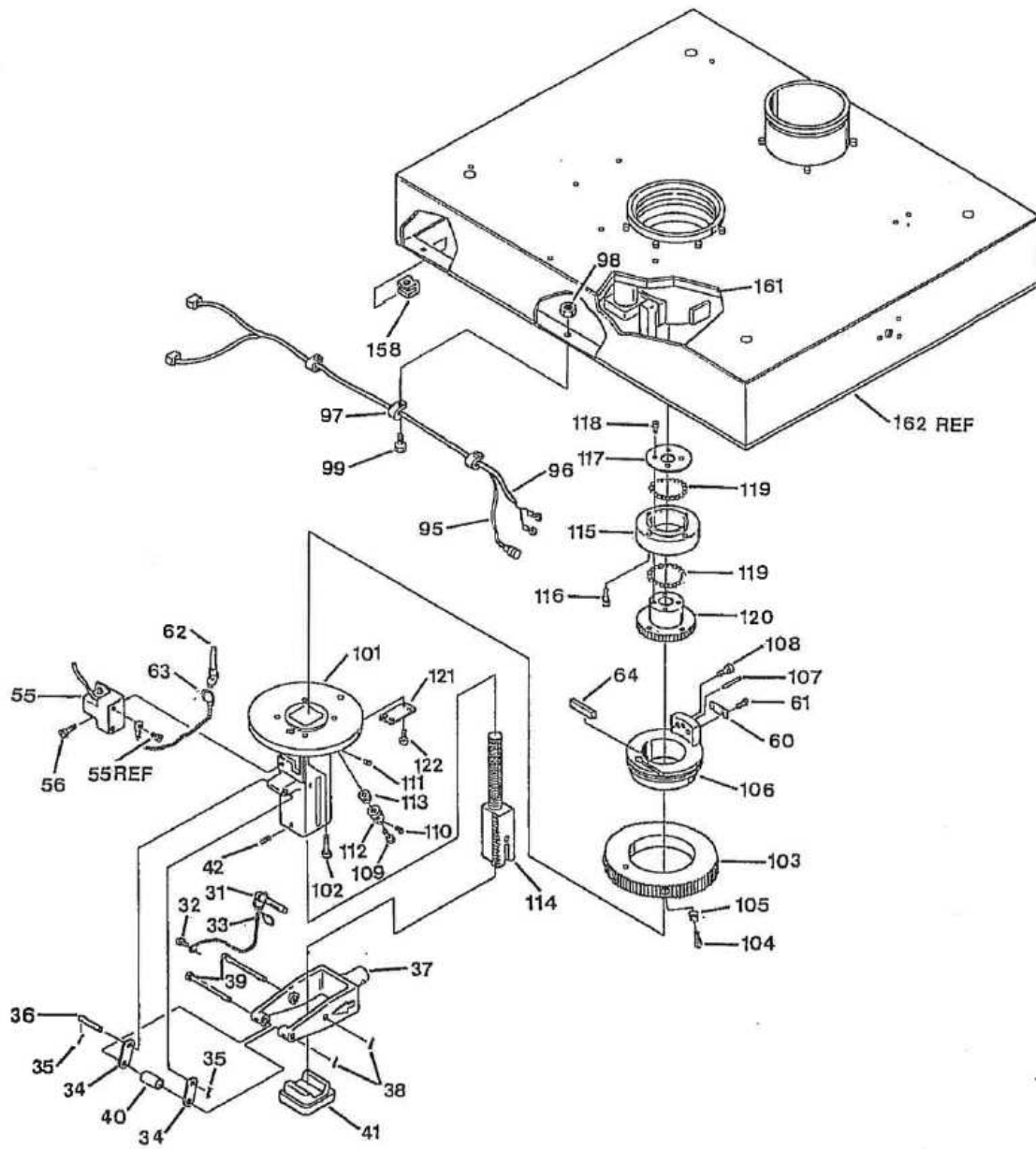

Figure 2-3. Roof Turret Assembly (Sheet 3).

TYPE 1 TURRET VIEW

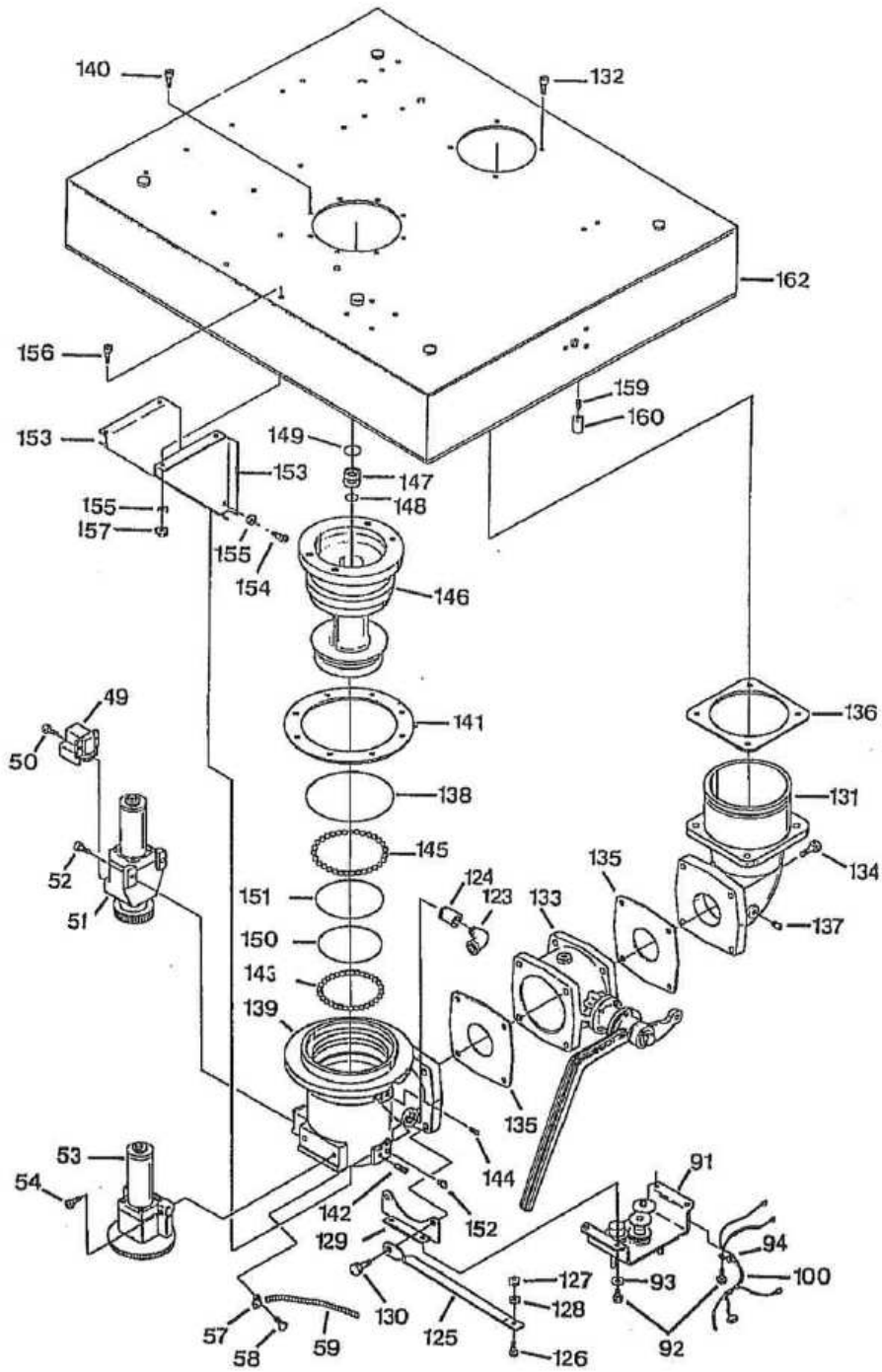

Figure 2-3. Roof Turret Assembly (Sheet 4).

TYPE 1 TURRET VIEW

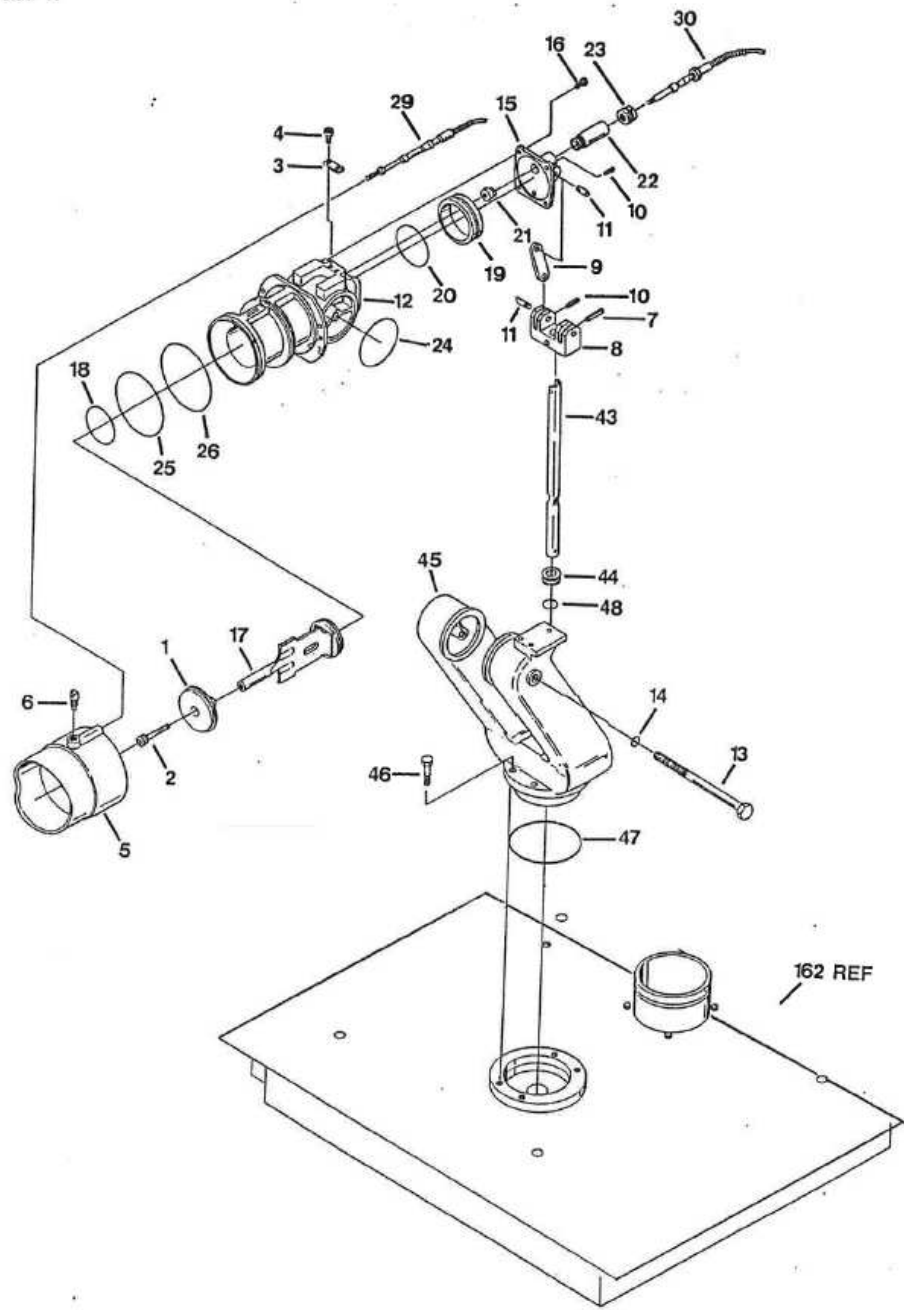

Figure 2-3. Roof Turret Assembly (Sheet 1).

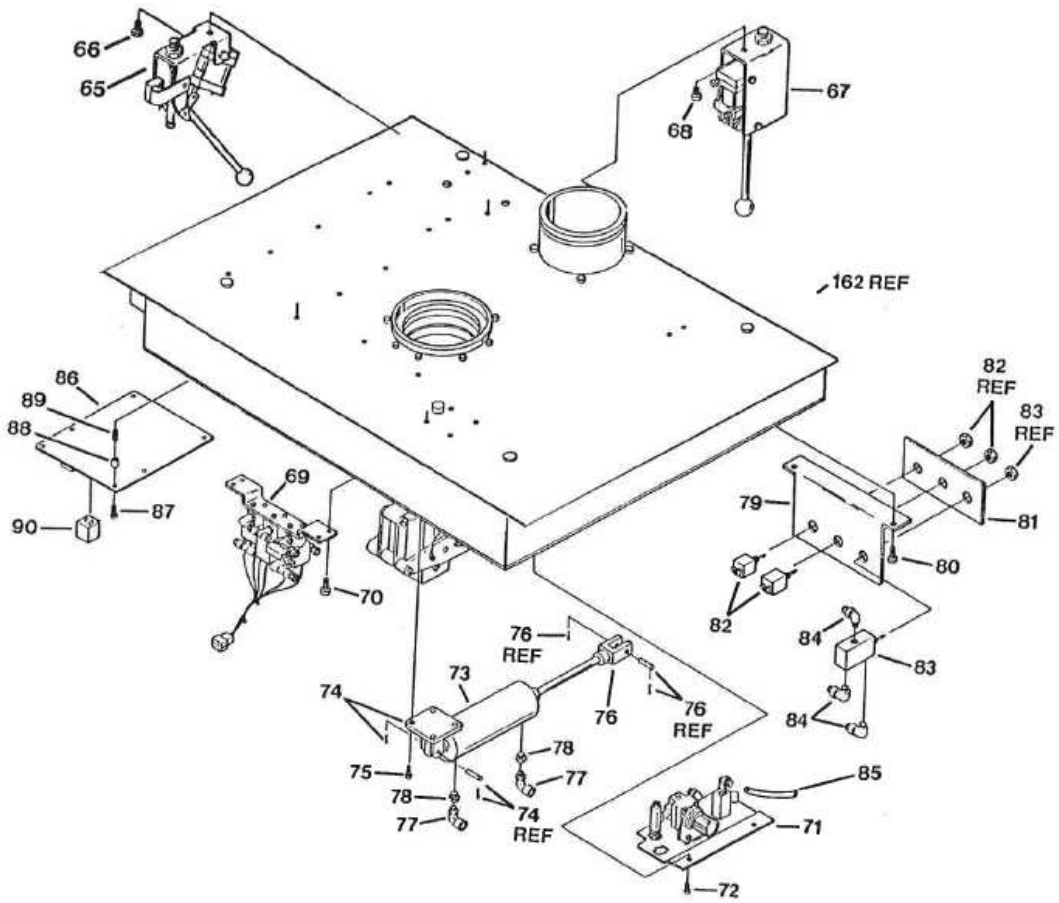

Figure 2-3. Roof Turret Assembly (Sheet 2).

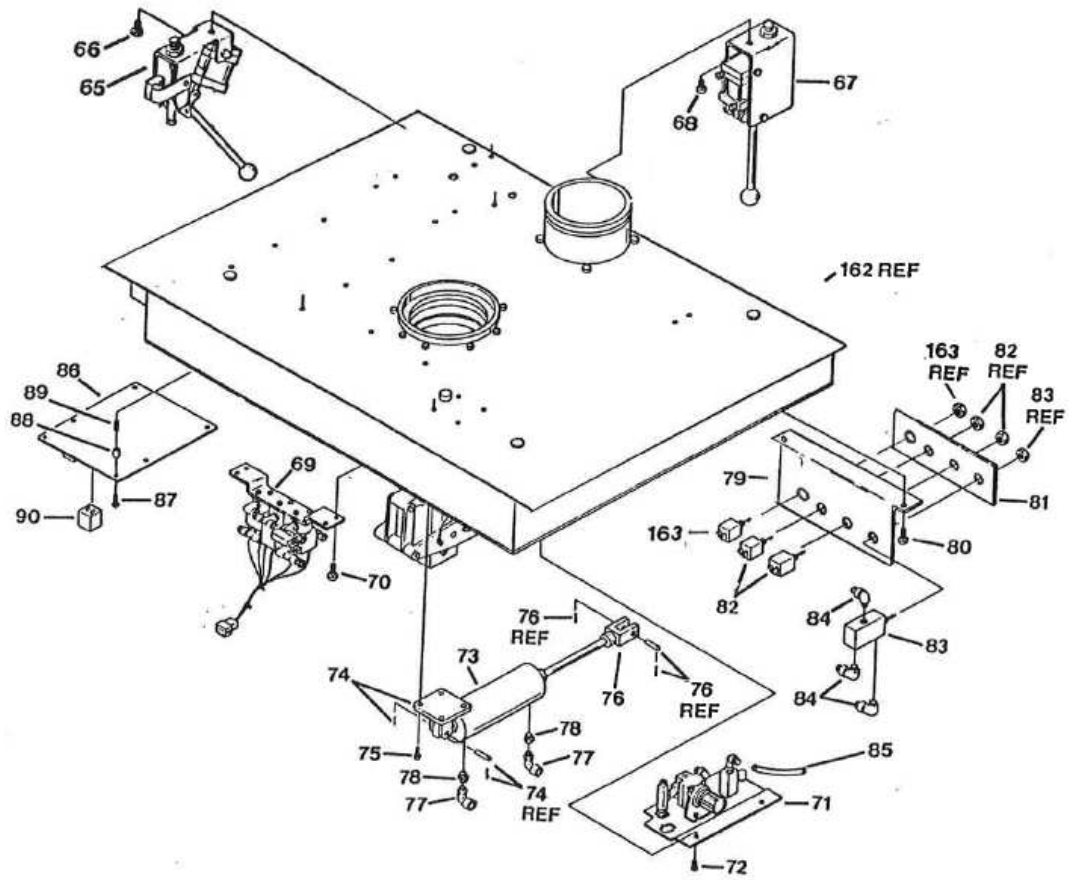

Figure 2-3. Roof Turret Assembly (Sheet 2).

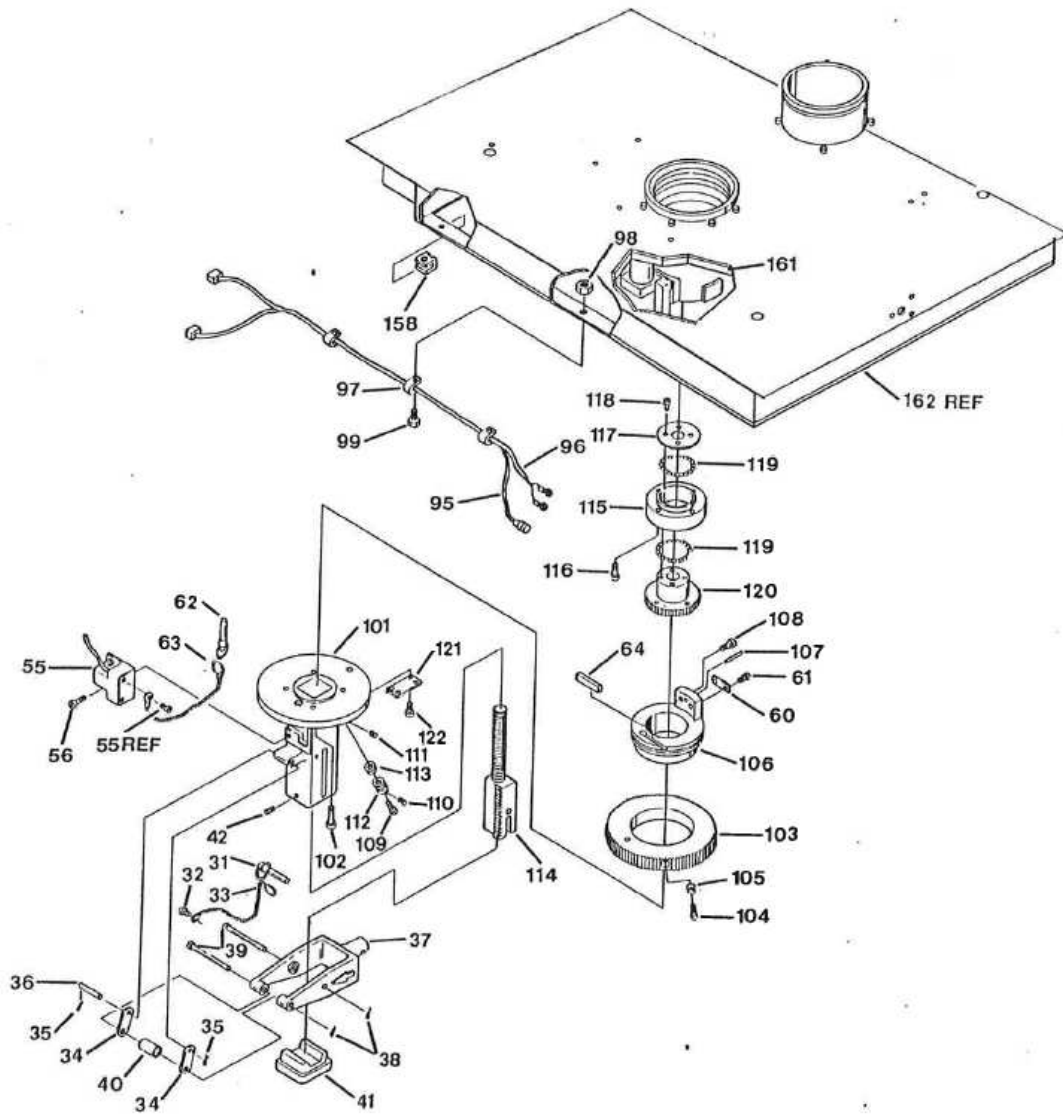

Figure 2-3. Roof Turret Assembly (Sheet 3).

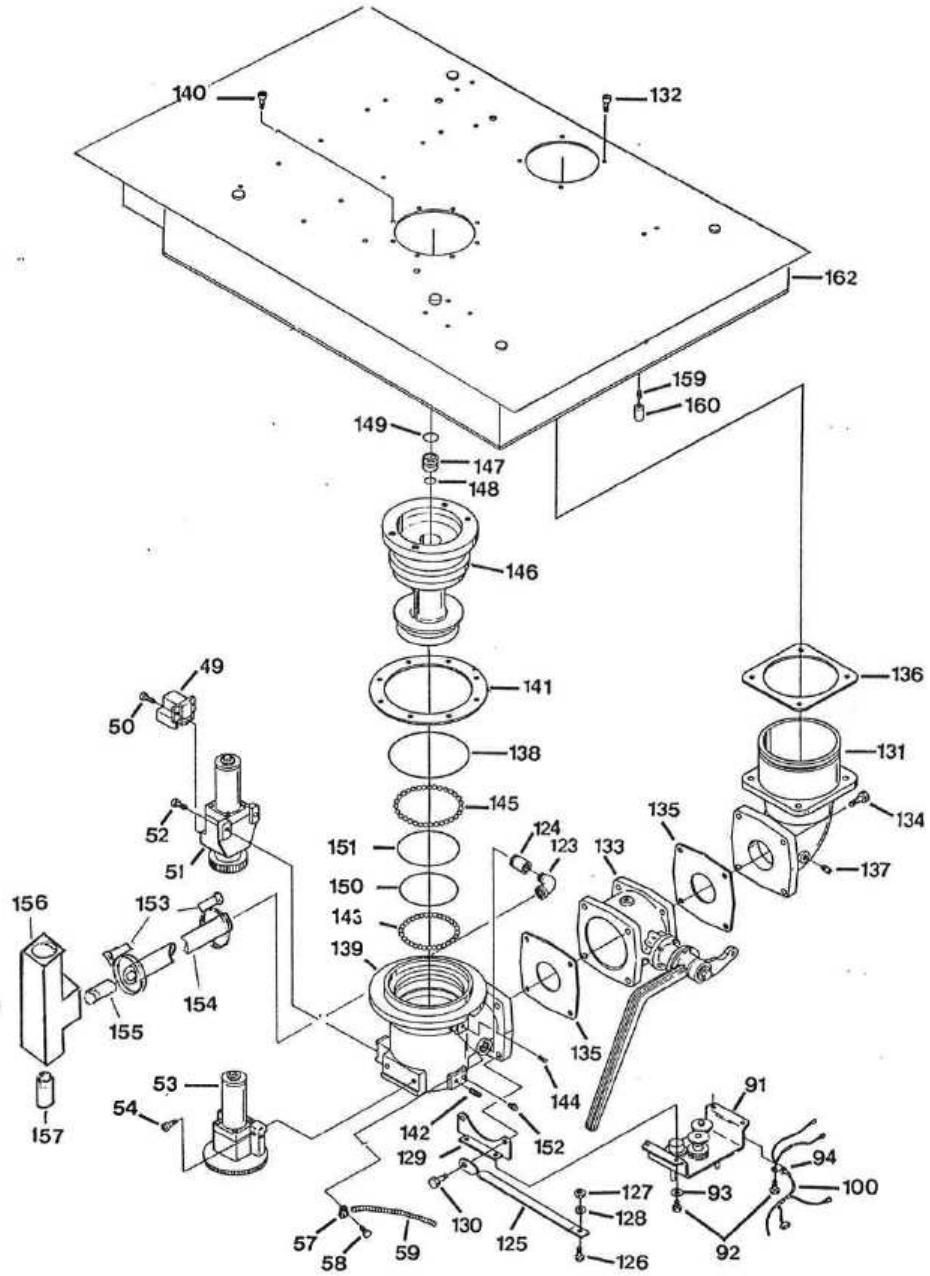

Figure 2-3. Roof Turret Assembly (Sheet 4).

- | | | |
|--------------------------------|--|--------------------------------|
| 1. Baffle Head | 55. Elevation Feedback Assembly | 110. Screw |
| 2. Screw | 56. Screw | 111. Screw |
| 3. Clamp | 57. Clamp | 112. Nut |
| 4. Screw | 58. Screw | 113. Washer |
| 5. Pattern Sleeve | 59. Wrap Clamp | 114. Elevation Screw |
| 6. Screw | 60. Screw | 115. Adapter |
| 7. Pin | 61. Pin | 116. Screw |
| 8. Clevis | 62. Pin | 117. Plate |
| 9. Upper Link | 63. Chain | 118. Screw |
| 10. Pin | 64. Cover | 119. Bearing |
| 11. Pin | 65. Rate Control Assembly | 120. Gear Nut |
| 12. Tee | 66. Screw | 121. ID Plate |
| 13. Bolt | 67. Pattern Control Assembly | 122. Nail |
| 14. O-Ring | 68. Screw | 123. Elbow |
| 15. Bracket | 69. Solenoid Valve Assembly | 124. Drain Valve Assembly |
| 16. Screw | 70. Screw | 125. Strap |
| 17. Baffle Stem | 71. Override Valve Assembly | 126. Screw |
| 18. O-Ring | 72. Screw | 127. Nut |
| 19. Bushing | 73. Air Cylinder | 128. Washer |
| 20. O-Ring | 74. Bracket with Pin and Cotter Pin | 129. Bracket |
| 21. Nut | 75. Screw | 130. Screw |
| 22. Tube | 76. Clevis | 131. Victaulic Inlet |
| 23. Nut | 77. Elbow | 132. Screw |
| 24. O-Ring | 78. Adapter | 133. Three Inch Valve Assembly |
| 25. O-Ring | 79. Switch Bracket | 134. Screw |
| 26. O-Ring | 80. Screw | 135. Gasket |
| 27. Bracket | 81. Label | 136. Gasket |
| 28. Screw | 82. Switch | 137. Plug |
| 29. Pattern Cable | 83. Valve | 138. O-Ring |
| 30. Rate Cable | 84. Elbow | 139. Inlet Elbow |
| 31. Pin | 85. Air Hose | 140. Screw |
| 32. Screw | 86. Circuit Board | 141. Gasket |
| 33. Chain | 87. Screw | 142. Plug |
| 34. Link | 88. Standoff | 143. Ball Bearing |
| 35. Pin | 89. Screw | 144. Plug |
| 36. Pin | 90. Relay | 145. Ball Bearing |
| 37. Bracket | 91. Oscillation Limit Control Assembly | 146. Siamese Base |
| 38. Pin | 92. Screw | 147. Bushing |
| 39. Pin | 93. Washer | 148. O-Ring |
| 40. Spacer | 94. Clamp | 149. O-Ring |
| 41. Bumper | 95. Wiring Harness | 150. O-Ring |
| 42. Pin | 96. Power Cable | 151. O-Ring |
| 43. Shaft | 97. Clamp | 152. Fitting |
| 44. Spring Washer | 98. Nut | 153. Bracket |
| 45. Siamese | 99. Screw | 154. Screw |
| 46. Screw | 100. Wiring Harness | 155. Washer |
| 47. O-Ring | 101. Yoke | 156. Screw |
| 48. O-Ring | 102. Screw | 157. Nut |
| 49. Rotation Feedback Assembly | 103. Gear | 158. Clip |
| 50. Screw | 104. Screw | 159. Screw |
| 51. Rotation Gearbox Assembly | 105. Stop | 160. Standoff |
| 52. Screw | 106. Adapter Housing | 161. Insulation |
| 53. Elevation Gearbox Assembly | 107. Pin | 162. Plate |
| 54. Screw | 108. Screw | 163. Switch |
| | 109. Screw | |

Figure 2-3a Roof Turret Assembly

* With Dry Chemical Nozzle

- | | | |
|--------------------------------|--|--------------------------------|
| 1. Baffle Head | 55. Elevation Feedback Assembly | 109. Screw |
| 2. Screw | 56. Screw | 110. Screw |
| 3. Clamp | 57. Clamp | 111. Screw |
| 4. Screw | 58. Screw | 112. Nut |
| 5. Pattern Sleeve | 59. Wrap Clamp | 113. Washer |
| 6. Screw | 60. Screw | 114. Elevation Screw |
| 7. Pin | 61. Pin | 115. Adapter |
| 8. Clevis | 62. Pin | 116. Screw |
| 9. Upper Link | 63. Chain | 117. Plate |
| 10. Pin | 64. Cover | 118. Screw |
| 11. Pin | 65. Rate Control Assembly | 119. Bearing |
| 12. Tee | 66. Screw | 120. Gear Nut |
| 13. Bolt | 67. Pattern Control Assembly | 121. ID Plate |
| 14. O-Ring | 68. Screw | 122. Nail |
| 15. Bracket | 69. Solenoid Valve Assembly | 123. Elbow |
| 16. Screw | 70. Screw | 124. Drain Valve Assembly |
| 17. Baffle Stem | 71. Override Valve Assembly | 125. Strap |
| 18. O-Ring | 72. Screw | 126. Screw |
| 19. Bushing | 73. Air Cylinder | 127. Nut |
| 20. O-Ring | 74. Bracket with Pin and Cotter Pin | 128. Washer |
| 21. Nut | 75. Screw | 129. Bracket |
| 22. Tube | 76. Clevis | 130. Screw |
| 23. Nut | 77. Elbow | 131. Victaulic Inlet |
| 24. O-Ring | 78. Adapter | 132. Screw |
| 25. O-Ring | 79. Switch Bracket | 133. Three Inch Valve Assembly |
| 26. O-Ring | 80. Screw | 134. Screw |
| 27. Bracket | 81. Label | 135. Gasket |
| 28. Screw | 82. Switch | 136. Gasket |
| 29. Pattern Cable | 83. Valve | 137. Plug |
| 30. Rate Cable | 84. Elbow | 138. O-Ring |
| 31. Pin | 85. Air Hose | 139. Inlet Elbow |
| 32. Screw | 86. Circuit Board | 140. Screw |
| 33. Chain | 87. Screw | 141. Gasket |
| 34. Link | 88. Standoff | 142. Plug |
| 35. Pin | 89. Screw | 143. Ball Bearing |
| 36. Pin | 90. Relay | 144. Plug |
| 37. Bracket | 91. Oscillation Limit Control Assembly | 145. Ball Bearing |
| 38. Pin | 92. Screw | 146. Siamese Base |
| 39. Pin | 93. Washer | 147. Bushing |
| 40. Spacer | 94. Clamp | 148. O-Ring |
| 41. Bumper | 95. Wiring Harness | 149. O-Ring |
| 42. Pin | 96. Power Cable | 150. O-Ring |
| 43. Shaft | 97. Clamp | 151. O-Ring |
| 44. Spring Washer | 98. Nut | 152. Fitting |
| 45. Siamese | 99. Screw | 153. Bracket |
| 46. Screw | 100. Wiring Harness | 154. Screw |
| 47. O-Ring | 101. Yoke | 155. Washer |
| 48. O-Ring | 102. Screw | 156. Screw |
| 49. Rotation Feedback Assembly | 103. Gear | 157. Nut |
| 50. Screw | 104. Screw | 158. Clip |
| 51. Rotation Gearbox Assembly | 105. Stop | 159. Screw |
| 52. Screw | 106. Adapter Housing | 160. Standoff |
| 53. Elevation Gearbox Assembly | 107. Pin | 161. Insulation |
| 54. Screw | 108. Screw | 162. Plate |

Figure 2-3a Roof Turret Assembly

* Without Dry Chemical Nozzle

- (7) Remove bolt (13) and O-ring (14) attaching outlet tee (12) to the Siamese (45).
- (8) Remove four screws (16) attaching cable bracket (15) to the back of the outlet tee and pull assembled parts out of outlet tee.
- (9) Screw the baffle stem (17) off the rate cable
- (10) Remove two spring pins (10) and pins (11) connecting elevation links (9) to cable bracket (15) and remove two elevation links.
- (11) Remove the baffle stem bushing (19) from baffle stem (17).

b. Disassembly Refer to Figure 2-3.

- (1) Remove O-rings (24,25, and 26) from outlet tee (12), O-ring (18) from baffle stem (17), and O-ring (20) from baffle stem bushing (19).
- (2) If required, unscrew the cable nut (21), cable bracket(15),cable end tube (22), and adapter nut (23) from the end of the rate cable (30).
- (3) If required, remove screws (28) mounting spotlight brackets (27) to outlet tee (12).

c. Cleaning and Inspection. Clean and inspect all parts in accordance with paragraph 2-10.

d. Assembly. Refer to Figure 2-3 unless otherwise indicated.

- (1) Apply lubricant (1, Appendix A) to O-rings (18,20,24,25and 26). Install O-ring (18) on baffle stem (17), O-ring (20) on baffle stem bushing (19), and O-rings (24,25 and 26) on outlet tee (12).
- (2) Attach the upper elevation links (9) to cable bracket (15) with pins (11) and spring pins
- (3) Apply Loctite (2, Appendix A) to threads of cable tube (22). Screw cable tube onto the adapter nut.
- (4) Position nut at end of rate cable (30) 3/8" from end of thread as shown in Figure 2-4.
- (5) Screw adapter nut (23) onto end of rate cable (30) until it contacts nut attached to rate cable.
- (6) Screw cable nut (21) onto end of rate cable until 3/8" of rate cable projects from nut as shown in Figure 2-4.

e. Installation Refer to Figure 2-3.

- (1) Apply lubricant (1, Appendix A) to the bore of baffle stem bushing (19) and place onto baffle stem (17).
- (2) Screw the baffle stem (17) onto 3/8"projecting rate cable (30) and tighten cable nut (21).
- (3) Insert the baffle stem into the outlet tee (1 2).
- (4) Attach the cable bracket to the back of the outlet tee with screws (16) and tighten.
- (5) Lubricate (1, Appendix A) the O-ring surfaces on the Siamese and slide the outlet tee into the Siamese being careful not to pinch O-rings.
- (6) Install O-ring (14) onto bolt (13). After O-ring is positioned against the bolt head, apply lubricant (1, Appendix A) to O-ring. Apply Loctite (3, Appendix A) to threads of bolt head. Insert the bolt through the Siamese and through the outlet tee. While tightening the bolt, oscillate the outlet tee vertically through an approximate 45degreesarc. Continue to tighten the bolt slowly until an increase in drag is felt on the outlet tee. Back the screw out slightly until the increase drag disappears.

- (7) Attach elevation clevis (8) to upper elevation links (9) with pins (11) and spring pins (10).
- (8) Attach elevation clevis (8) to elevation shaft (43) with spring pin (7).
- (9) On pattern cable (29), position nut 1/4" from end of thread as shown in Figure 2-4. Screw pattern sleeve (5) onto pattern cable. Slide pattern sleeve (5) onto the outlet tee (12). Apply Loctite (2, Appendix A) to threads of screw (6). Attach pattern sleeve to outlet tee with screw and tighten.
- (10) Apply Loctite (2, Appendix A) to threads of screws (4). Secure pattern control cable in place using cable clamp (3) and screws (4). Tighten screws until pattern control cable is securely held in place, but cable clamp is not deformed.
- (11) install baffle head (1) into outlet tee with screw (2) and any shims removed during disassembly. If shims are lost, measure length of the baffle head (1). Total length of baffle head should be 1.565 inches. If baffle head measures less than 1.565 inches, add shims to achieve ideal length.
- (12) Attach spotlight brackets (27) to outlet tee with screws (28).

f. Cable Adjustment Refer to paragraph 2-17 to verify and adjust alignment of the pattern and rate cables.

2-16. FALSE CEILING REPLACEMENT

a. Removal. Refer to Figure 2-5 unless otherwise indicated.

- (1) Locate turret indicator at straight ahead and fully elevated position.
 - (2) Remove manual turret control handle (6, Figure 2-2) if installed.
 - (3) Place operating mode switch in MANUAL position.
 - (4) Place manual rate and pattern control levers in LOW AATE and SOLID STREAM positions.
 - (5) Rotate fourteen studs (2) ¼ turn counter-clockwise. Remove false ceiling (1) by working it around the lever controls of turret.
 - (6) If replacing spring clip (5), remove screw (6), nut (7), and washer (8) attaching clip to false ceiling (1).
 - (7) If replacing stud retainer (3), remove from false ceiling (1).
 - (8) Replace any nameplates that are not legible. Nameplate (9) is secured with rivets (10) and washers (11). Nameplates (12 through 17) are secured with rivets (18) and washers (19).
- I. Cleaning and inspection. Clean and inspect all parts in accordance with paragraph 2-10.

Installation. Refer to Figure 2-5.

- (1) install nameplates (12 through 17) if re-moved, using rivets (18) and washers (19).
- (2) Install nameplate (9) if removed, using rivets (10) and washers (11).
- (3) Install stud retainer (3) over mounting holes. Install clip (5) if removed, with screw (6), nut (7) and washer (8).

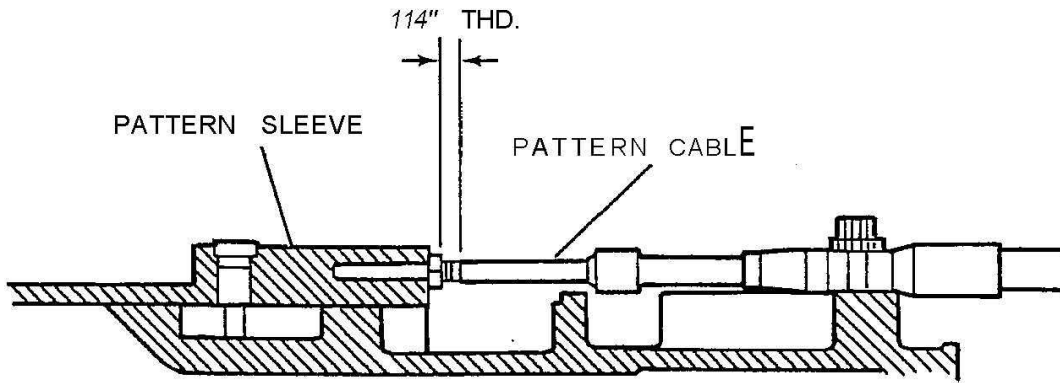

PATTERN CABLE ADJUSTMENT

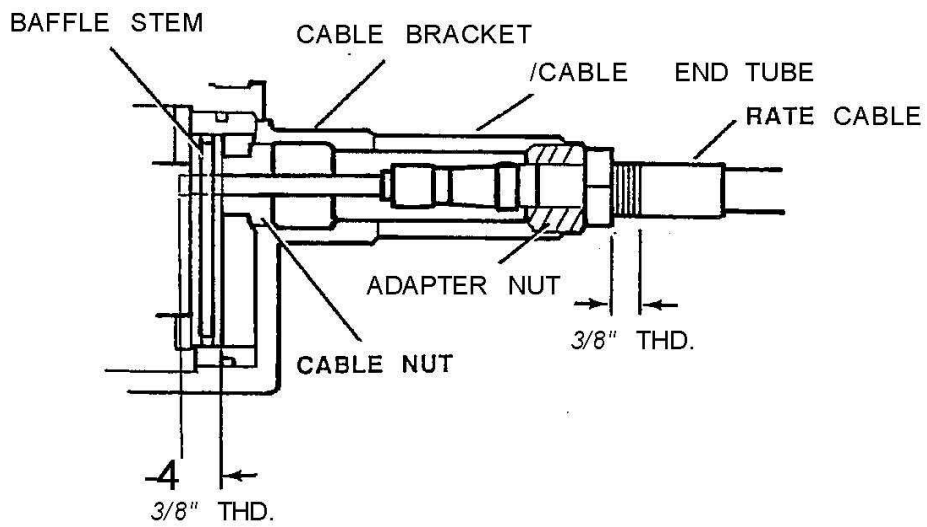

RATE CABLE ADJUSTMENT

Figure 2-4. Pattern and Rate Cable Adjustments.

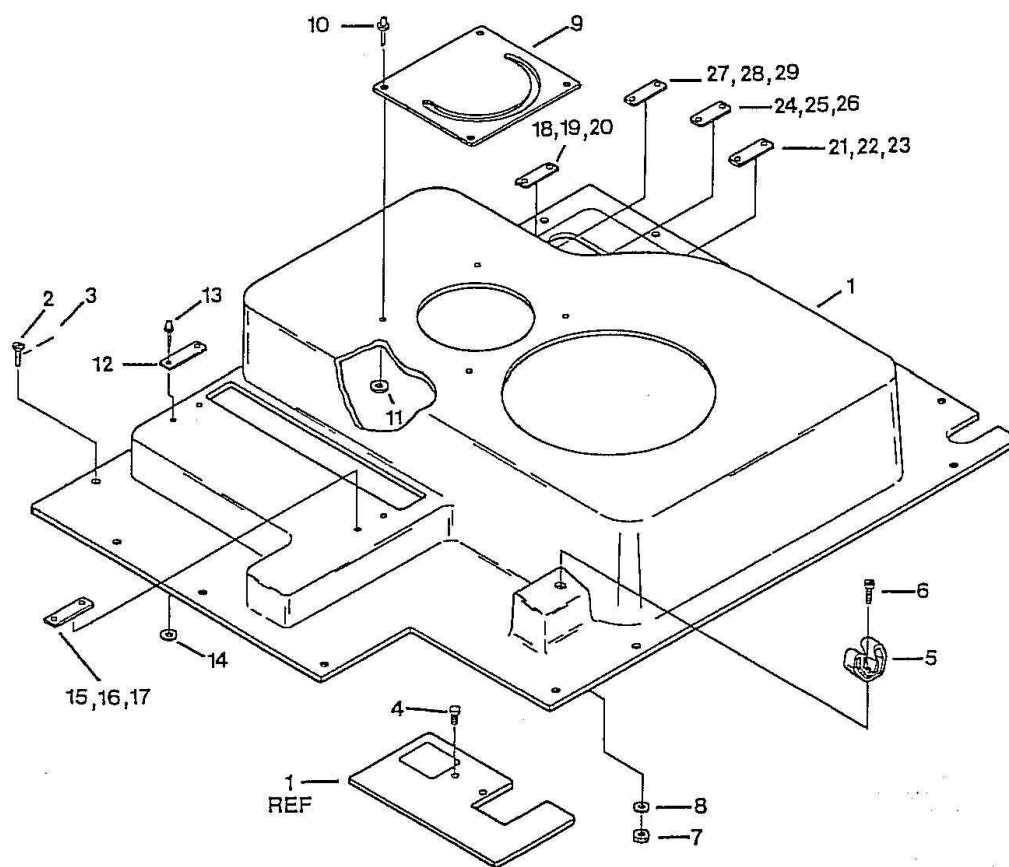

- | | |
|-------------|------------------------|
| 1. Screw | 11. Washer |
| 2. Stud | 12. Valve Open Label |
| 3. Retainer | 13. Valve Closed Label |
| 4. Screw | 14. Low Flow Label |
| 5. Clip | 15. High Flow Label |
| 6. Screw | 16. Dispersed Label |
| 7. Nut | 17. Solid Stream Label |
| 8. Washer | 18. Rivet |
| 9. Cover | 19. Washer |
| 10. Rivet | |

Figure 2-5 False Ceiling Replacement

(4) Carefully maneuver the false ceiling (1) over turret controls and a line with attaching holes.

(5) Secure false ceiling (1) with fourteen 1/4 turn studs (2).

2-17. PATTERN AND RATE CABLE REPLACEMENT.

a. Removal. Refer to Figure 2-3 unless otherwise indicated.

NOTE

Steps (1) through (4) are common to both the pattern and rate cables.

(1) Place operating mode switch to MANUAL.

(2) Remove false ceiling (see paragraph 2-16).

(3) If replacing rate cable (30, Figure 2-3), push manual rate control to the HIGH FLOW position.

(4) If replacing pattern cable (29, Figure 2-3), push manual pattern control to DISPERSED pattern position.

(5) Complete pattern cable removal as follows:

(a) Remove cotter pin (7, Figure 2-12) and pin (6) attaching cable fitting(8) to handle hub (3).

(b) Remove cable fitting(8) from pat-tern cable.

(c) Remove pattern cable mounting nut on inside of roof turret mounting plate. Grasp pattern cable from outside of roof turret housing and pull cable out of housing.

(d) Remove screws (4, Figure 2-3) and cable clamp (3) from top of nozzle.

(e) Remove screw (6) and pattern sleeve (5). Unscrew tip of pattern cable from back of pattern sleeve.

(6) Complete rate cable removal as follows:

(a) Remove nozzle assembly following procedures in paragraph 2-15.

(b) Remove cotter pin (6, Figure 2-1 1) and pin (7) attaching spring housing (5) to handle hub (22).

(c) Unscrew spring housing from rate cable.

(d) Remove rate cable mounting nut on inside of roof turret mounting plate. Grasp rate cable from outside of roof turret housing and pull cable out of housing.

b. Cleaning and Inspection. Clean and inspect all parts in accordance with paragraph 2-10

c. Installation. Refer to Figure 2-3 unless otherwise indicated.

NOTE

If both the pattern and rate cables have been removed, reinstall the rate cable first.

(1) Rate Cable. Refer to Figure 2-3 unless otherwise indicated.

(a) Perform rate cable installation at roof turret nozzle following procedures in paragraph 2-15.d and 2- 15.e.

(b) Remove one mounting nut and lock washer from rate control cable (30). Feed the cable through the turret mounting plate. Replace the lock washer and mounting nut on the loose end of the rate cable from the Inside of the turret mounting plate.

(c) Screw spring housing (5, Figure 2- 11) onto rate cable until threaded portion of rate cable is flush with tip of spring nut (9).

(d) Attach spring housing (5) to handle hub (22) with pin (7). Do not install cotter pin (6) until after alignment on rate cable is complete.

(2) Pattern Cable. Refer to Figure 2-3 unless otherwise indicated.

(a) At nozzle end of pattern cable (29), position nut 1/4" from end of thread as shown in Figure 2-4.

(b) Screw tip of pattern control cable into back of pattern sleeve (5). In-stall pattern sleeve onto outlet tee (12) with screw (6).

(c) Apply Loctite (2, Appendix A) to threads of screws (4). Secure pattern control cable in place using cable clamp (3) and screws (4). Tighten screws until pattern control cable is securely held in place, but cable clamp is not deformed.

(d) Remove one mounting nut and lock washer from pattern cable. Feed the cable through the turret mounting plate. Replace the lock washer and mounting nut on the loose end of the pattern cable from the inside of the turret mounting plate.

(e) Attach cable fitting (8, Figure 2-1 2) to loose end of pattern cable. (1)

(f) Attach cable fitting to handle hub (3) with pin (6). Do not install cotter pin (7) until after alignment of pattern cable is complete.

d. Adjustment.

(1) Rate Cable. Refer to Figure 2-11 unless otherwise indicated.

(a) Point roof turret nozzle straight ahead.

(b) Using spring scale on end of rate control handle, measure force required to move handle over center to low rate position.

(c) Adjust rate cable as follows:

1 If tension is less than 6.2 lbs. tighten spring housing (rotate clockwise) onto cable in one turn increments until tension is in the 6.6 lb to 7.2 lb range.

2 If tension is 6.2 to 6.4 lbs. tighten spring housing (rotate clockwise) onto cable in 112 turn increments until tension is in the 6.6 lb to 7.2 lb range.

3 If tension is 7.2 lbs or greater, loosen spring housing (rotate counter-clockwise) on cable in 112 turn increments until tension is in the 6.6 to 7.2 lb. range.

(d) Rotate turret handle 90degreesclockwise (as viewed from bottom) and check for over-center condition. If the rate control handle does not lock firmly into the low rate position, tighten the spring housing (rotate clockwise) In 1/2 turn increments until the rate control handle locks.

(e) After proper alignment of the rate cable is complete, install cotter pin (6) in pin (7).

(f) Loosen rate control cable nut on outside surface of roof turret mounting plate. Apply a bead of polyurethane sealer (6, Appendix A). Tighten nut and wipe off excess sealer.

(g) Install false ceiling (paragraph 2- 16).

(2) Pattern Cable. Refer to Figure 2-3 unless otherwise indicated.

(a) On top of roof turret, manually move pattern sleeve (5) back and forth. if properly adjusted, an audible click should be heard at each end of the pattern sleeve operating range as screw (6) hits each end of the stops. if the screw (6) is not hitting the back stop, adjust the cable fitting (8, Figure 2-12) clockwise. If the screw is not hitting the forward stop, adjust the cable fitting counterclockwise.

(b) Adjust the pattern cable by removing pin (6), if installed, and rotating cable fitting in one turn increments and replacing pin. Adjust cable fit-ting until alignment is achieved.

(c) After proper alignment of the pat-tern cable is complete, install cotter pin (7) in pin (6).

(d) Loosen pattern control cable nut on outside surface of roof turret mounting plate. Apply a bead of polyurethane sealer (6, Appendix A). Tighten nut and wipe off excess sealer.

2-18. ELEVATION SHAFT AND HANDLE REPAIR.

a. Removal. Refer to Figure 2-3.

(1) Remove false ceiling (paragraph 2-16).

(2) Remove screw (32) attaching chain (33) and quick release pin (31) to handle bracket (37).

(3) Remove cotter pin (35) and pivot pin (36) attaching elevation links (34) to handle yoke (101).

(4) Remove two spring pins (42) attaching bumper (41) to handle yoke (101).

(5) Remove cotter pins (38) and handle bracket pins (39) from handle bracket (37). Remove handle bracket, elevation links and spacer (40) from handle yoke.

(6) On top of roof turret, remove spring pin (7) connecting elevation shaft (43)to elevation clevis (8).

(7) Remove bolt (13) and O-ring (14) attaching nozzle assembly to Siamese (45). Carefully lift nozzle assembly off Siamese base using care not to stress cables.

(8) Lift elevation shaft from roof turret. Remove three spring washers (44) from elevation shaft.

b. Cleaning and Inspection. Clean and inspect all parts in accordance with paragraph 2-10.

c. installation. Refer to Figure 2-3.

(1) Slide three spring washers (44) over elevation shaft (43).

(2) Insert the elevation shaft through the hole in the center of the Siamese. The elevation shaft must be inserted so the end with two holes will be inside the truck cab. The flat surface on the second hole must face the driver's side of the cab.

(3) Lubricate (1, Appendix A) the O-ring surfaces on the Siamese and slide the outlet tee into the Siamese being careful not to pinch O-rings.

(4) Install o-ring(14)onto bolt(13). After O-ring is positioned against bolt, apply lubricant (1, Appendix A) to O-ring. Apply Loctite (3, Appendix A) to threads of bolt. Insert the bolt through the Siamese and through the outlet tee. Tighten the bolt until there is a smooth drag of the outlet tee on the Siamese.

(5) Attach elevation clevis (8) to elevation shaft (43) with spring pin (7).

(6) Place handle bracket (37) on elevation shaft. Install handle bracket with spacer (40), elevation links (34) handle bracket pins (39) and cotter pins (38).

(7) Attach elevation links (34) to handle yoke (101) with pivot pin (36) and cotter pin (35).

(8) Apply Loctite (2, Appendix A) to screw (33). Attach quick release pin (31) to handle bracket with chain (33) and screw (32).

(9) Place bumper (41) onto bottom of handle yoke. If required, match drill two 1/8"holes through handle yoke into bumper. Install spring pins (42) into holes.

(10) Install false ceiling (paragraph 2-16).

2-19. SIAMESE REPAIR.

a. Removal. Refer to Figure 2-3.

(1) Remove elevation shaft (paragraph 2-18).

(2) Remove four screws (46) attaching Siamese (45) to the Siamese base (146). Lift the Siamese from the Siamese base.

b. Disassembly.

(1) Remove O-Ring (47) form inside Siamese

(2) Remove O-ring (48) from base of Siamese.

c. Cleaning and Inspection. Clean and inspect all parts in accordance with paragraph 2-1 0.

d. Assembly

(1) Lubricate (1, Appendix A) O-rings (47 and 48). Install O-ring (48) inside Siamese (45). Install O-ring (47) onto base of Siamese.

e. Installation. Refer to Figure 2-3.

(1) Lubricate (1, Appendix A) inside diameter of Siamese base (146).

(2) Place Siamese (45) onto Siamese base so that the Siamese tilts towards the front of the roof turret. Attach Siamese to Siamese base with four bolts (46).

(3) Install elevation shaft (paragraph 2-18).

2-20. ROTATION FEEDBACK ASSEMBLY REPAIR.

a. Removal. Refer to Figure 2-3.

(1) Remove false ceiling (paragraph 2-16).

(2) Disconnect rotation assembly feedback plug from P5 of printed circuit board (86).

(3) Remove two screws (50) attaching rotation feedback assembly (49) to rotation gearbox assembly (51).

(4) Remove rotation feedback assembly from roof turret mounting plate.

b. Disassembly. Refer to Figure 2-6.

(1) Remove screws (2) attaching cover (1) to rotation feedback pot (8). Remove cover.

(2) Remove screw (4) attaching hub (3) to shaft of rotation feedback pot. Remove hub from shaft.

(3) Remove retaining ring (5) from hub.

(4) Remove gear (6) and spring washer(7) from hub

c. Cleaning and inspection.

Clean and inspect all parts in accordance with paragraph 2-1 0.

d. Assembly. Refer to Figure 2-6.

(1) Place spring washer (7) onto hub (3).

NOTE

Place concave side of spring washer against gear.

(2) Place gear (6) on hub over spring washer.

(3) Attach retaining ring (5) on hub. NOTE retaining ring fits into gear recess.

(4) Place hub over shaft of rotation feedback pot (8). Apply Loctite (2, Appendix A) to screw (4) and secure hub in place.

(5) Apply Loctite (2, Appendix A) to screws (2). Attach cover (1)to rotation feedback pot with screws.

e. Installation and Alignment. Refer to Figure 2-3.

(1) Remove mounting screws (104) and horizontal rotation stops (1 05) from rotation gear (1 03).

(2) Remove the rotation manual override pin (62) from mounting hole in handle yoke (101).

(3) Route rotation feedback assembly cable to printed circuit board (86) and connect plug to P5 on printed circuit board.

(4) Move the joystick to the right if the rotation gearbox assembly (51) motor does not energize, proceed to step (6). If the rotation gearbox assembly motor energizes, proceed to step (5).

(5) With the joystick pushed to the right, verify that the rotation gear (103) turns in the counter-clockwise direction. Manually rotate the gear on the rotation feedback assembly counter-clockwise until the rotation gearbox assembly motor de-energizes. This is the right limit of turret rotation. Manually rotate the rotation feedback assembly gear clockwise slightly until the rotation gearbox assembly motor energizes. Release the joystick when the rotation gear is approximately three teeth from the right turret stop. Proceed to step (7).

(6) With the joystick pushed to the left, verify that the rotation gear (1 03) turns in the clockwise direction. Manually rotate the gear on the rotation feedback assembly clockwise until the rotation gearbox assembly motor de-energizes. This is the left limit of turret rotation. Manually rotate the rotation feedback assembly gear

counterclockwise slightly until the rotation gearbox assembly motor energizes. Release the joystick when the rotation gear is approximately three teeth from the left turret stop. Proceed to step (7).

(7) Align teeth of gear on rotation feedback assembly (49) with teeth of gear on rotation gearbox assembly (51). Apply Loctite (2, Appendix A) to two screws (50). Attach rotation feedback assembly to rotation gearbox assembly with screws.

(8) Using the joystick, energize the rotation gear-box assembly motor and rotate the rotation gear (103) until it reaches the opposite stop from step (5) or step (6) above. The rotation gearbox assembly motor will de-energize automatically. Check the clearance between the rotation gearbox assembly (51) gear and the stop is equal to the clearance of the opposite stop. To adjust the clearance, re-move two screws (2, Figure 2-6) and cover (1) from rotation feedback assembly. Using a screwdriver, adjust the hub on the feedback pot (3) and recheck clearances. Apply Loctite (2, Appendix A) to threads of screws (2). Attach cover (1) to rotation feedback assembly with screws (2).

(9) Apply Loctite (2, Appendix A) to threads of screws (104, Figure 2-3). Attach horizontal rotation stops (1 05) to rotation gear (103) with screws.

(10) insert rotation manual override pin (62) into mounting hole in handle yoke (101).

(11) Replace false ceiling (paragraph 2-16).

2-21. ROTATION GEARBOX ASSEMBLY REPAIR. a. Removal. Refer to Figure 2-3.

(1) Remove false ceiling (paragraph 2-16).

(2) Remove rotation feedback assembly (paragraph 2-20).

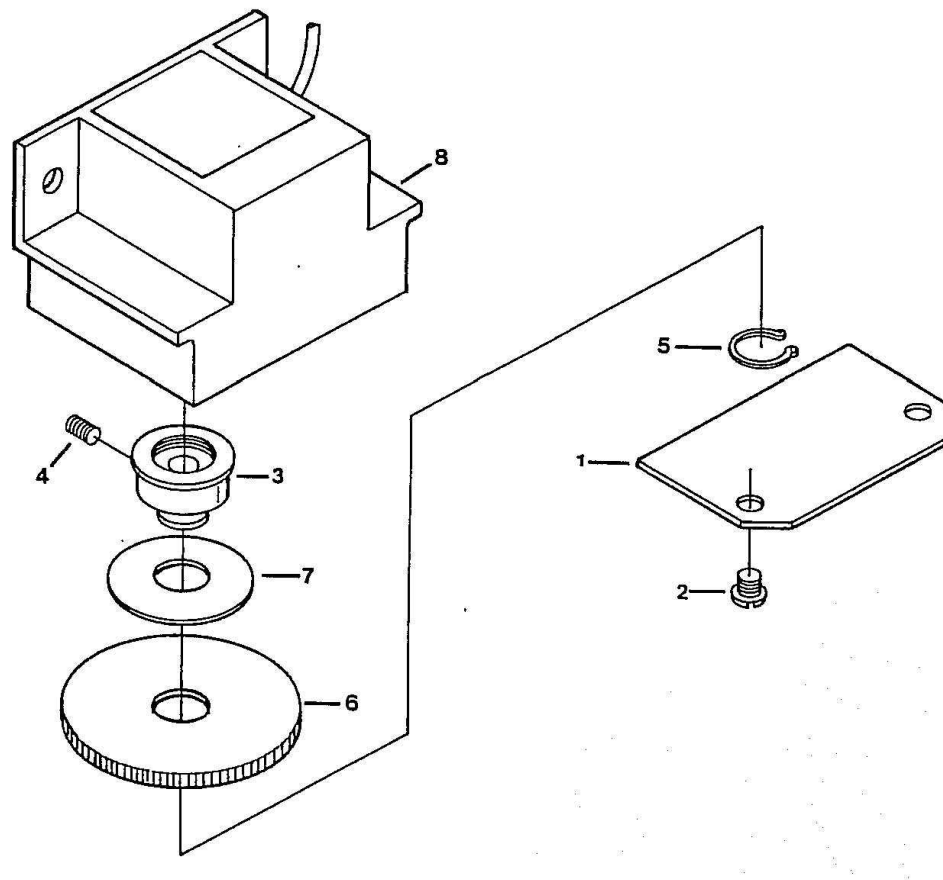

- 4. Screw
- 5. Ring
- 6. Gear

- 7. Washer
- 8. Pot, Subassembly

Figure 2-6 Rotation Feedback Assembly

- (3) Disconnect rotation gearbox assembly plug from P7 of printed circuit board (86).
- (4) Remove two screws (52) attaching rotation gearbox assembly (51) to turret inlet elbow (139).
- (5) Remove rotation gearbox assembly from inside roof turret mounting plate.

b. Disassembly. Refer to Figure 2-7.

- (1) Remove two screws (2) fastening gear (I) to rotation shaft (21). Remove gear and key (3) from rotation shaft.
- (2) Remove four screws (5) attaching motor subassembly to housing (29). Remove motor subassembly from housing.
- (3) Remove four screws (7) attaching adapter plate (4) to motor(6). Remove adapter plate from motor.
- (4) Remove two screws (9) attaching gear (8) to motor. Remove gear from motor.
- (5) If required, disconnect crimp connectors (1 2) from motor and remove crimp connectors from wires (10 and 11). Remove pin connectors (14) from connector housing (13) and remove pin connectors from wire.
- (6) Remove two short carrier plates (15) from housing (29). Remove rivets (17) attaching planetary gears (16) to carrier plate. Re-move planetary gears from carrier plate.
- (7) Remove long carrier plate (18) from housing. Remove rivets (20) attaching planetary gears (19) to carrier plate. Remove planetary gears from carrier plate.
- (8) Remove retaining ring (28) from housing.
- (9) Apply sufficient force to outer race of bearing (22) to remove rotation shaft (21), with as-assembled parts, from housing.
- (10) Remove groove pin (24) attaching rotation carrier (23) to rotation shaft.
- (11) Remove bearing (22) from rotation shaft.
- (12) Remove rivets (26) attaching gears (25) to rotation carrier. Remove gears from rotation carrier.
- (13) Apply sufficient heat to housing to loosen Loctite on internal gear (27). Remove internal gear (27) from housing.

c. Cleaning and inspection. Clean and inspect all parts in accordance with paragraph 2-1 0.

d. Assembly Refer to Figure 2-7.

- (1) Place oil (5, Appendix A) on rivets (17). Peen rivet four gears (16) to both carrier plates (15).
- (2) Place oil (5, Appendix A) on rivets (26). Peen rivet eight gears (25) to rotation carrier (23).
- (3) Place oil (5, Appendix A) on rivets (20). Peen rivet four gears (19) to long carrier plate (18).
- (4) insert rotation shaft (21) into rotation carrier (23). Center drill through rotation shaft and rotation carrier using 1/8" drill.
- (5) Apply small amount of Loctite (3, Appendix A) to rotation shaft where bearing (22) mounts. Attach bearing onto rotation shaft.

(6) Attach rotation carrier (23) to rotation shaft (21) with groove pin (24).

(7) Place retaining ring (28) into housing (29).

(8) Apply a ring of Loctite (3, Appendix A) into housing where internal gear (27) mounts. insert internal gear into housing and spin to spread Loctite.

(9) Apply Loctite (3, Appendix A) onto bearing (22). Apply Lubriplate (4, Appendix A) onto gears attached to rotation carrier (23). insert rotation shaft into housing.

(10) Apply Lubriplate (4, Appendix A) onto gears attached to long carrier plate (18). insert long carrier plate into housing.

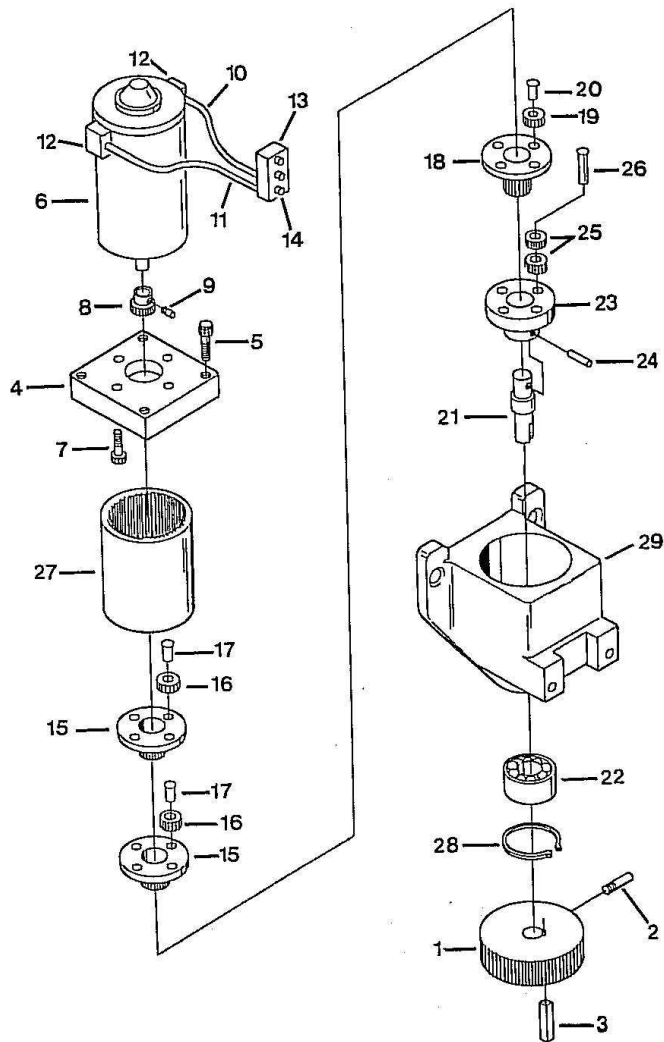

- | | | |
|------------------|--------------------|--------------------|
| 1. Gear | 11. Wire Red | 21. Shaft |
| 2. Screw | 12. Connector | 22. Bearing |
| 3. Key | 13. Housing | 23. Carrier |
| 4. Adapter Plate | 14. Pin Connectors | 24. Pin |
| 5. Screw | 15. Plate | 25. Gear |
| 6. Motor | 16. Gear | 26. Rivet |
| 7. Screw | 17. Rivet | 27. Internal Gear |
| 8. Gear | 18. Plate | 28. Retaining Ring |
| 9. Screw | 19. Gear | 29. Housing |
| 10. Wire, Black | 20. Rivet | |

Figure 2-7 Rotation Gearbox Assembly

(11) Apply Lubriplate (4, Appendix A) onto gears attached to both carrier plates (15). Insert carrier plates into housing.

(12) Apply Loctite (2, Appendix A) to screws (9). Place gauge (7-18-152, paragraph 2-12), between motor face and backside of gear (8). Attach gear (8) to motor (6) with one screw. With a 3/32" drill bit, drill through the remaining hole on the gear, using care not to damage the threads, and place a dimple on the motor shaft. install and tighten remaining screw into gear mounting hole and dimple.

(13) Apply Loctite (2, Appendix A) to screws (7). Attach adapter plate (4) to motor with screws.

(14) Apply Loctite (2, Appendix A) to screws (5). Attach motor to housing (29) with screws.

(15) Attach key (3) and gear (1) onto rotation shaft with screws (2).

(16) Cut a 1 3 length of each wire (10 and 11). Crimp connector (12) on one end of each wire. Connect each wire to motor as color coded.

(17) Crimp pin connectors (14) onto loose end of wires using "certi-crimp" crimp tool (90123- 2, paragraph 2-12). Install pin connectors (14) into connector housing (1 3). Insert red wire into pin 1 of connector, and black wire into pin 2 of connector housing.

e. Installation. Refer to Figure 2-3.

(1) Attach rotation gearbox assembly (51) to turret Inlet elbow (139) with screws (52). Loosen set screws (2, Figure 2-7) and align the rotation gear on the rotation gearbox assembly to line up in the center of the gear on the turret inlet elbow before tightening mounting screws.

(2) Route cable from rotation gearbox assembly to printed circuit board (86, Figure 2-3). Connect plug at end of cable to P7 on printed circuit board.

(3) install rotation feedback assembly (paragraph 2-20).

(4) install false ceiling (paragraph 2-16).

2-22. ELEVATION GEARBOX ASSEMBLY REPAIR.

a. Removal. Refer to Figure 2-3.

(1) Remove false ceiling (paragraph 2-1 6).

(2) Disconnect elevation feedback assembly plug P8 of circuit board (86).

(3) Remove screws (154) and washers (155) attaching brackets (153) to elevation gear- box assembly (53).

(4) Remove two screws (54) attaching elevation gearbox assembly (53) to turret inlet elbow (1 39).

(5) Remove elevation gearbox assembly from roof turret mounting plate.

b. Disassembly. Refer to Figure 2-8.

(1) Remove two screws (2) fastening gear (1) to elevation shaft (18). Remove gear and key (3) from elevation shaft.

(2) Remove four screws (5) attaching motor subassembly to housing (26). Remove motor subassembly from housing.

(3) Remove four screws (7) attaching adapter plate (4) to motor(6). Remove adapter plate from motor.

(4) Remove two screws (9) attaching gear (8) to motor. Remove gear from motor.

(5) If required, disconnect crimp connectors (1 2) from motor and remove crimp connectors from wires (10 and 11). Remove pin connectors (14) from connector housing (13) and remove pin connectors from wire. (6) Remove carrier plate (15) from housing. Remove rivets (1 7) attaching planetary gears (16) to carrier plate. Remove planetary gears from carrier plate.

(7) Remove retaining ring (25) from housing.

(8) Apply sufficient force to outer race of bearing (19) to remove elevation shaft (18) with assembled parts from housing.

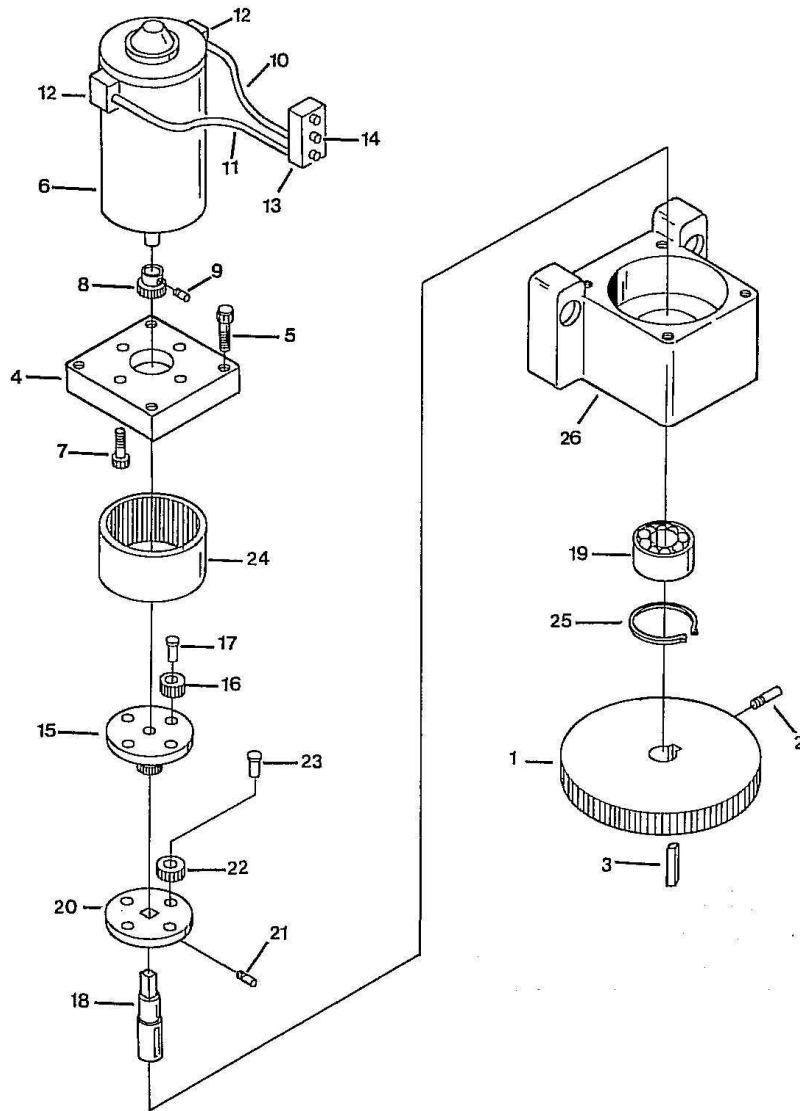

- | | | |
|------------------|--------------------|--------------------|
| 1. Gear | 10. Wire, Black | 19. Bearing |
| 2. Screw | 11. Wire, Red | 20. Carrier |
| 3. Key | 12. Connector | 21. Pin |
| 4. Adapter Plate | 13. Housing | 22. Gear |
| 5. Screw | 14. Pin Connectors | 23. Rivet |
| 6. Motor | 15. Plate | 24. Internal Gear |
| 7. Screw | 16. Gear | 25. Retaining Ring |
| 8. Gear | 17. Rivet | 26. Housing |
| 9. Screw | 18. Shaft | |

Figure 2-8 Elevation Gearbox Assembly

(9) Remove groove pin (21) attaching elevation carrier (20) to elevation shaft. Remove elevation carrier from elevation shaft.

(10) Remove bearing (19) from elevation shaft.

(11) Remove rivets (23) attaching planetary gears (22) to elevation carrier. Remove planetary gears from elevation carrier.

(12) Apply sufficient heat to housing to loosen Loctite on internal gear (24). Remove internal gear from housing.

c. Cleaning and Inspection

Clean and inspect all parts in accordance with paragraph 2-10.

d. Assembly. Refer to Figure 2-8.

(1) Place oil (5, Appendix A) on rivets (17). Peen rivet four gears (16) to carrier plate (15).

(2) Place oil (5, Appendix A) on rivets (23). Peen rivet four gears (22) to elevation carrier (20).

(3) insert elevation shaft (18) into elevation carrier (20). Center drill through elevation shaft and elevation carrier using 1/8" drill.

(4) Apply small amount of Loctite (3, Appendix A) to elevation shaft where bearing (19) mounts. Attach bearing onto elevation shaft.

(5) Attach elevation carrier (20) to elevation shaft (18) with groove pin (21).

(6) Place retaining ring (25) into housing (26).

(7) Apply a ring of Loctite (3, Appendix A) into housing where internal gear (24) mounts. insert internal gear into housing and spin to spread Loctite.

(8) Apply Loctite (3, Appendix A) onto bearing (19). Apply Lubriplate (4, Appendix A) onto gears attached to elevation carrier (20). Insert elevation shaft into housing.

(9) Apply Lubriplate (4, Appendix A) onto gears attached to carrier plate (15) Insert carrier plate into housing.

(10) Apply Loctite (2, Appendix A) to screws (9). Place gauge (7-18-152, paragraph 2-12) between motor face and backside of gear. Attach gear (8) to motor (6) with one screw. With a 3/32" drill bit, drill through the remaining hole on the gear, using care not to damage the threads, and place a dimple on the motor shaft. Install and tighten remaining screw into gear mounting hole and dimple.

(11) Apply Loctite (2, Appendix A) to screws (7). Attach adapter plate (4) to motor with screws.

(12) Apply Loctite (2, Appendix A) to screws (5). Attach motor to housing (26) with screws.

(13) Attach key (3) and gear (1) onto rotation shaft with screws (2).

(14) Cut a 13" length of each wire (10 and 11). Crimp connector (12) on one end of each wire. Connect each wire to motor as color coded.

(15) Crimp pin connectors (14) on the other end of each wire using "certi-crimp" crimp tool (90123-2, paragraph 2-12). Install pin

connectors (14) into connector housing (13). insert red wire into pin 3 of connector, and black wire into pin 2 of connector housing.

e. Installation. Refer to Figure 2-3.

(1) Apply Loctite (3, Appendix A) to screws (54). Attach elevation gearbox assembly (53) to turret inlet elbow (139) with screws. Loosen set screws (2, Figure 2-8) and align the elevation gear on the elevation gearbox assembly to line up in the center of the small gear on the turret inlet elbow before tightening down mounting screws.

(2) Attach brackets (153) to elevation gearbox assembly (53) with screws (154) and washers (155).

(3) Route cable from elevation gearbox assembly to circuit board (86). Connect plug at end of cable to P8 on printed circuit board.

(4) Install false ceiling (paragraph 2-16).

2-23. ELEVATION FEEDBACK ASSEMBLY REPAIR.

a. Removal. Refer to Figure 2-3.

(1) Remove false ceiling (paragraph 2-16).

(2) Disconnect elevation feedback assembly cable plug from P4 of circuit board (86).

(3) Remove screw (58) securing cable clamp (57) to inlet elbow (139). Remove cable clamp.

(4) Remove two screws (61) securing wire clamp (60) to handle bracket adapter (106).

(5) Remove spiral wrap (59) from elevation feedback assembly cable.

(6) Release lock pin (62) from mounting hole in handle yoke (101).

(7) Loosen screws (56) attaching elevation feedback assembly (55) to handle yoke. Loosen screws enough to allow teeth of elevation feedback assembly gear to disengage from teeth on elevation screw (1 14).

(8) Remove feedback cover (64) by grabbing end of cover with pliers and pulling feedback e. cover out through hole in adapter housing.

(9) Carefully pull elevation feedback assembly cable through holes in handle yoke and handle bracket adapter.

b. Disassembly. Refer to Figure 2-9 unless other-wise indicated.

(1) Remove screws (2) attaching cover (1) to elevation feedback pot (8). Remove cover, chain (63, Figure 2-3) and lock pin (62).

(2) Remove screw (4, Figure 2-9) attaching hub (3) to shaft of elevation feedback pot. Re-move hub from shaft.

(3) Remove retaining ring (5) from hub.

(4) Remove gear (6) and spring washer (7) from hub.

c. Cleaning and inspection. Clean and inspect all parts in accordance with paragraph 2-1 0.

d. Assembly. Refer to Figure 2-9 unless otherwise directed.

(1) Place spring washer (7) onto hub (3).

NOTE

Place concave side of spring washer against gear.

(2) Place gear (6) on to hub over spring washer.

(3) Attach retaining ring (5) on hub.

NOTE

Retaining ring fits into gear recess.

(4) Place hub over shaft of elevation feedback pot (8). Apply Loctite (2, Appendix A) to screw (4) and secure hub in place.

(5) Apply Loctite (2, Appendix A) to screws (2). Place chain (63, Figure 2-3) with lock pin (62) over one screw. Attach cover (1, Figure 2-9) to elevation feedback pot with screws. Place screw with chain in the top mounting hole of the cover.

e. Installation. Refer to Figure 2-3.

(1) Feed the elevation feedback assembly cable through the hole in the handle yoke (101) and adapter housing (106).

(2) Insert feedback cover (64) through hole in adapter housing and over elevation feedback assembly cable. Lay feedback cover in cable groove on adapter housing with opening facing down towards handle bracket. Route cable in adapter housing as shown in Figure 2-10.

(3) Align teeth of gear on elevation feedback assembly with teeth of gear on elevation screw (14). Apply Loctite (2, Appendix A) to two screws (56, Figure 2-3). Attach elevation feedback assembly to handle yoke (101) with screws. Do not tighten at this time.

(4) Refer to Figure 2-10. Wrap cable from elevation feedback assembly in the horizontal groove on the adapter housing and through the vertical slot in the adapter housing. Apply Loctite (2, Appendix A) to screws (61, Figure 2-3). Secure the cable in the vertical slot with wire clamp (60) and screws.

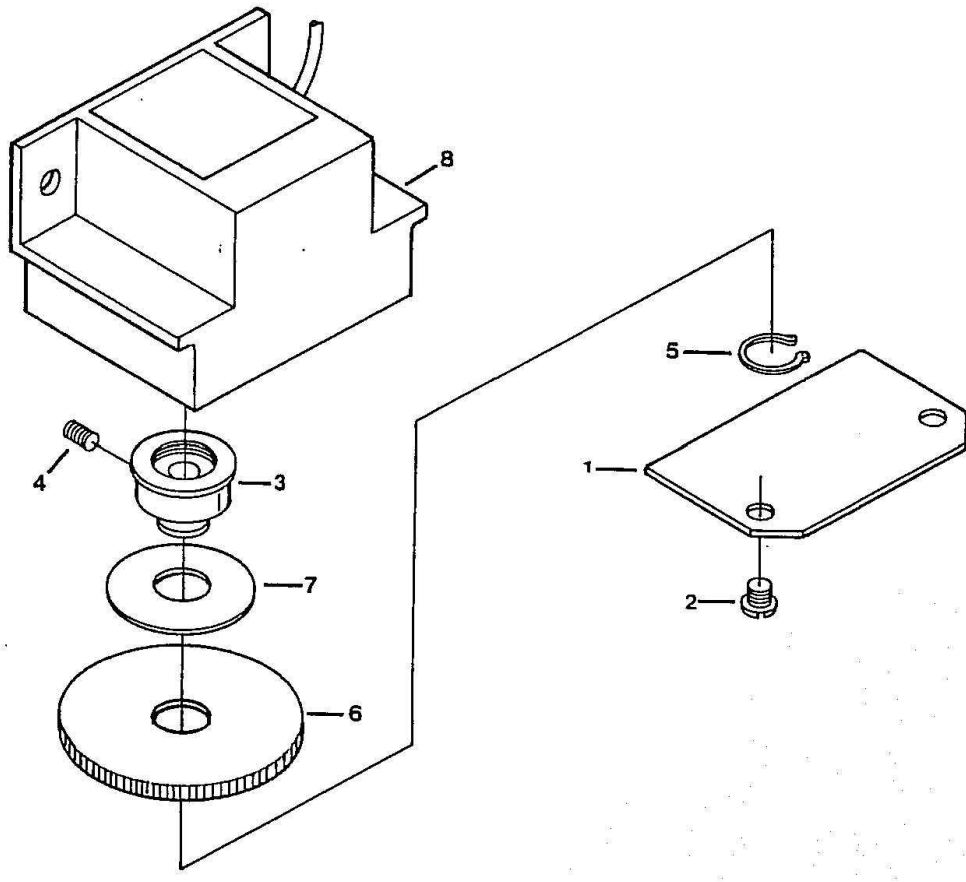

- | | | |
|----------|-------------------|---------------------|
| 1. Cover | 4. Screw | 7. Spring Washer |
| 2. Screw | 5. Retaining Ring | 8. Pot, Subassembly |
| 3. Hub | 6. Gear | |

Figure 2-9 Elevation Feedback Assembly

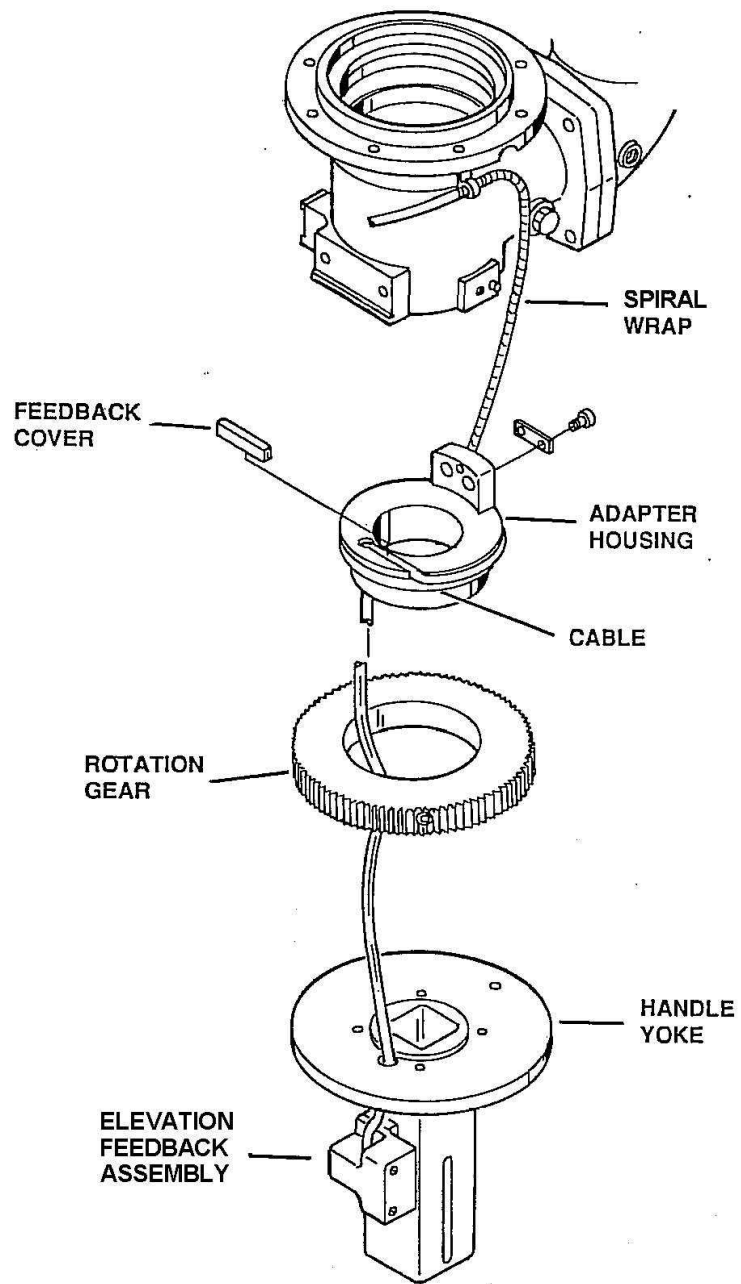

Figure 2-10. Elevation Feedback Assembly Cable Routing.

(5) Starting at wire clamp (60), wrap 20" spiral wrap (59) around elevation feedback as-assembly cable.

(6) Manually rotate turret to the left stop. Pull slack out of elevation feedback assembly cable. Apply Loctite (2, Appendix A) to screw (58). insert spiral wrapped cable into cable clamp (57). Install cable clamp to mounting hole in inlet elbow (139) with screw.

(7) Connect plug of elevation feedback assembly cable to P4 of circuit board (86).

(8) insert lock pin (62) into mounting hole in handle yoke.

f. Adjustment. Refer to Figure 2-3.

(1) Remove set screw (110). Fully insert the screw (109) into the elevation stop nut (112).

(2) Ensure the elevation manual override pin (31) is installed in the mounting hole.

(3) Remove the elevation feedback mounting screws (56) from the elevation feedback assembly (55). Remove the elevation feed-back assembly from the handle yoke (101) until the elevation feedback assembly gear disengages from the elevation screw.

(4) Pull back on the joystick. Quickly rotate the elevation feedback assembly gear clock- wise until the elevation gearbox assembly (53) motor de-energizes. This is the upper elevation limit.

NOTE

Depending on the Initial position of the elevation feedback assembly pot, the elevation gearbox assembly motor may not energize until the gear is rotated clockwise. Once the motor is energized, continue to quickly rotate the gear until the motor de-energizes.

(5) Apply Loctite (2, Appendix A) to screws (56). Attach elevation feedback assembly to handle yoke (101) with screws.

(6) On top of the roof turret, check for 1/16" clearance between top spring washer (44) and elevation clevis (8). If required, remove screws (2, Figure 2-9), cover (1) and chain (63, Figure 2-3) from elevation feedback assembly. With a screwdriver, adjust the feedback pot (8, Figure 2-9) for correct clearance.

(7) Push the joystick forward and hold until the elevation feedback assembly motor de-energizes. Adjust the feedback pot (8) until the lower limit stops the nozzle at 20degreesbelow horizontal.

(8) Unscrew screw (109, Figure 2-3) from the elevation stop nut (112) until it contacts the handle bracket (37). Apply Loctite to set screws (110). Install set screws into elevation stop nut.

(9) Apply Loctite (2, Appendix A) to screws (2, Figure 2-9). Attach cover (1) and chain (63, Figure 2-3) to elevation feedback assembly with screws.

(10) Replace false ceiling (paragraph 2-16).

2-24. RATE CONTROL ASSEMBLY REPAIR.

a. Removal. Refer to Figure 2-3.

(1) Place Override Valve switch to MANUAL.

(2) Remove false ceiling (paragraph 2-1 6).

(3) Disconnect rate cable (30) at rate control assembly (65) end only (paragraph 2-17).

- (4) Label air lines with connection Information. Disconnect air lines from rate control as-assembly.
- (5) Remove cotter pin (1, Figure 2-11) and pin (2) attaching pivot rod (14) to handle hub (22).
- (6) Remove two screws (3) and short collars (4) attaching pivot block (11) to bracket (38). Remove air cylinder (13) from rate control assembly.
- (7) Remove two screws (66, Figure 2-3) attaching rate control assembly (65) to roof turret mounting plate. Remove rate control as-assembly from inside roof turret mounting plate.

b. Disassembly. Refer to Figure 2-11 unless other-wise indicated.

- (1) Compress spring (10, Figure 2-11). Re-move snap ring (8) and nut (9) from spring housing(5). Gently release compression on spring and remove from spring housing.
- (2) Remove two screws (12) attaching pivot block (11) to air cylinder (13).
- (3) Remove pivot rod (14) from air cylinder.
- (4) Remove two fittings (15) and two needle valves (16) from air cylinder.
- (5) Remove two springs (1 7) from rate control assembly.
- (6) Remove spring pivots (19) attaching stand-off (18) to tension links (23 and 24). Remove standoff from tension links.
- (7) Release quick release pin (26) from elevation links (23 and 24). Remove two screws (20) and long collars (21) attaching handle hub (22) and elevation links (23 and 24) to bracket (38).
- (8) Remove screw (27) attaching chain (25) and quick release pin (26) to handle rod (29).
- (9) Remove ball (28) from handle rod (29).
- (10) Apply sufficient heat to handle hub (22) to loosen Loctite. Remove handle rod from handle hub.
- (11) Remove two screws (31) and two washers (32) attaching switch bracket (30) to bracket (38).
- (12) Remove two screws (34) attaching switch (33) to switch bracket.
- (13) Remove two screws (35) from bracket (38).
- (14) Remove two nuts (37) attaching spring pivots (36) to bracket (38).

c. Cleaning and Inspection

Clean and inspect all parts in accordance with paragraph 2-10

d. Assembly. Refer to Figure 2-1 1

- (1) Apply Loctite (2, Appendix A) to screws (1 2). Attach pivot block (11) to air cylinder (13) with screws.
- (2) Attach male fittings (15) to needle valves (16). Apply sealant to air fittings sparingly. Excessive amounts of sealant may clog air lines.
- (3) Apply sealant (7, Appendix A) to threads of needle valves. Thread needle valves into air cylinder (13) and tighten.
- (4) Thread pivot rod (14) into air cylinder and tighten.

- (5) Apply Loctite (2, Appendix A) to threads of spring pivots (36). Attach spring pivots to bracket (38) with nuts (37).
- (6) Apply Loctite (2, Appendix A) to threads of screws (35). Install screws into bracket (38).
- (7) Attach switch (33) to switch bracket (30) with screws (34).
- (8) Attach switch bracket (30) to bracket (38) with screws (31) and washers (32).
- (9) Apply Loctite(2,Appendix A) to inside threads of ball (28). Thread ball onto handle rod (29) and tighten.
- (10) Apply Loctite (2, Appendix A) to threads of screw (27). Attach chain (25) to handle rod with screw.
- (11) Attach quick release pin (26) to chain.
- (12) Insert quick release pin (26) into mounting holes in handle.
- (13) Apply Loctite (2, Appendix A) to threads on end of handle rod opposite bail. Thread handle rod into handle hub (22) and tighten.

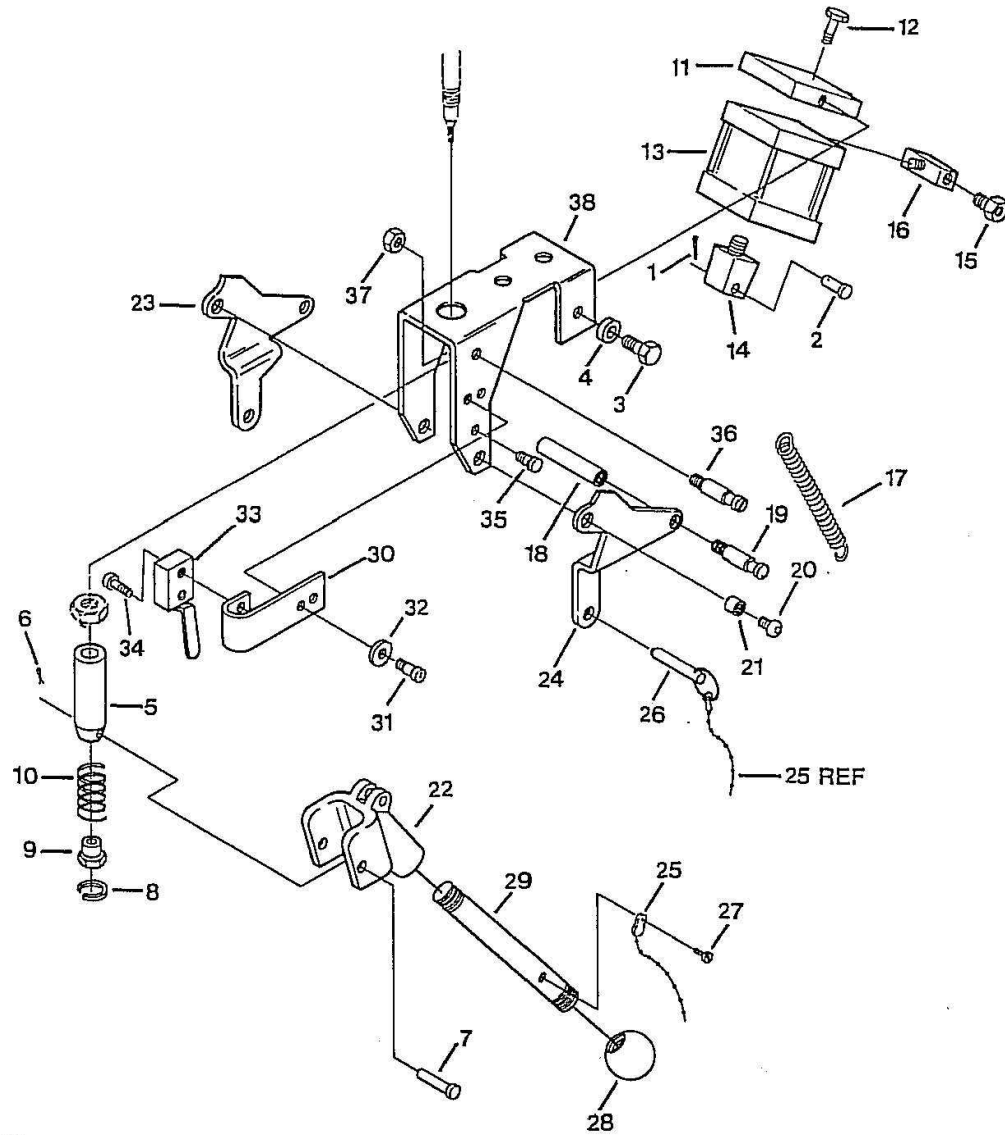

- | | | |
|------------------|------------------|------------------|
| 1. Pin | 14. Pivot Rod | 27. Screw |
| 2. Pin | 15. Fitting | 28. Ball |
| 3. Screw | 16. Valve | 29. Rod |
| 4. Collar | 17. Spring | 30. Bracket |
| 5. Housing | 18. Standoff | 31. Screw |
| 6. Pin | 19. Spring Pivot | 32. Washer |
| 7. Pin | 20. Screw | 33. Switch |
| 8. Snap Ring | 21. Collar | 34. Screw |
| 9. Nut | 22. Hub | 35. Screw |
| 10. Spring | 23. Right Link | 36. Spring Pivot |
| 11. Block | 24. Left Link | 37. Nut |
| 12. Screw | 25. Chain | 38. Bracket |
| 13. Air Cylinder | 26. Pin | |

Figure 2-11 Rate Control Assembly

(14) Apply Loctite (2, Appendix A) to threads in mounting hole of handle hub (22). Place handle hub between bracket (38). Place right tension link (23) and left tension link (24) on each side of bracket and align mounting holes. Attach elevation links and handle hub to bracket (38) with long collars (21) and screws (20).

(15) Apply Loctite (2, Appendix A) to threads of spring pivots (19). Position standoff (18) between tension links on air cylinder side of handle. Attach standoff to tension links with spring pivots.

(16) Attach springs (17) to spring pivots (19 and 36).

(17) Place spring (10) inside spring housing (5). Place spring nut (9) on top of spring. Compress spring and place retaining ring (8), with square edge away from spring, into groove in spring housing. Gently release spring.

e. Installation. Refer to Figure 2-11 unless otherwise indicated.

(1) Thread spring housing (5) onto end of rate cable (30, Figure 2-3).

(2) Apply Loctite (2, Appendix A) to screws (66). Install rate control assembly (65) into roof turret mounting plate with screws.

(3) Attach spring housing (5, Figure 2-11) to handle hub (22) with pin (7). Do not install cotter pin (6) at this time.

(4) Attach pivot rod (14) on air cylinder to handle hub (22) with pin (2) and cotter pin (1).

(5) Attach pivot block (11) to bracket (38) with short collars (4) and screws (3).

(6) Connect air lines to male fittings (15)
f. Adjustment. Refer to Figure 2-11.

(1) Push rate control handle into the HIGH FLOW position. Listen for an audible click as the switch (33) engages. If required, loosen mounting screws (31) on bracket (30) and position bracket for correct switch alignment. Tighten screws.

(2) Adjust rate cable (paragraph 2.17.d).

(3) With turret connected to power source and air supply, adjust needle valves (16) on rate control assembly to obtain smooth slow motion of handle (1-2 seconds per sweep).

(4) Install false ceiling (paragraph 2-16).

2-25. PATTERNCONTROL ASSEMBLY REPAIR.

a. Removal. Refer to Figure 2-3.

(1) Remove false ceiling (paragraph 2-16).

(2) Remove pattern control cable (29) at pattern control assembly (67) only (paragraph 2-17).

(3) Remove screw (68) attaching pattern control assembly to roof turret mounting plate. Remove pattern control assembly from roof turret.

b. Disassembly. Refer to Figure 2-12.

(1) Remove ball (1) from handle rod (2).

(2) Apply sufficient heat to handle hub (3) to loosen Loctite. Remove handle rod from handle hub.

- (3) Remove cotter pin (5) and clevis pin (4) attaching handle hub to pattern bracket (16).
- (4) Remove cotter pins (7) and pins (6) attaching handle hub to cable fitting (8) and pivot rod (15).
- (5) Remove two screws (9) and collars (10) attaching pivot block (11) to pattern bracket (16).
- (6) Remove two screws (12) attaching pivot block to air cylinder (13).
- (7) Remove two fittings (14) from air cylinder.
- (8) Remove pivot rod (15) from air cylinder.

c. Cleaning and inspection. Clean and inspect all parts in accordance with paragraph 2-10.

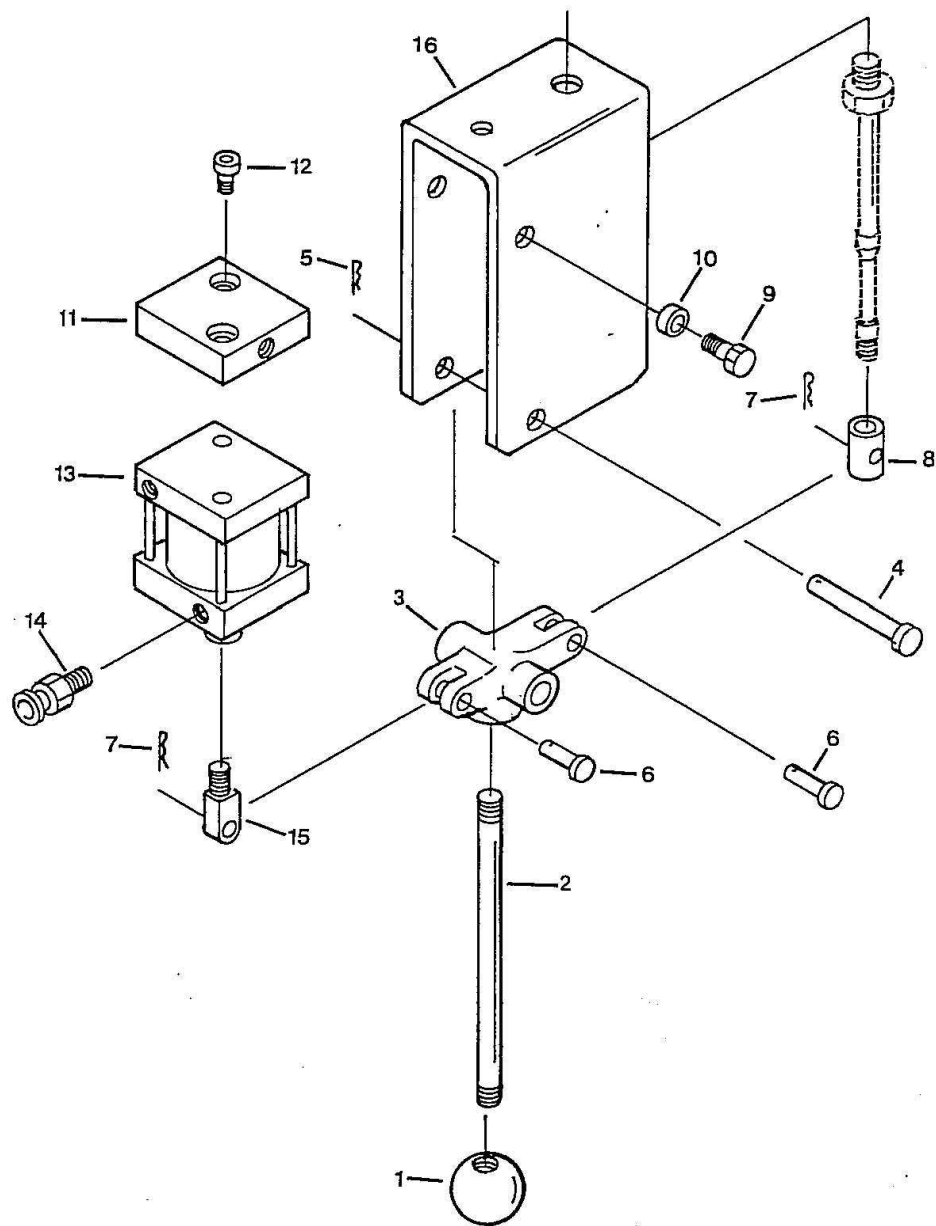

- | | | |
|---------|------------------|------------------|
| 1. Ball | 7. Pin | 13. Air Cylinder |
| 2. Rod | 8. Cable Fitting | 14. Fitting |
| 3. Hub | 9. Screw | 15. Pivot Rod |
| 4. Pin | 10. Collar | 16. Bracket |
| 5. Pin | 11. Pivot Block | |
| 6. Pin | 12. Screw | |

Figure 2-12 Pattern Control Assembly

d. Assembly Refer to Figure 2-12.

- (1) Apply Loctite (2, Appendix A) to screws (1 2). Attach pivot block (11) to air cylinder (13) with screws.
- (2) install two fittings (14) into air cylinder.
- (3) install pivot rod (15) into air cylinder at the opposite end of the pivot block.
- (4) Attach handle hub(3) to pivot rod with pin (6) and cotter pin (7).
- (5) Attach pivot block (11) to pattern bracket (16) with two collars (10) and screws (9).
- (6) Attach handle hub to pattern bracket with clevis pin (4) and cotter pin (5).
- (7) Apply Loctite (2, Appendix A) to ball (1). install bail onto handle rod (2).
- (8) Apply Loctite (2, Appendix A) to end of handle rod. install handle rod into handle hub.

e. Installation. Refer to Figure 2-3.

- (1) Apply Loctite (2, Appendix A) to screw (68). Install pattern control assembly into roof turret mounting plate with screw.
- (2) install and adjust pattern control cable to pattern control assembly (paragraph 2-17).
- (3) Install false ceiling (paragraph 2-1 6).

2-26. SOLENOID VALVE ASSEMBLY REPAIR.

a. Removal. Refer to Figure 2-3.

- (1) Place Override Valve switch to MANUAL.
- (2) Remove false ceiling (paragraph 2-16).
- (3) Disconnect solenoid valve (69) plug from wiring harness.
- (4) Label air lines connected to solenoid valve assembly. Disconnect air lines.
- (5) Remove four screws (70) attaching solenoid valve assembly to roof turret mounting plate. Remove solenoid valve assembly.

b. Disassembly. Refer to Figure 2-13.

- (1) if required, remove tie wraps (1) from wires. Remove pin connectors (2) from connector housing (3).
- (2) Remove screws (5) attaching fog solenoid valve (4) to bracket (19).
- (3) Remove elbow fitting (6) from port B of fog solenoid valve.
- (4) Remove fitting (7) and needle valve (8) from fitting (9) on fog solenoid valve.
- (5) Remove fitting (9) from port B of fog solenoid valve.
- (6) Remove tee fitting (1 0) from exhaust port of fog solenoid valve.
- (7) Remove screws (12) attaching discharge solenoid valve (11) to bracket (19).

(8) Remove elbow fittings (13) from exhaust ports on discharge solenoid valve.

(9) Remove tee fitting (14) from IN port on discharge solenoid valve.

(10) Remove screws (16) attaching stream solenoid valve (15) to bracket (19).

(11) Remove elbow fittings (17) from port A and port B on stream solenoid valve.

(12) Remove tee fitting (18) from exhaust port on stream solenoid valve.

c. Cleaning and inspection.

Clean and inspect all parts in accordance with paragraph 2-10.

d. Disassembly. Refer to Figure 2-13.

(1) Install elbow fittings (17) into port A and Port B on stream solenoid valve (15).

(2) Install tee fitting (18) into exhaust port on stream solenoid valve.

(3) Apply Loctite (2, Appendix A) to screws (1 6). Attach stream solenoid valve to bracket (19) with screws.

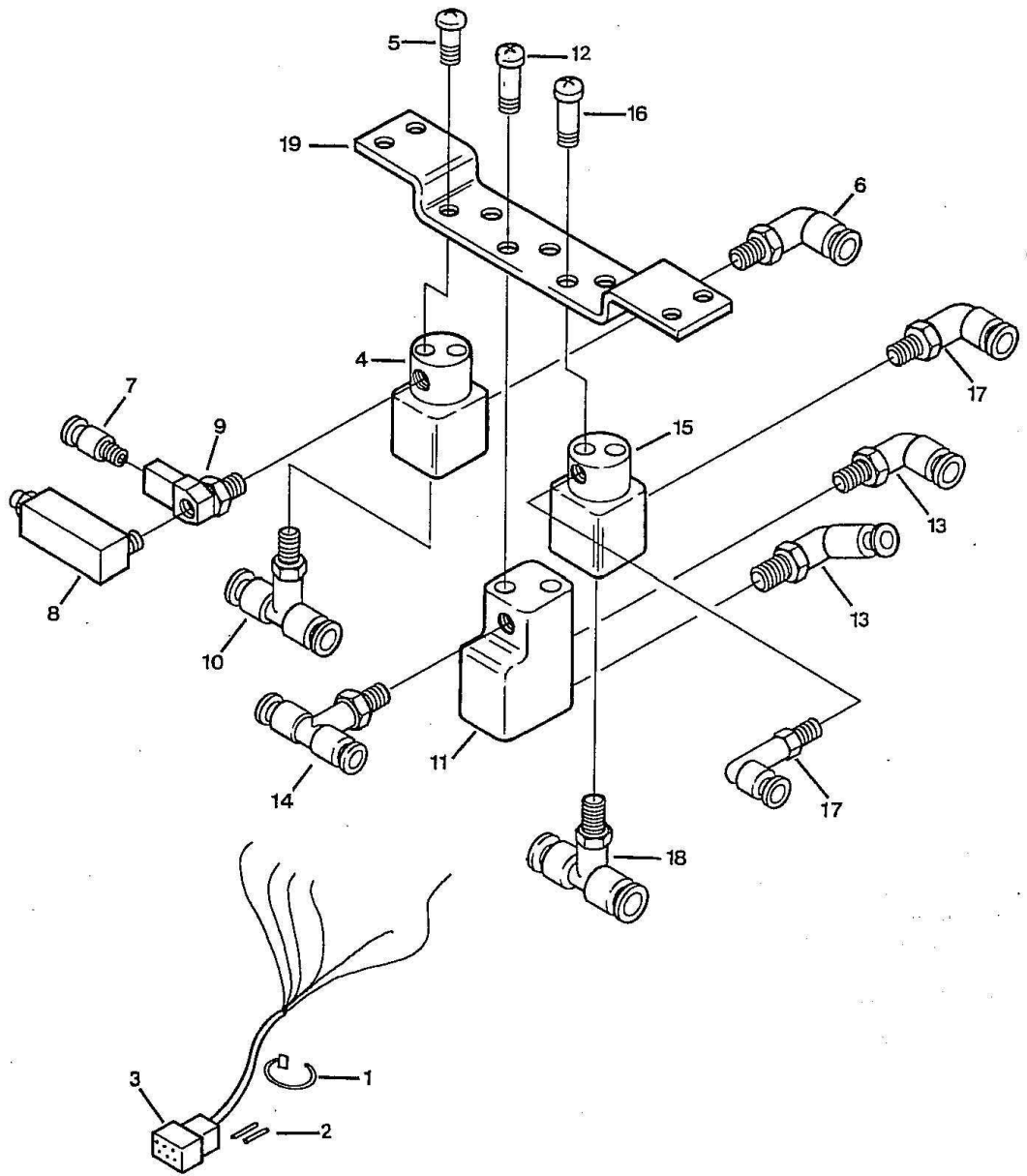

- | | | |
|------------------|-----------------|-------------|
| 1. Tie Wrap | 8. Needle Valve | 15. Valve |
| 2. Pin connector | 9. Fitting | 16. Screw |
| 3. Housing | 10. Tee | 17. Elbow |
| 4. 3-way Valve | 11. Valve | 18. Tee |
| 5. Screw | 12. Screw | 19. Bracket |
| 6. Elbow | 13. Fitting | |
| 7. Fitting | 14. Tee | |

Figure 2-13 Solenoid Valve Assembly

- (4) Attach tee fitting (14) to IN port on discharge solenoid valve (11).
- (5) Attach elbow fittings (13) to both exhaust ports on discharge solenoid valve.
- (6) Apply Loctite (2, Appendix A) to screws (1 2). Attach discharge solenoid valve to bracket (1 9) with screws.
- (7) Attach tee fitting (10) to exhaust port of fog solenoid valve (4). CAUTION Apply sealant to air fittings sparingly. Excessive amounts of sealant may clog air lines.
- (8) Apply sealant (7,AppendixA) to male threads of fitting (9). Attach fitting to port B of fog solenoid valve.
- (9) Attach fitting (7) and needle valve (8) to fitting (9).
- (10) Attach elbow fitting (6) to port B of fog solenoid valve.
- (11) Apply Loctite (2, Appendix A) to screws (5). Attach fog solenoid valve to bracket (19) with screws.
- (12) Bundle wires from solenoid valves together. Cut wires to length so that the shortest wire in the bundle is not less than 6" in length.
- (13) Strip end of each wire and attach a connector pin (2) to the end of each wire.
- (14) Insert the connector pins into the connector housing (3). Refer to Figure B-1 for correct wiring detail.
- (15) Bundle wires using tie wraps (1).

e. Installation.

Refer to Figure 2-3.

- (1) Apply Loctite (2, Appendix A) to screws (70). Attach solenoid valve assembly to roof turret mounting plate with screws.
- (2) Attach air lines to solenoid valve assembly.
- (3) Connect plug on solenoid valve assembly to wiring harness

f. Alignment. Refer to Figure 2-13.

- (1) Adjust needle valve on discharge solenoid valve (I 1) to obtain smooth, slow motion of discharge valve handle.
- (2) Adjust needle valve (8) attached to fog solenoid valve (4) to obtain smooth, slow motion (1-2 seconds per sweep) of pattern control handle.
- (3) Install false ceiling (paragraph 2-16).

2-27. OVERRIDE VALVE ASSEMBLY REPAIR.

a. Removal. Refer to Figure 2-3 unless otherwise directed.

- (1) Remove false ceiling (paragraph 2-16).
- (2) Drain air system. Label and disconnect air lines (14,15 and 16, Figure 2-14) connecting override valve assembly to air accessory tank, air horn, and solenoid valve assembly (71, Figure 2-3).
- (3) Remove two screws (72) connecting over-ride valve assembly to roof turret mounting plate.

b. Disassembly. Refer to Figure 2-14.

- (1) Remove nut and washer attaching toggle valve (1) to bracket (13). Remove toggle valve.
- (2) Remove two elbow fittings (2) from toggle valve.
- (3) Remove elbow fitting (3) from tee fitting (10).
- (4) Remove two nuts (5), washers (6) and screws (7) attaching air regulator bracket (4) to mounting bracket.
- (5) Remove retaining nut attaching air regulator (11) to air regulator bracket (4).
- (6) Remove elbow fitting (8) from adapter fitting (9).
- (7) Remove adapter fitting (9) from outlet port of air regulator (11).

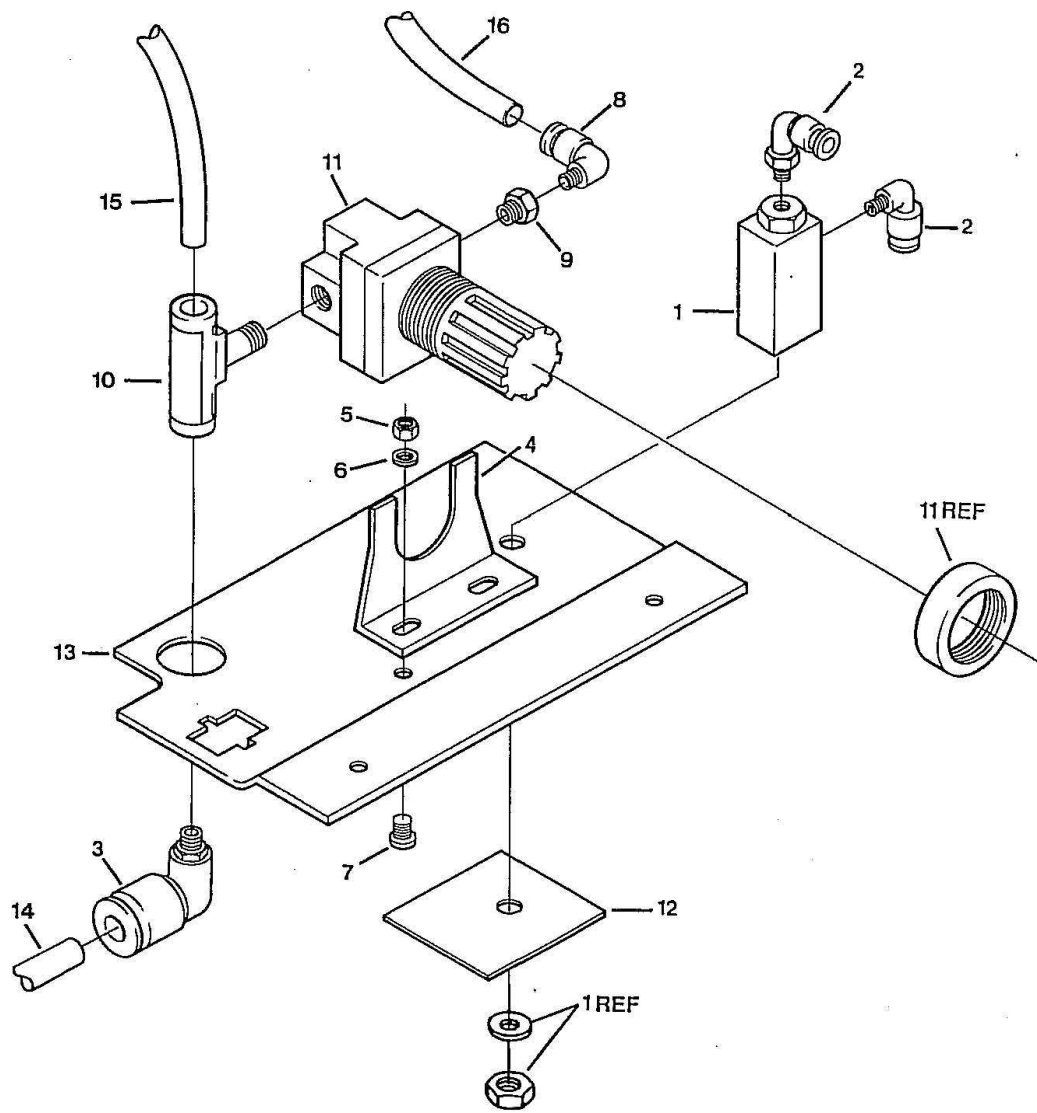

- | | | |
|------------|---------------|---|
| 1. Valve | 8. Fitting | 14. Air Supply Line from
Accessory Tank |
| 2. Fitting | 9. Fitting | 15. Air Supply Line to Air
Horn |
| 3. Fitting | 10. Fitting | 16. Air Supply Line to
Solenoid Valve Assembly |
| 4. Bracket | 11. Regulator | |
| 5. Nut | 12. Label | |
| 6. Washer | 13. Bracket | |
| 7. Screw | | |

Figure 2-14 Override Valve Assembly

(8) Remove tee connector (10) from inlet side of air regulator (11).

(9) If required, remove label (12) from mounting bracket (13).

C. Cleaning and Inspection. Clean and inspect all parts in accordance with paragraph 2-10.

d. Assembly. Refer to Figure 2-14.

CAUTION

Apply sealant to air fittings sparingly. Excessive amounts of sealant may clog air lines.

(1) Apply sealant (7, Appendix A) to male threads of tee fitting (10). Install tee fitting to inlet port of air regulator (11).

(2) Apply sealant (7, Appendix A) to male threads of adapter fitting (9). Install adapter fitting to outlet port of air regulator.

(3) Attach elbow (8) to adapter fitting.

(4) Apply Loctite (2, Appendix A) to screws (7). Attach regulator bracket (4) to mounting bracket (13) with two screws (7), washers (6) and nuts (5). Do not tighten screws at this time

(5) Using supplied retaining nut, attach air regulator (11) to air regulator bracket. Align one end of tee fitting (10) in center of hole in mounting bracket (13). Tighten screws (7).

(6) Attach elbow fitting (3) to tee fitting.

(7) Attach elbow fittings (2) on IN and OUT ports of toggle valve (1).

(8) Clean label mounting area of mounting bracket with alcohol. Attach label (12) to mounting bracket.

(9) Attach toggle valve (1) to mounting bracket (13) using nut and washer provided with toggle valve.

e. Installation- Refer to Figure 2-3.

(1) Apply Loctite (2, Appendix A) on screws (72). Install override valve assembly into roof turret mounting plate with screws.

(2) Connect air lines (14, 15 and 16, Figure 2-14) to override valve assembly.

(3) install false ceiling (paragraph 2-16).

2-28. AIR CYLINDER ASSEMBLY REPAIR.

a. Removal. Refer to Figure 2-3.

(1) Place Override Valve switch to MANUAL.

(2) Remove false ceiling (paragraph 2-16).

(3) Tag air lines with connection information. Disconnect airlines from air cylinder assembly.

(4) Remove cotter pin and pin attaching clevis (76) on air cylinder assembly to three inch valve assembly (133).

(5) Remove four screws (75) attaching air cylinder assembly to roof turret mounting plate. Remove air cylinder assembly from roof turret mounting plate.

b. Disassembly. Refer to Figure 2-3.

- (1) Remove cotter pin and pin attaching swivel bracket (74) to air cylinder (73).
- (2) Remove clevis and jam nut (76) from air cylinder.
- (3) Remove elbow fittings (77) and adapter fittings (78) from air cylinder.

c. Cleaning and inspection. Clean and inspect all parts in accordance with paragraph 2-1 0.

d. Assembly. Refer to Figure 2-3.

- (1) Attach swivel bracket (74) to air cylinder (73) with pin and cotter pin supplied with swivel bracket.

CAUTION

Apply sealant to air fittings sparingly. Excessive amounts of sealant may clog air lines.

- (2) Apply sealant (7, Appendix A) onto adapter fittings (78). Thread adapter fittings onto air cylinder and tighten.
- (3) Thread elbow fittings (77) onto adapter fittings and tighten. Position elbow fittings so that air lines will not be stressed when air cylinder assembly is installed in roof turret mounting plate.
- (4) Thread jam nut and clevis (76) onto air cylinder.

e. installation. Refer to Figure 2-3.

- (1) Apply Loctite (2, Appendix A) onto screws (75). install air cylinder assembly in roof turret mounting plate with screws.
- (2) Attach clevis (76) to handle of three inch valve assembly (1 33) with pin supplied with clevis. Do not install cotter pin at this time.
- (3) Connect airlines, as tagged, to elbow fittings (77).

f. Alignment

- (1) Operate discharge handle over entire range of operation. Verify that the handle makes contact with the stops at each end of the range.
- (2) Remove pin attaching clevis (76) to discharge handle. Adjust the length of the air cylinder shaft as required. Align mounting holes of clevis and discharge handle. Insert pin through mounting holes.
- (3) Recheck the range of the discharge handle. If the setting is not right, repeat step (2) above. When adjustment is correct, install cotter pin into clevis pin.
- (4) Install false ceiling (paragraph 2-16).

2-29. TOGGLE VALVE AND SWITCH BRACKET RE-PAIR.

a. Removal. Refer to Figure 2-3.

- (1) Place Override Valve switch to MANUAL.
- (2) Remove false ceiling (paragraph 2-16).
- (3) Tag air lines with connection Information. Disconnect air lines from the RATE toggle valve (83).

(4) Tag wiring harness with connection information. Disconnect wiring harness (100) from OSCILLATION and DISCHARGE VALVE toggle switches (82).

(5) Remove screws (80) attaching switch bracket (79) to roof turret mounting plate.

(6) Remove nuts attaching toggle switches (82) to switch bracket. Remove toggle switches from switch bracket.

(7) Remove nut attaching toggle valve (83) to switch bracket. Remove toggle valve from switch bracket.

(8) Remove elbow adapters (84) from toggle valve.

(9) Do not remove switch label (81) unless required.

b. Cleaning and inspection. Clean and inspect all parts in accordance with paragraph 2-10.

c. installation. Refer to Figure 2-3.

(1) Clean switch bracket (79) with alcohol. In-stall switch label (81) on switch bracket.

(2) Thread elbow adapters (84) onto toggle valve (83) and tighten.

(3) Attach toggle valve (83) to switch bracket (79) with nut supplied with toggle valve.

(4) Attach toggle switches(82) to switch bracket (79) with nuts supplied with toggle switches.

(5) Apply Loctite (2,AppendIXA) to screws (80). Attach switch bracket to roof turret mounting plate with screws.

(6) Connect wiring harness (100)as tagged, to toggle switches (82) with screws supplied with toggle switches.

(7) Connect airlines, as tagged, to elbow adapters (84) attached to toggle valve (83).

(8) Install false ceiling (paragraph 2-16).

2-30. AIR LINE REPLACEMENT.

a. Removal. Refer to Figure 2-3.

(1) Remove false ceiling (paragraph 2-16).

(2) Drain air system.

(3) Remove cable ties bundling air lines.

(4) Depress red collar on adapter fittings to release air line (85). Carefully remove air line from roof turret mounting plate.

b. installation. Refer to Figure 2-3 unless otherwise indicated.

(1) Cut air line (85) to desired length.

(2) Route air line inside roof turret mounting plate as indicated in Figure 2-15.

(3) Connect air line to adapter fittings by de-pressing red collar on adapter fittings and inserting air line into adapter fitting. Release red collar.

(4) Bundle air lines with cable ties as required.

(5) install false ceiling (paragraph 2-16).

2-31. CIRCUIT BOARD REPAIR.

a. Removal. Refer to Figure 2-3.

(1) Remove false ceiling (paragraph 2-16).

(2) Tag all plugs connected to circuit board (86) with connection information. Disconnect all electrical connections to circuit board.

(3) Remove screws (87) attaching circuit board to circuit board standoffs (88). Remove circuit board from circuit board standoffs (88).

(4) Remove standoffs (88) and screws (89) from roof turret mounting plate.

b. Disassembly. Refer to Figure 2-3.

Remove relays (90) from circuit board (86).

c. Cleaning and inspection. Clean and inspect all parts in accordance with paragraph 2-1 0.

d. Assembly Refer to Figure 2-3. Install relays (90) into circuit board (86).

e. installation Refer to Figure 2-3.

(1) Thread screws (89) into roof turret mounting plate. Tighten until screws are completely through the top of the plate. Apply Loctite (3, Appendix A) to screw threads extending through top of plate. Back screws out of holes until they are flush with outside surface of plate.

(2) Apply Loctite (2, Appendix A) to threads of standoffs (88). Thread standoffs onto screws (89).

(3) Apply Loctite (2, Appendix A) to threads of screws (87). Install circuit board (86) to standoffs (88) with screws.

(4) Connect all electrical connections to circuit board as Identified during removal.

(5) Install false ceiling (paragraph 2-16).

2-32. OSCILLATION LIMIT CONTROL ASSEMBLY REPLACEMENT.

a. Removal Refer to Figure 2-3.

(1) Remove false ceiling (paragraph 2-16).

(2) Disconnect oscillation limit control assembly (91) cable plug from P6 on circuit board (86). Remove cable ties connecting cable to wire bundle.

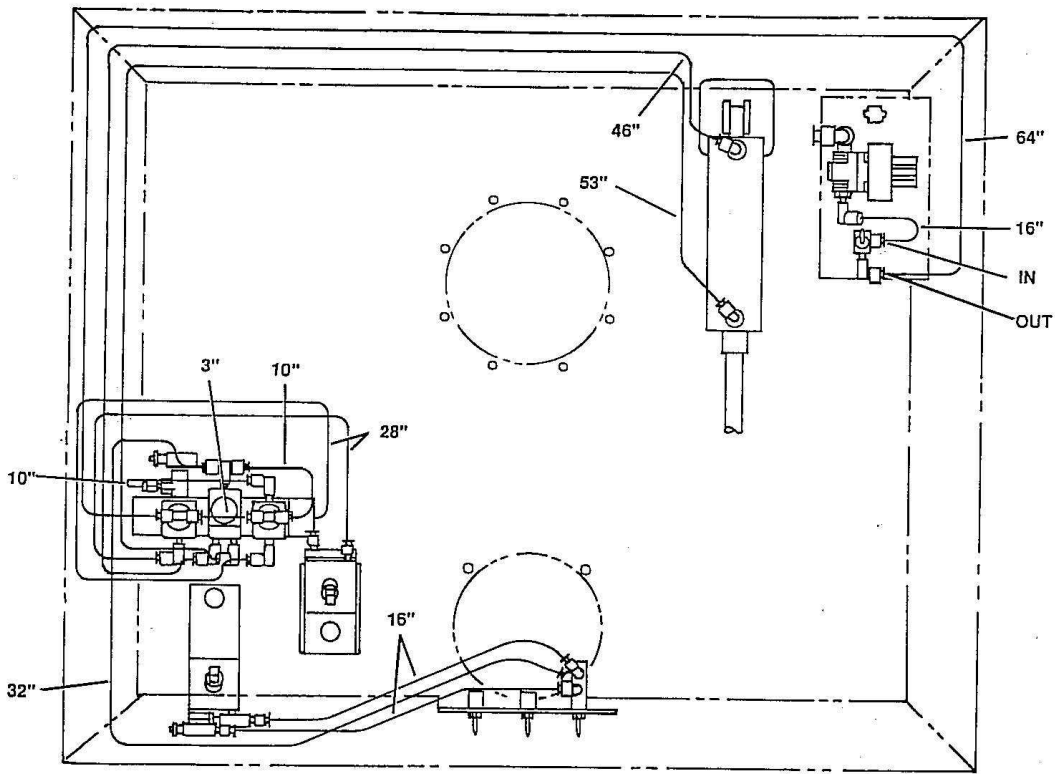

Figure 2-15. Air Lines.

(3) Remove screws (92), washers (93) and cable clamp (94) attaching oscillation limit control assembly to roof turret mounting plate. Re- move oscillation limit control assembly.

b. Cleaning and Inspection

Clean and inspect all parts In accordance with paragraph 2-1 0.

c. installation. Refer to Figure 2-3.

(1) Position oscillation limit control assembly (91) on three inch valve assembly (133) and align mounting holes. Attach wiring harness (100) to assembly with cable clamp (94) and screw (92). Thread remaining screws (92) with washers (93) Into mounting holes and tighten.

(2) Connect oscillation limit control assembly cable plug to P6 on circuit board (86). Attach cable to wire bundle with cable ties.

(3) Replace false ceiling (paragraph 2-16).

2-33. WIRING HARNESS AND POWER CABLE RE-PLACEMENT.

a. Removal. Refer to Figure 2-3.

(1) Remove false ceiling (paragraph 2-16).

(2) Disconnect power cable (96) from truck connection.

(3) Remove nuts (98) and screws (99) connecting cable clamps (97) to roof turret mounting plate Remove cable clamps from around joystick wiring harness (95) and power cable (96).

(4) Disconnect joystick wiring harness (95) plug from P 1on circuit board (86). Disconnect power cable (96) plug from P2 of circuit board.

(5) Remove joystick wiring harness (95) and power cable (96) from roof turret mounting plate.

(6) Remove screw (92) and cable clamp (94) attaching wiring harness (1 00) to oscillation limit control assembly (91).

(7) Tag wiring harness (100) with connection information. Disconnect wiring harness (1 00) at toggle switches (82), rate control assembly (65), solenoid valve assembly (69) and circuit board plug P3. Remove wiring harness from roof turret mounting plate.

b. Cleaning and inspection. Clean and inspect all parts in accordance with paragraph 2-1 0.

c. Installation. Refer to Figure 2-3.

(1) Position joystick wiring harness (95) and power cable (96) in roof turret mounting plate.

(2) Apply Loctite (2, Appendix A) to screws (99). Install cable clamps (97) around joystick wiring harness and power cable and attach to roof turret mounting plate with screws and nuts (98).

(3) Connect joystick wiring harness to P1 of circuit board (86). Connect power cable to P2 of circuit board.

(4) Install wiring harness (100) in roof turret mounting plate and attach to oscillation limit control assembly (91) with cable clamp (94) and screw (92).

(5) Connect wiring harness (1 00), as Identified during removal, to circuit board (86) plug P3, solenoid valve assembly (69), rate control assembly (65) and toggle switches (82).

(6) Connect power cable to truck connection.

(7) Install false ceiling (paragraph 2-16).

2-34. DRIVE ASSEMBLY REPAIR.

a. Removal. Refer to Figure 2-3.

(1) Remove false ceiling (paragraph 2-16).

(2) Remove elevation shaft and handle (paragraph 2-18).

(3) Disconnect elevation feedback assembly cable plug from P4 of circuit board (86).

(4) Remove screw (58) securing cable clamp (57) to inlet elbow (139). Remove cable clamp.

(5) Remove two screws (61) securing wire clamp (60) to handle bracket adapter (106).

(6) Remove spiral wrap (59) from elevation feed-back assembly cable.

(7) Release lock pin (62) from mounting hole in handle yoke (101).

(8) Loosen screws (56) attaching elevation feed-back assembly (55) to handle yoke. Loosen screws enough to allow teeth of elevation feedback assembly gear to disengage from teeth on elevation screw (114). Do not remove elevation feedback assembly at this time.

(9) Manually rotate elevation gearbox assembly (53) gear in the clockwise direction until elevation screw (1 14) is removed from roof turret.

(10) Manually rotate elevation gearbox assembly (53) gear to align the roll pin (107) with the clearance hole in the gear nut (120). Remove roll pin (107) by pushing it through gear nut clearance hole and letting it drop out the bottom of the gear nut. Remove two mounting screws (108) attaching adapter housing (106) to gear nut (120).

(11) Remove four screws (102) attaching handle yoke (101) to adapter housing (106). Re-move handle yoke (101), rotation gear (103) and adapter housing (106) from inside roof turret mounting plate.

(1 2) Remove feedback cover (64) and elevation feedback assembly cable from adapter housing (1 06).

(13) Remove screws (104) attaching horizontal rotation stops (105) to gear (103).

(14) Remove screws (56) attaching elevation feedback assembly (55) to handle yoke. Carefully pull elevation feedback assembly cable through holes in handle yoke (101) and handle bracket adapter.

(1 5) Remove set screw (1 10) and screw (1 09) from elevation stop nut (112).

(1 6) Remove set screw (111) and elevation stop nut (1 12) from handle yoke (101).

(17) Remove beveled washers (1 13) from hole in handle yoke (101).

(1 8) Loosen screws (116) attaching Siamese base adapter (115) to Siamese base (146). Re-move Siamese adapter base with assembled parts from roof turret mounting plate.

(19) Remove screws (1 18) attaching elevation plate (117) to gear nut (120) and remove elevation plate.

(20) Separate Siamese base adapter (1 15) and ball bearings (119) from gear nut (120). (21) If required, remove grip nails (1 22) attaching identification plate (121) to handle yoke(101).

b. Cleaning and Inspect' ton. Clean and inspect all parts in accordance with paragraph 2-10.

c. Installation Refer to Figure 2-3.

(1) Insert screws (116) into Siamese base adapter (115).

(2) Place Siamese base over a 3" long, 2 1/4" OD piece of bar stock. Place 39 ball bearings (1 19) into groove on bottom of Siamese base. Apply lubricant (4,Appendix A) to bail bearings.

(3) Clean threads on gear nut (120). Place the gear nut on top of the bar stock and carefully push the bar stock out of the Siamese base adapter while pushing the gear nut in. En- sure that no ball bearings get into the side holes on the gear nut.

(4) Place 39 ball bearings (1 19) into groove on top of Siamese base adapter (115). Apply lubricant (4, Appendix A) to ball bearings.

(5) Attach elevation plate (1 17) to top of Siamese base adapter with screws (1 18).

(6) Attach the assembled parts to the Siamese base (146) with screws (116) previously Inserted In Siamese base adapter (115). Insure that the two 1/2" tapped holes In the side of the Siamese base adapter are directly In-line with two of the 1/2" tapped Siamese mounting holes in the opposite end of the Siamese base.

(7) If removed, attach identification plate (121) to handle yoke (101) with grip nails (122).

(8) Feed the elevation feedback assembly cable through the hole in the handle yoke (101).

(9) Place rotation gear(103) over adapter housing (106). The side of the rotation gear with the large chamfer on the lock pin mounting hole must face away from the roof turret mounting plate.

(10) Feed the elevation feedback assembly cable through the hole in the adapter housing (106).

(11) Place feedback cover (64) over elevation feedback assembly cable. Lay cable, with feedback cover facing down, linkable groove on adapter housing (105). Route cable in adapter housing as shown In Figure 2-10.

(12) Slide adapter housing over gear nut (120) and secure in place with screws (108) and roll pin (107).

(13) Clean threads of elevation screw(114). Apply lubricant (4, Appendix A) to threads of elevation screw (1 14). Screw the elevation screw into the gear nut(120). The gear teeth on the elevation screw must line up with the outlet tee (1 2).

(14) Apply lubricant (4, Appendix A) to sides of elevation screw (1 14). Slide handle yoke (101) over elevation screw (114). Attach handle yoke to adapter housing with four screws (102).

(15) Align teeth of gear on elevation feedback assembly with teeth of gear on elevation screw (114). Apply Loctite (2, Appendix A) to two screws (56). Attach elevation feed-back assembly to handle yoke with screws.

(16) Refer to Figure 2-10. Wrap cable from elevation feedback assembly in the horizontal groove on the adapter housing and through the vertical slot in the adapter housing. Apply Loctite (2, Appendix A) to screws (61, Figure 2-3). Secure the cable in the vertical slot with wire clamp(60) and screws.

(17) Starting at wire clamp (60), wrap 20" spiral wrap (59) around elevation feedback as-assembly cable.

(18) Manually rotate turret to the left stop. Pull slack out of elevation feedback assembly cable. Apply Loctite (2, Appendix A) to screw (58). Insert spiral wrapped cable into cable clamp (59). Install cable clamp to mounting hole in inlet elbow (139) with screw.

(19) Connect plug of elevation feedback assembly cable to P4 of circuit board (86).

(20) Install handle bracket (paragraphs 2-18.c (6) through 2-18.c (9)).

(21) Stack four spring washers (113) so they oppose each other. Place spring washers into the one inch hole on handle yoke (101).

(22) Thread elevation nut (112) into one inch hole in handle yoke (101) and tighten.

(23) Apply Loctite (2, Appendix A) to set screw (111). Secure elevation nut in place with set screw. Tighten set screw, then back out 1/4 turn.

(24) Thread screw (109) into elevation nut (112) and tighten. Secure screw in place with set screw (110) and tighten.

(25) Insert lock pin (62) into mounting hole in handle yoke.

(26) Adjust elevation feedback assembly (paragraph 2-23.f).

2-35. DRAIN VALVE ASSEMBLY REPAIR.

a. Removal. Refer to Figure 2-3.

(1) Remove false ceiling (paragraph 2-16).

(2) Disconnect truck drain hose and adapter from elbow fitting (123).

(3) Remove nut (127), washer (128) and screw (126) securing support strap (125) to driver's side of roof turret mounting plate. Remove screw (130) attaching other end of support strap to three inch valve assembly (133). Remove support strap from roof turret mounting plate.

(4) Remove elbow fitting (123) from drain valve assembly.

(5) Remove drain valve assembly (124) from inlet elbow (139).

b. Disassembly Refer to Figure 2-16. REPAIR.

(1) Remove retaining ring (1) from drain valve body (4).

(2) Remove poppet (2) and spring (3) from drain valve body.

c. Cleaning and inspection. Clean and inspect all parts in accordance with paragraph 2-10.

d. Assembly Refer to Figure 2-16.

(1) Insert spring (3) into drain valve body (4).

(2) Insert poppet (2) into center of spring.

(3) Compress spring (3) and poppet (2) into drain valve body and install retaining ring (1).

e. Installation. Refer to figure 2-3.

(1) Apply sealant (7, Appendix A) to threads of drain valve assembly. Thread drain valve assembly (124) into inlet elbow (139) and tighten

(2) Apply sealant (7, Appendix A) to threads of elbow fitting (123). Thread elbow fitting into drain valve assembly and tighten.

(2) Secure support strap (125) to three inch valve assembly (133) with screw (130). Attach other end of support strap of roof turret mounting plate with screw (126), washer (128) and nut (127).

CAUTION

Insure that the elevation feedback cable is placed between the turret inlet elbow and truck drain line. Failure to do so will cause the elevation feedback cable to break when the turret is rotated from side to side.

(4) Connect truck drain hose and adapter to elbow fitting (123).

(5) Replace false ceiling (paragraph 2-16)

a. Removal. Refer to Figure 2-3,

(1) Remove false ceiling (paragraph 2-1 6).

(2) Remove oscillation limit control assembly (paragraph 2-32).

(3) Remove pin attaching clevis (76) to three inch valve assembly (133).

(4) Remove screws (1 26), nuts (127), and washers (128) attaching support straps (125) to roof turret mounting plate.

(5) Remove bolts (130) attaching support straps (125) and bracket (129) to inlet elbow side of . . . three inch valve assembly (133).

(6) Remove screws (132) attaching victaulic inlet (131) to roof turret mounting plate.

(7) Remove mounting screws (134) attaching three inch valve assembly (133) to inlet elbow (139) and victaulic inlet (131). Remove three inch valve assembly, victaulic inlet, gasket (135), and gasket (136) form roof turret mounting plate

b. Disassembly. Refer to Figure 2-17 unless otherwise indicated.

(1) With three inch valve assembly in the closed position, remove two valve seats (1) from valve body (1 9).

(2) Remove screw (3) and washer (4) attaching air cylinder arm (2) to trunnion (12).

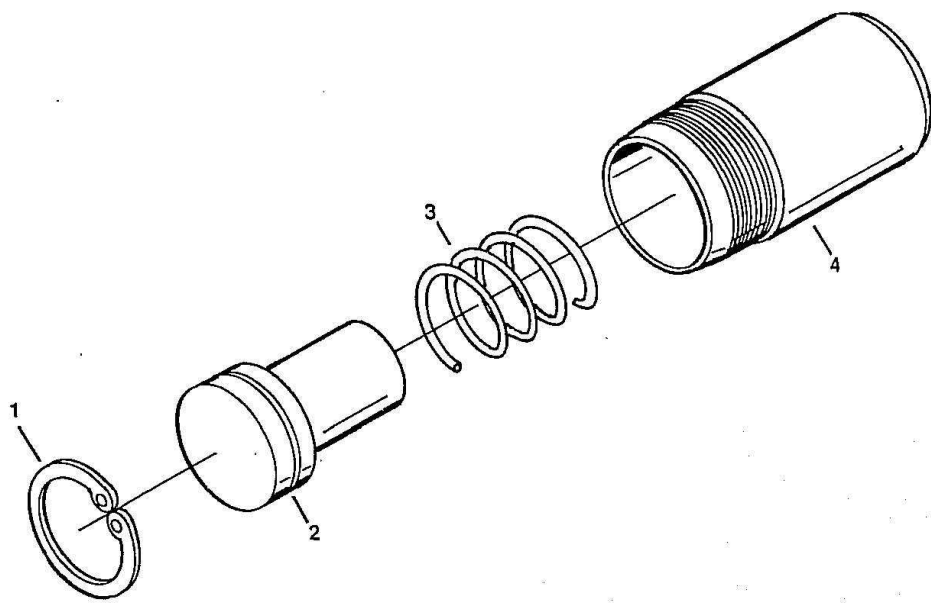

- 1. Ring
- 2. Poppet
- 3. Spring
- 4. Body

Figure 2-16 Drain Valve Assembly

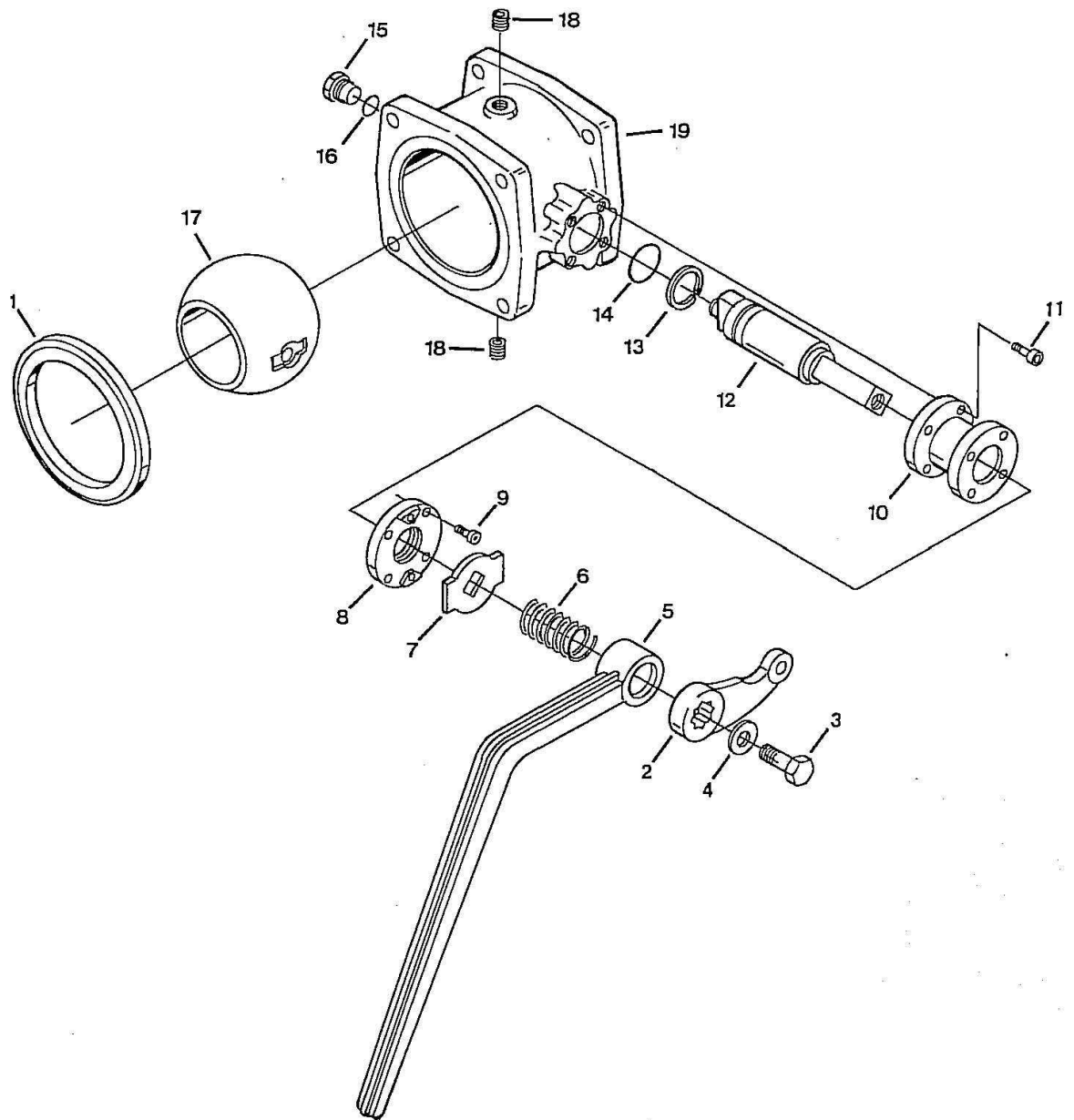

- | | | |
|---------------|--------------|----------------|
| 1. Valve Seat | 8. Plate | 15. Trunnion |
| 2. Arm | 9. Screw | 16. O-Ring |
| 3. Screw | 10. Housing | 17. Ball |
| 4. Washer | 11. Screw | 18. Plug |
| 5. Handle | 12. Trunnion | 19. Valve Body |
| 6. Spring | 13. Ring | |
| 7. Plate | 14. O-Ring | |

Figure 2-17 Three Inch Valve

- (3) Remove valve handle (5), spring (6) and stop plate (7) from trunnion.
 - (4) Remove screws (9) attaching retaining plate (8) to trunnion housing (10).
 - (5) Remove screws (11) attaching trunnion housing (10) to valve body. Remove trunnion housing.
 - (6) Remove trunnion (12) from valve body (19).
 - (7) Remove retaining ring (13) and O-ring (14) from trunnion (12).
 - (8) Remove threaded trunnion (15) from valve body (19).
 - (9) Remove O-ring (1 6) from threaded trunnion (15).
 - (10) Remove bail (17) from valve body (19).
 - (11) Remove pipe plugs (18) from valve body (19).
 - (12) Remove pipe plug (137, Figure 2-3) from victaulic inlet (131). e.
- c. Cleaning and Inspection. Clean and inspect all parts in accordance with paragraph 2-10.
- d. Assembly Refer to Figure 2-17 unless otherwise indicated.
- (1) Apply sealant (7, Appendix A) to threads of pipe plugs (1 8). Thread pipe plugs into valve body (19) and tighten.
 - (2) Apply grease (1, Appendix A) to O-ring (1 6). Place O-ring onto threaded trunnion (15). Screw threaded trunnion into valve body (19). Do not tighten at this time.
 - (3) Position ball (17) into valve body (19) and align mounting hole with threaded trunnion (15). Tighten threaded trunnion.
 - (4) Apply grease (1, Appendix A) to O-ring (14). Place O-ring onto trunnion (12). Attach retaining ring (13) onto trunnion. Insert trunnion into valve body (19) and into mounting hole in bail (17).
 - (5) Slide trunnion housing (10) over trunnion. Attach trunnion housing to valve body (19) with screws (11).
 - (6) Slide retaining plate (8) over trunnion. Attach retaining plate to trunnion housing (10) with screws (9).
 - (7) Slide stop plate (7) over trunnion (12).
 - (8) Slide spring (6) over trunnion (12).
 - (9) Position handle (5) onto trunnion (12).
 - (10) Position air cylinder handle (2) onto trunnion (12).
 - (11) Place washer (4) and screw (3) over trunnion (12) and tighten.
 - (12) With the ball(17) in the closed position, press valve seats (1) into valve housing (19).
 - 13) Apply sealant (7, Appendix A) to threads of pipe plug (137, Figure 2-3). Thread pipe plug into victaulic inlet (131) and tighten.
- e. Installation. Refer to Figure 2-3.

- (1) Place gasket (135) between three inch valve assembly (133) and victaulic inlet (131) and align mounting holes. Thread two screws (134) into upper mounting holes and tighten.
- (2) Place gasket (136) over victaulic inlet (131). Insert victaulic inlet through hole in roof turret mounting plate. Thread screws (132) through mounting holes in roof turret mounting plate into victaulic inlet. Do not tighten at this time.
- (3) Place gasket (135) between three inch valve assembly (133) and inlet elbow (139). Attach three inch valve assembly to inlet elbow with two screws (134) in upper mounting holes and tighten. Tighten victaulic inlet mounting screws (132).
- (4) Attach bracket (129) and support straps (325) to three inch valve assembly (133) with screws (130) and tighten.
- (5) Attach support straps (125) to roof turret mounting plate with screws (126), washers (128) and nuts (127) and tighten.
- (6) Attach bracket (129) to three inch valve assembly (133) with two screws (130) and tighten.
- (7) Attach clevis (76) to three inch valve assembly (133) with pin supplied with clevis.
- (8) install oscillation limit control assembly (paragraph 2-32).
- (9) Install false ceiling (paragraph 2-16). 2-37. INLET WATERWAY REPAIR.

a. Removal. Refer to Figure 2-3.

- (1) Remove false ceiling (paragraph 2-16).
- (2) Remove Siamese (paragraph 2-19).
- (3) Remove elevation gearbox assembly (paragraph 2-22).
- (4) Remove drive assembly (paragraph 2-34).
- (5) Remove drain valve assembly (paragraph 2-35).
- (6) Remove three inch valve (paragraph 2-36).
- (7) Remove O-ring (138) from groove formed by Siamese base (146) and inlet elbow (139).
- (8) Remove screws (140) attaching Inlet elbow (139) to roof turret mounting plate. Remove inlet elbow with attached parts from roof turret mounting plate.
- (9) Remove gasket (141) from inlet elbow.

b. Disassembly Refer to Figure 2-3.

- (1) Remove plug (142) from inlet elbow (139). Remove bail bearings (143) from lower groove in inlet elbow.
- (2) Remove plug (144) from inlet elbow (139). Remove ball bearings (145) from upper groove in inlet elbow.
- (3) Remove Siamese base (146) from inlet el-bow (139).
- (4) Apply sufficient heat to Siamese base to loosen Loctite. Remove O-ring bushing (147) by pushing it through top of Siamese base.

(5) Remove O-ring (1 48) from outside diameter of O-ring bushing (147). Remove O-ring (149) from inside of O-ring bushing.

(6) Remove O-ring (150) from bottom of Siamese base (146).

(7) Remove O-ring (151) from upper groove on Siamese base (1 46).

(8) If required, remove grease fittings (152) from inlet elbow (139).

c. Cleaning and inspection Clean and inspect ail parts in accordance with paragraph 2-1 0.

d. Assembly. Refer to Figure 2-3.

(1) If removed, press grease fittings (152) into inlet elbow (139).

(2) Apply grease (1, Appendix A) on O-ring (151). Install O-ring into upper groove on Siamese base (1 46).

(3) Apply grease (1, Appendix A) on O-ring (150). install O-ring in lower groove on Siamese base (146).

(4) Place O-ring (148) onto outside diameter of O-ring bushing (147). Do not grease O-ring.

(5) Apply grease (1, Appendix A) on O-ring (149). Install O-ring in inside groove on O-ring bushing (147).

(6) Apply Loctite (12, Appendix A) to outside diameter of O-ring bushing (147). insert O-ring bushing into top of Siamese base (146).

(7) Apply grease (1, Appendix A) to O-ring surfaces on the inside of the inlet elbow (139). Insert Siamese base (146) into inlet elbow.

(8) Insert 41 ball bearings (145) into the upper groove on the inlet elbow. Thread plug (144) Into inlet elbow (139) and tighten.

(9) Insert 36 ball bearings (1 43) into lower groove on the inlet elbow. Thread plug (144) into inlet elbow (139) and tighten.

e. installation Refer to Figure 2-3.

(1) Place gasket (141) onto top of inlet elbow (139).

(2) Apply Loctite (2, Appendix A) to threads of screws (140). Insert the inlet elbow (139) up through the hole in the roof turret mounting plate. Attach inlet elbow to roof turret mounting plate with screws and tighten.

(3) Place O-ring (1 38) into the groove formed by the Siamese base (146) and the turret inlet elbow (139).

(4) Install three Inch valve (paragraph 2-36).

(5) Install drain valve assembly (paragraph 2- 35).

(6) Install drive assembly (paragraph 2-34).

(7) Install elevation gearbox assembly (paragraph 2-22).

(8) Install Siamese (paragraph 2-19).

(9) Apply lubricant (4, Appendix A) to grease fittings (152).

(10) Install false ceiling (paragraph 2-16).

2-38. MOUNTING PLATE REPAIR.

a. Disassembly Refer to Figure 2-3.

- (1) Remove false ceiling (paragraph 2-16).
- (2) Remove screws (154) and washers (155) attaching brackets (153) to elevation gear-box assembly (53).
- (3) Remove screws (156), nuts (157) and washers (155) attaching brackets (153) to roof turret mounting plate (162) and remove brackets.
- (4) Remove stud clips (158) from roof turret mounting plate mounting holes.
- (5) Remove screws (159) and standoffs (160) attaching air horn subassembly to roof turret mounting plate.
- (6) If required, remove insulation (161) from roof turret mounting plate.

b. Cleaning and inspection Clean and inspect all parts in accordance with paragraph 2-10.

c. Assembly Refer to Figure 2-3.

- (1) Apply adhesive (13, Appendix A) to back-side of insulation pieces (161). install insulation into roof turret mounting plate (162).
- (2) Attach air horn subassembly to roof turret with standoffs (160) and screws (159).
- (3) Attach stud clips (158) around each mounting hole in roof turret mounting plate.
- (4) Attach brackets (153) to roof turret mounting plate with screws (156), washers (155) and nuts (157). Before tightening screws, apply bead of polyurethane sealant (6, Appendix A) around screws.
- (5) Attach brackets (1 53) to elevation gearbox assembly (53) with screws (154) and washers (155).
- (6) Install false ceiling (paragraph 2-16).

2-39. JOYSTICK REPLACEMENT.

a. Operational Check. Perform the tests listed in Table 2-5 to determine if an electrical problem exists in the joystick circuitry. Hold the joystick control in the position described and check for electrical continuity between the pins listed on the male half of the nine-pin connector.

NOTE

Remove 10 screws attaching top panel to center control console. Lift panel enough to provide access to joystick electrical connector.

b. Removal. Refer to Figure 2-18.

- (1) Remove 10 screws (1) attaching top panel (2) to center console. Lift top panel enough to provide access to underside of joystick (3).
- (2) Disconnect joystick electrical plug and ground.

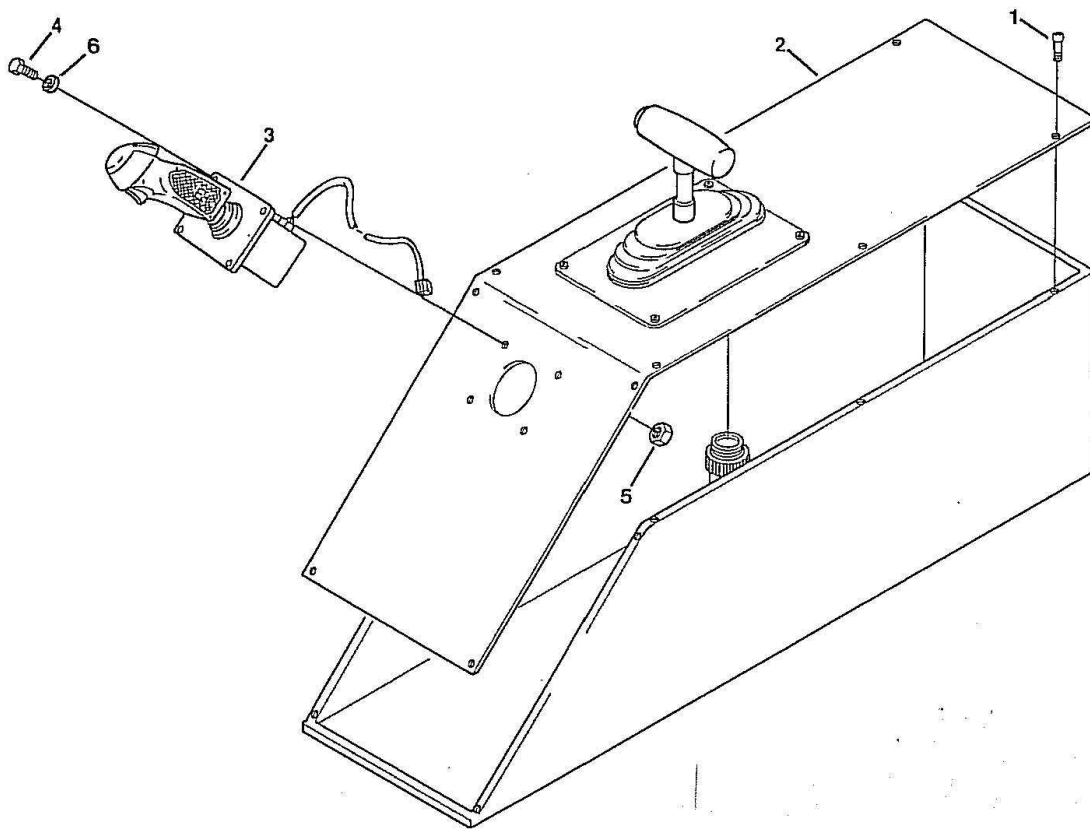

- 1. Screw
- 2. Top Panel
- 3. Joystick
- 4. Screw
- 5. Nut
- 6. Washer

Figure 2-18 Joystick Removal/Installation

(3) Remove four screws (4), nuts (5), and flat washers (6) attaching joystick (3) to top panel (2). Remove Joystick Assembly

c. Installation Refer to Figure 2-18

(1) Install joystick (3) on top panel (2) with four screws (4), nuts (5), and flat washers (6)

(2) Connect joystick electrical plug and ground.

(3) Attach top panel (2) to center control console with 10 screws (1).

Table 2-5 Joystick Electrical Analysis

Function	Control Position	Pins
Discharge	Discharge trigger squeezed in	6&9
Pattern	Rocker switch to the left (center off)	8&9
Pattern	Rocker switch to the right (center off)	7&9
Elevate	Joystick Back	5&9
Depress	Joystick Forward	4&9
Rotate Right	Joystick Right	2&9
Rotate Left	Joystick Left	1&9

Note: Pin 3 is not used.

CHAPTER 3. Illustrated Parts Breakdown
SECTION I
INTRODUCTION

3-1. PURPOSE.

This Illustrated Parts Breakdown lists and describes the parts of the Akron Brass Type I Roof Turret for the USAF Type A/S32P-23 Crash Fire Rescue Truck (CFR). The roof turret is manufactured by Akron Brass Company, Wooster, OH 44691

3-2. MAINTENANCE PARTS LIST (MPL).

The MPL contains a breakdown of all groups, installations, assemblies, and parts of the roof turret. The MPL has an illustration which is keyed to the parts list. The MPL is arranged in seven columns, which are explained in the following paragraphs.

a. Figure and Index Number Column. The figure number identifies the illustration. This figure number appears at the beginning of each page or listing. The index number identifies each part shown on the illustration and listed on the parts list. The index numbers are arranged in sequence and generally reflect the order of disassembly. When it is necessary to use two or more pages to illustrate a particular installation or as-assembly, each page of the illustration is numbered (example: Sheet 1 , Sheet 2, etc.).

b. Part Number Column. The part number column contains the manufacturer's, vendor's, or government standard part number assigned as required by MIL-STD-100. In instances where no part number exists for a specific part, installation, or group of related parts, the words 'NO NUM-BER" are inserted in the part number column. Where applicable, reference is made in the description column to the figure that illustrates and lists the parts.

c. Commercial and Government Entity (CAGE)Column The CAGE column contains the five-digit code for manufacturers, vendors, and government standard parts. Refer to paragraph 3-4for a complete list of CAGE Codes used in this manual, with names and addresses of the manufacturers.

d. Description Column the description column gives the full nomenclature used to identify the installation, assembly, or part. For government standard parts, only the noun is listed. When installations or assemblies are listed, reference is given to the figure on which the detailed parts are listed. When the installation or assembly detailed parts are listed, they are indented to show relationship to the installation or assembly. Each assembly is followed immediately by as component parts. An assembly beginning in column '1' has its detail parts beginning in column '2'. If a detail part is in turn an assembly, as detail parts begin in column "3" etc. Attaching parts are identified by the letters '(AP)' and are listed immediately following the assembly or part they attach.

e. Units Per Assembly Column. The units per assembly column lists the quantity of each part required for the next higher assembly. The letters "AR' indicate the part is to be used as required. "REF" (reference) is used when the part has been previously listed and illustrated, with proper quantity, and is listed again for reference purposes only.

f. Usable On Code Column. The usable on code column indicates the difference in assemblies when two or more assemblies are listed on the same parts list. The letters A, B, etc. are used in the code column to indicate the difference. When component parts for each assembly listed on a parts list are the same, this column is left blank

g. Source Maintenance and Recoverability (SMR) Code Column. The SMR code column contains the Joint Military Services Uniform Codes only. Definitions of SMR Codes are contained in TO 00-25-1 25.

3-3. COMMERCIAL AND GOVERNMENT ENTITY (CAGE) CODES AND ADDRESSES.

The following list is a compilation of the vendor codes with the name and addresses of suppliers for purchased and vendor parts listed in this publication. The list is arranged in alphanumeric order.

CODE NAME AND ADDRESS

00912 Akron Brass Co.

343 Venture Blvd
Wooster, OH 44691

02978 Teledyne Continental
Motors General Products Division
76 Getty Street
Muskegon, MI 49442-1238

3W155 R B and W Fastening Service CE Division of R B and W Corporation
1087 Andover Pk E.
Seattle, WA 98188-7615

3-4. HOW TO USE THE ILLUSTRATED PARTS BREAKDOWN.

An explanation of how to use the illustrated parts breakdown is provided below

1. Determine the function and application of the part required. Turn to the list of Illustrations and select the most appropriate figure. Note the page number
2. Turn to the page indicator and locate the desired part or assembly on the illustration.
3. From the illustration, obtain the index number assigned to the part desired. Refer to the accompanying description for specific information regarding the part.

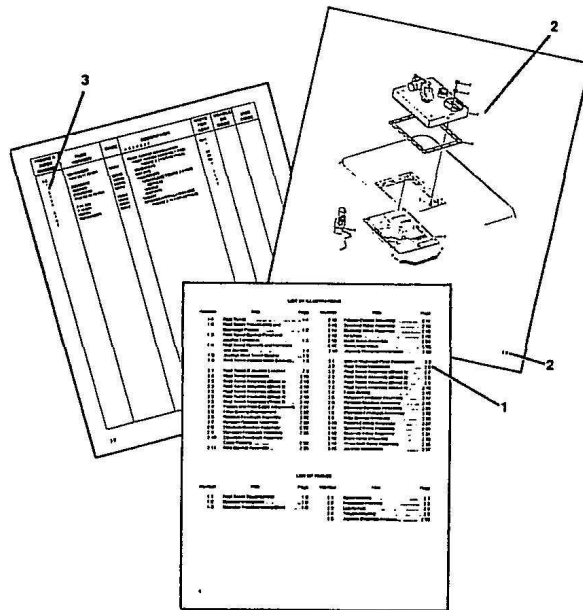

Figure 3-1 Use of illustrated Parts Breakdown

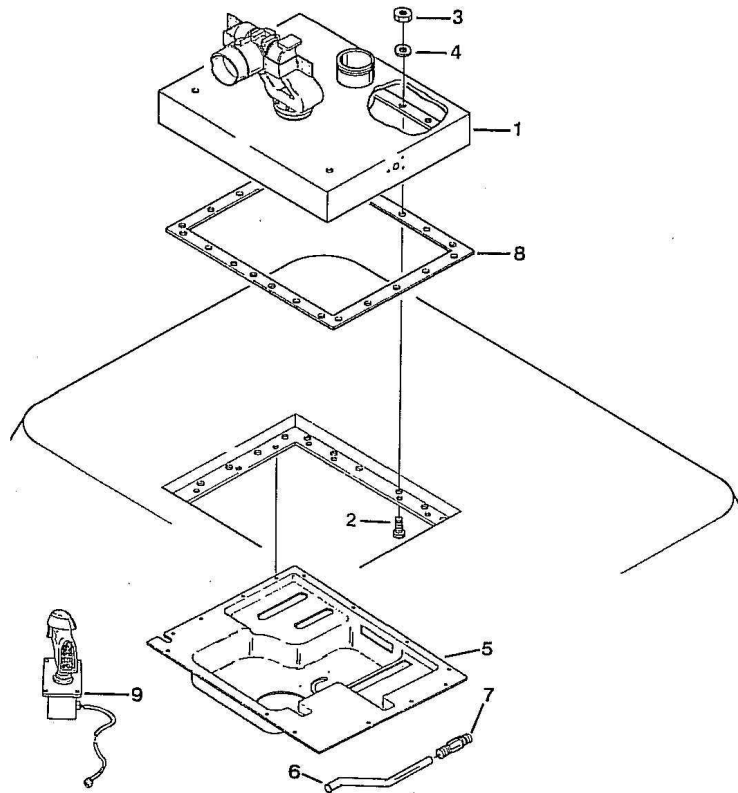

Figure 3-2. Roof Turret Installation.

Figure & Index Number	Part Number	Cage	Description	Units Per Assy
3-2	No Number		Roof Turret Installation	REF
3-1		00912	Roof Turret Assembly (See figure 3-3 for details)	1
3-2	2cd120372	3w155	Screw	22
3-3	3cd3798	3w155	Nut	22
3-4	2w0202768	3w155	Washer	22
3-5	34670048	00912	Ceiling (See figure 3-4 for details)	1
3-6	704325	00912	Handle	1
3-7	718071	00912	Grip	1
3-8	602494	02978	Gasket	1
3-9	No Number	00912	Joystick Installation (see figure 3-15 for details)	1

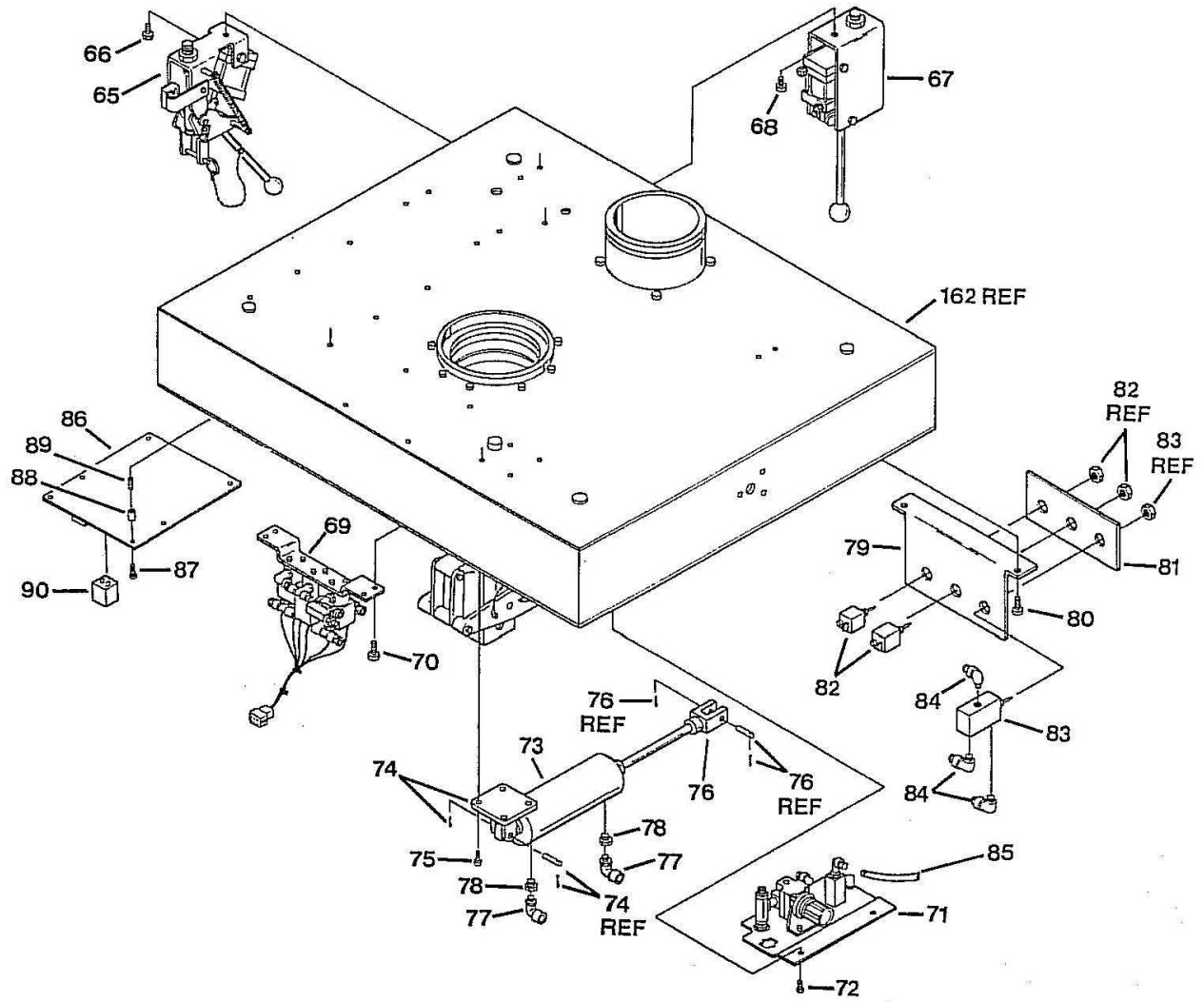

Figure 3-3. Roof Turret Assembly (Sheet 2).

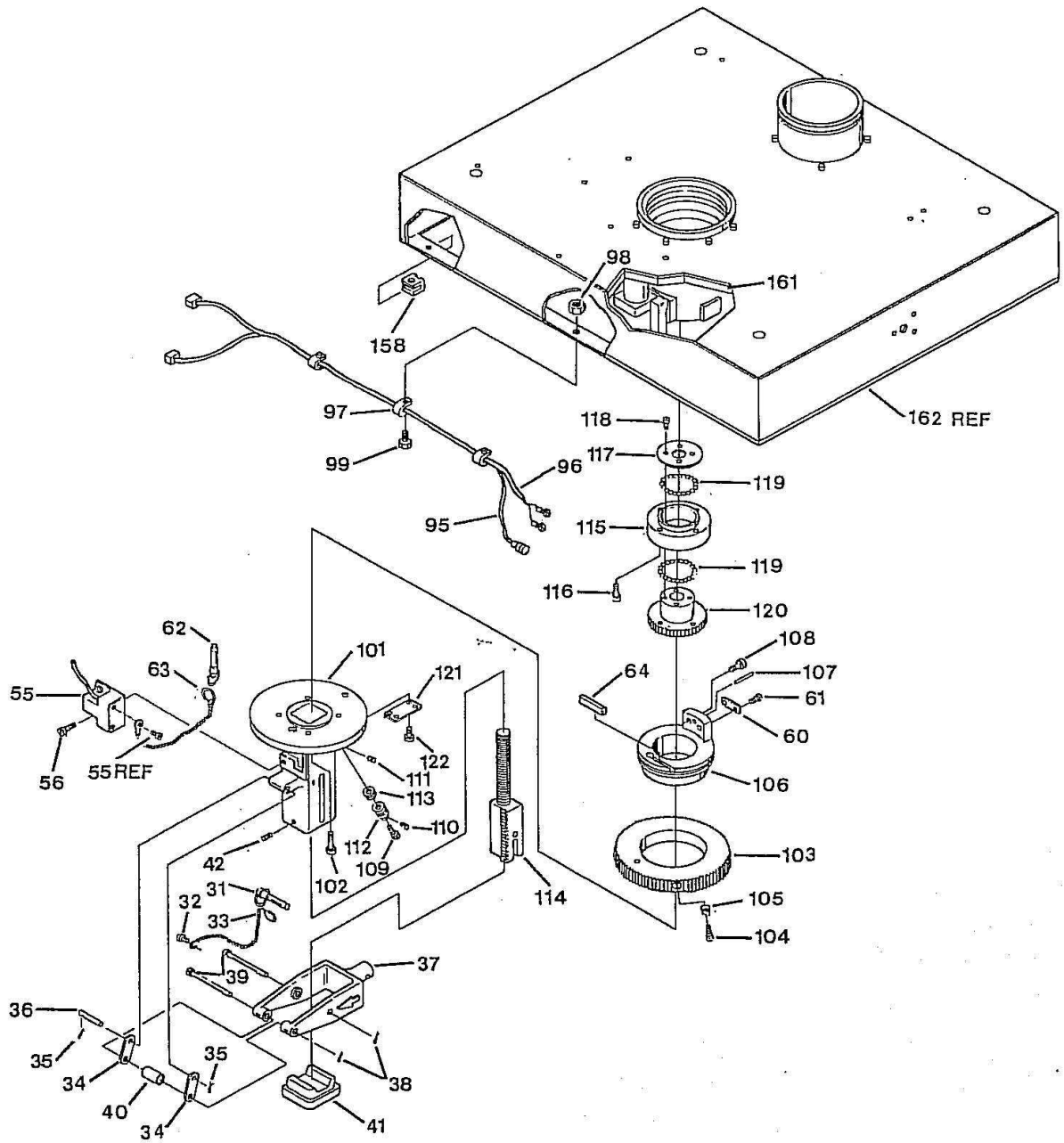

Figure 3-3. Roof Turret Assembly (Sheet 3).

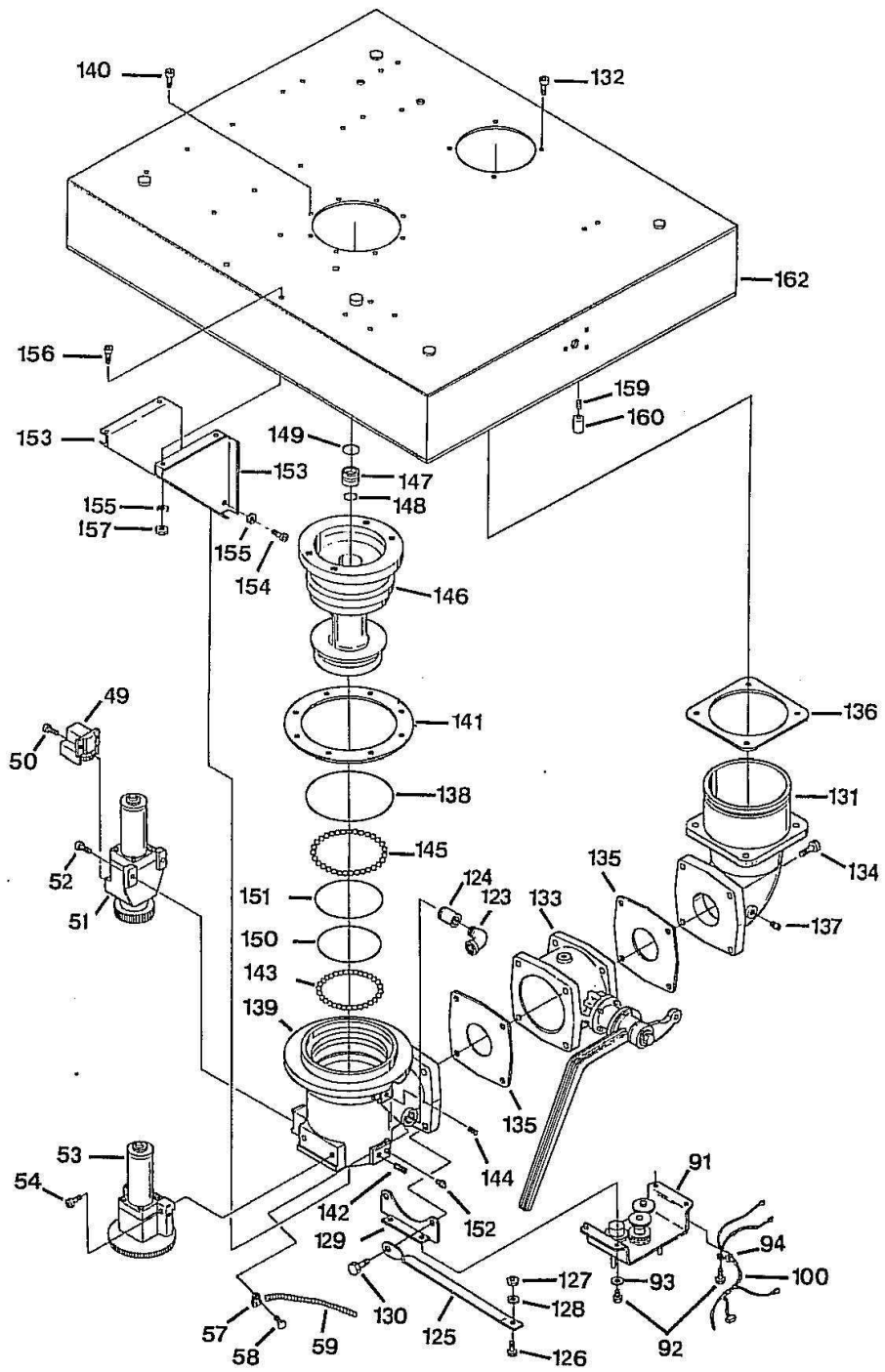

Figure 3-3. Roof Turret Assembly (Sheet 4).

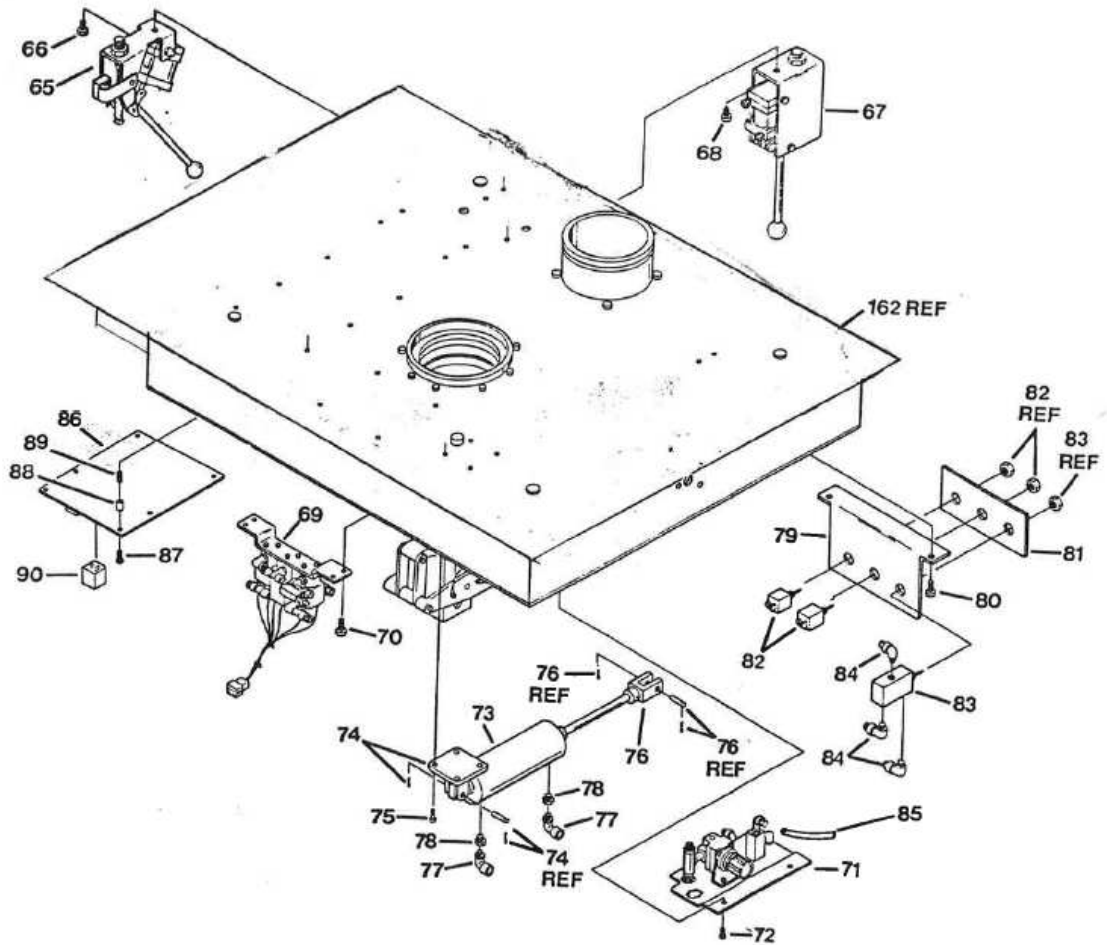

Figure 3-3. Roof Turret Assembly (Sheet 2).

Figure & Index Number	Part Number	Cage	Description	Units per Assy
3-3		00912	Roof Turret Assembly (see figure 3-2 for NHA)	REF
3-1	104509 (750/1500)	00912	Baffle Head	1
3-1	104512 (400/800)	00912	Baffle Head	1
3-1	104513 (600/1200)	00912	Baffle Head	1
3-1	104515 (375/750)	00912	Baffle Head	1
3-1	104517 (500/1000)	00912	Baffle Head	1
3-1	109429 (250/500)	00912	Baffle Head	1
3-2	7-67-117 768095 .003" 768096 .005" 768097 .010" 768098 .015"	00912	Screw Shim Shim Shim Shim	1 AR
3-3	7-07-284	00912	Clamp	1
3-4	7-66-036	00912	Screw	2
3-5	104540 (500/1000) (600/1200) (660/1320) (180/1500) (750/1500)	00912	Sleeve, Pattern	1
3-5	104541 (250/500) (300) (350) (375/750) (400/800) (500)	00912	Sleeve, Pattern	1
3-6	767140 (250/500) (500/1000) (300) (350) (500)	00912	Screw	1
3-6	769440 (375/750) (400/800) (600/1200) (660/1320) (180/1500) (750/1500)	00912	Screw	1
3-7	7-44-320	00912	Pin	1
3-8	7-07-304	00912	Clevis	1
3-9	7-29-144	00912	Upper Link	2
3-10	7-44-080	00912	Pin	4
3-11	7-45-088	00912	Pin	4
3-12	104548 (180/1500) (750/1500)	00912	Outlet Tee	1
3-12	104549 (500/1000) (600/1200) (660/1320)	00912	Outlet Tee	1
3-12	104550 (250/500) (375/750) (400/800) (300) (350) (500)	00912	Outlet Tee	1
3-13	7-04-340	00912	Bolt	1

3-14	7-57-055	00912	O-Ring	1
3-15	104510 (750/1500)	00912	Bracket	1
3-15	104514	00912	Bracket	1
3-16	7-60-040	00912	Screw	4
3-17	104542 (500/1000) (600/1200) (950/1200) (660/1320) (180/1500) (750/1500) (1200/1500)	00912	Baffle Stem	1
3-17	104543 (250/500) (375/750) (400/800) (500/1000) (300) (350) (475) (500)	00912	Baffle Stem	1
3-18	7-57-126	00912	O-Ring	1
3-19	104506 (750/1500)	00912	Bushing	1
3-19	104507 (500/1000) (600/1200)	00912	Bushing	1
3-20	757221 used with 104506 104507	00912	O-Ring	1
3-21	104535	00912	Nut	1
3-22	104547	00912	Tube	1
3-23	104534	00912	Nut	1
3-24	7-57-035	00912	O-Ring	2
3-25	7-57-225	00912	O-Ring	1
3-26	7-57-252	00912	O-Ring	1
3-25&26	7-57-346 use with 104550 only	00912	O-Ring	2
3-27	7-04-332	00912	Bracket	2
3-28	7-65-029	00912	Screw	6
3-29	7-07-276	00912	Cable Pattern	1
3-30	707-275	00912	Cable Rate	1
3-31	7-04-158	00912	Pin	1
3-32	7-61-041	00912	Screw	1
3-33	7-06-254	00912	Chain	1
3-34	7-29-143	00912	Link	2
3-35	7-44-168	00912	Pin	2
3-36	7-45-085	00912	Pin	1
3-37	104511	00912	Bracket	1
3-38	7-44-323	00912	Pin	2
3-39	7-45-097	00912	Pin	2
3-40	104545	00912	Spacer	1
3-41	7-04-333	00912	Bumper	1
3-42	7-44-049	00912	Pin	2
3-43	7-69-451	00912	Shaft	1
3-44	7-69-438	00912	Spring	3
3-45	104546	00912	Siamese	1
3-46	7-61-085	00912	Screw	4

3-47	7-57-225	00912	O-Ring	1
3-48	7-57-293	00912	O-Ring	1
3-49	34670005 104552 (manual bracket)	00912	Rotation Feedback Assembly(see figure 3-5 for details)	1
3-50	7-66-043 ¼-20 765120 (manual) 3/8-16	00912	Screw	2
3-51	34670034	00912	Rotation Gearbox Assembly (See figure 3-6 for details)	1
3-52	7-67-047	00912	Screw	2
3-53	34670033	00912	Elevation Gearbox assembly (see figure 3-7 for details)	1
3-54	7-65-120	00912	Screw	2
3-55	34670004	00912	Elevation feedback assembly (see figure 3-8 for details)	1
3-56	7-66-043	00912	Screw	2
3-57	7-07-189	00912	Clamp	1
3-58	7-65-104	00912	Screw	1
3-59	7-85-020	00912	Wrap	1
3-60	7-07-288	00912	Clamp	1
3-61	7-63-038	00912	Screw	2
3-62	7-04-158	00912	Pin	1
3-63	7-06-254	00912	Chain	1
3-64	7-07-286	00912	Cover	1
3-65	34670025 (W/spring assist) 34670028 (L/spring assist)	00912	Rate control assembly (see figure 3-9 for details)	1
3-66	7-66-043	00912	Screw	2
3-67	34670024	00912	Pattern control assembly(See figure 3-10 for details)	1
3-68	7-66-043	00912	Screw	1
3-69	34670069	00912	Solenoid valve assembly (see figure 3-11 for details)	1
3-70	7-66-043	00912	Screw	4
3-71	34670070	00912	Override valve assembly (see figure 3-12 for details)	1
3-72	7-63-037	00912	Screw	2
3-73	7-07-273	00912	Air Cylinder	1
3-74	7-69-435	00912	Bracket with pin and cotter pin	1
3-75	7-65-029	00912	Screw	4
3-76	7-07-279	00912	Clevis, with nut and pin	1
3-77	7-10-091	00912	Elbow	2
3-78	7-13-091	00912	Adapter	2
3-79	7-04-329	00912	Switch Bracket	1
3-80	7-63-037	00912	Screw	2
3-81	7-29-152	00912	Label	1
3-82	7-69-314	00912	Switch	2
3-83	7-79-064	00912	Valve	1
3-84	7-10-091	00912	Elbow	3
3-85	7-21-261	00912	Hose	1
3-86	7-04-570 12V	00912	Circuit Board	1
3-86	7-04-571 12V	00912	Circuit Board	1
3-86	7-04-572 24V	00912	Circuit Board	1

3-86	7-04-757 12V	00912	Circuit Board	1
3-87	7-61-041	00912	Screw	6
3-88	7-69-444	00912	Standoff	6
3-89	7-65-076	00912	Screw	6
3-90	7-58-141	00912	Relay	5
3-91	109168	00912	Oscillation limit control assembly	1
3-92	7-66-049	00912	Screw	4
3-93	7-84-072	00912	Washer	3
3-94	7-07-189	00912	Clamp	1
3-95	7-21-277	00912	Wiring harness	1
3-96	7-07-292 (type 1) 14-2	00912	Power cable	1
3-96	7-07-301 (type 2) 12-2	00912	Power cable	1
3-97	7-07-189	00912	Clamp	3
3-98	7-35-011	00912	Nut	3
3-99	7-63-037	00912	Screw	3
3-100	7-21-273	00912	Wiring harness	1
3-101	104551	00912	Yoke	1
3-102	7-66-036	00912	Screw	4
3-103	70005399	00912	Gear	1
3-104	7-65-029	00912	Screw	2
3-105	7-69-443	00912	Stop	2
3-106	104498	00912	Adapter	1
3-107	7-44-086	00912	Pin	1
3-108	7-65-157	00912	Screw	2
3-109	7-67-047	00912	Screw	1
3-110	7-65-042	00912	Screw	1
3-111	7-65-025	00912	screw	1
3-112	7-34-086	00912	Nut	1
3-113	7-69-276	00912	Spring	4
3-114	7-69-452	00912	Screw, elevation	1
3-115	104497	00912	Base, Siamese	1
3-116	7-66-036	00912	Screw	4
3-117	7-42-096	00912	Plate	1
3-118	7-65-028	00912	Screw	4
3-119	7-04-018	00912	Ball bearing	78
3-120	7005322	00912	Nut, gear	1
3-121	7-44-321	00912	ID plate	1
3-122	7-36-045	00912	Nail	4
3-123	7-10-093	00912	Elbow	1
3-124	34670001	00912	Drain valve assembly (see figure 3-13 for details)	1
3-125	7-69-439	00912	Strap	2
3-126	7-67-130	00912	Screw	2
3-127	7-34-082	00912	Nut	2
3-128	7-84-090	00912	Washer	2
3-129	7-04-320	00912	Bracket	2
3-130	7-61-086	00912	Screw	4
3-131	104530	00912	Inlet	1
3-132	7-67-047	00912	Screw	4
3-133	34670068	00912	Three inch valve assembly (see figure 3-14 for details)	1
3-134	7-61-058	00912	Screw	4
3-135	7-16-044	00912	Gasket	2

3-136	7-16-043	00912	Gasket	1
3-137	7-44-011	00912	Plug	1
3-138	7-57-294	00912	O-ring	1
3-139	104518	00912	Elbow	1
3-140	7-66-036	00912	Screw	8
3-141	7-16-045	00912	Gasket	1
3-142	7-42-024	00912	Plug	1
3-143	7-04-020	00912	Ball bearing	36
3-144	7-42-024	00912	Plug	1
3-145	7-04-020	00912	Ball bearing	41
3-146	104503	00912	Base, Siamese	1
3-147	104505	00912	Bushing	1
3-148	7-57-054	00912	O-ring	1
3-149	7-57-293	00912	O-ring	1
3-150	7-57-068	00912	O-ring	1
3-151	7-57-078	00912	O-ring	1
3-152	7-13-191	00912	Fitting	2
3-153	7-04-331 (type1) 7-06-017 (type2)	00912	Bracket clamp	2 2
3-154	7-65-160 (type1) 7-21-043 (type2)	00912	Screw Hose	2 1
3-155	7-84-081 (type1) 7-13-097 (type2)	00912	Washer Fitting	6 1
3-156	7-36-072 (type1) 7-13-098 (type2)	00912	Screw Union	4 1
3-157	7-34-079 (type1) 7-44-322 (type2)	00912	Nut Plug	4 1
3-158	7-69-433 (type1) 7-58/198 (type2)	00912	Clip Receptacle	14
3-159	7-65-084 (type1) 7-65-076 (type2)	00912	Screw Screw	2 6
3-160	7-69-445 (type1) 7-69-444 (type2)	00912	Standoff Standoff	2 6
3-161	7-23-017 (type1) 7-23-018 (type2)	00912	Insulation Insulation	1 1
3-162	70005719 (type1) 744414	00912	Plate Plate	1 1
	91970001	00912	Parts kit, general turret seal, assortment	AR

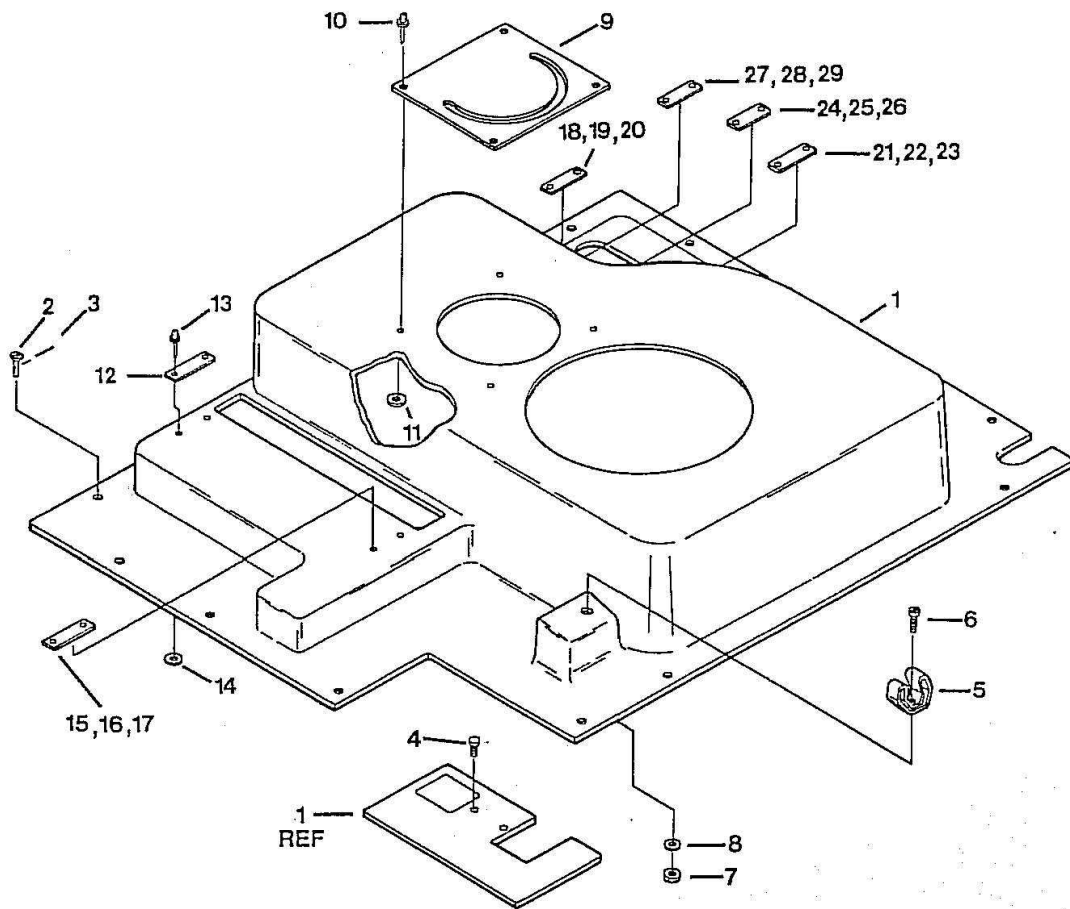

Figure 3-4. False Ceiling.

Figure & Index Number	Part Number	Cage	Description	Units per Assy
3-4	34670083 (type1) 34670048 (type2)	00912	False Ceiling (see figure 3-2 for NHA)	REF
3-1	7-07-278	00912	Ceiling	1
3-2	7-69-431	00912	Stud	14
3-3	7-69-432	00912	Retainer	14
3-4	7-63-056	00912	Screw	2
3-5	7-07-282	00912	Clip	1
3-6	7-63-022	00912	Screw	1
3-7	7-35-017	00912	Nut	1
3-8	7-84-098	00912	Washer	2
3-9	7-42-097	00912	Cover	1
3-10	7-54-055	00912	Rivet	4
3-11	7-84-101	00912	Washer	4
3-12	7-29-145	00912	Label, valve Open	1
3-13	7-54-054	00912	Rivet	2
3-14	7-84-101	00912	Washer	2
3-15	7-29-146	00912	Label, valve closed	1
3-16	7-54-054	00912	Rivet	2
3-17	7-84-101	00912	Washer	2
3-18	7-29-148	00912	Label, low flow	1
3-19	7-54-054	00912	Rivet	2
3-20	7-84-101	00912	Washer	2
3-21	7-29-149	00912	Label, High flow	1
3-22	7-54-054	00912	Rivet	2
3-23	7-84-101	00912	Washer	2
3-24	7-29-151	00912	Label, dispersed	1
3-25	7-54-054	00912	Rivet	2
3-26	7-84-101	00912	Washer	2
3-27	7-29-151	00912	Label, solid stream	1
3-28	7-54-054	00912	Rivet	2
3-29	7-84-101	00912	Washer	2
	91990001	00912	Parts kit, headliner label	AR

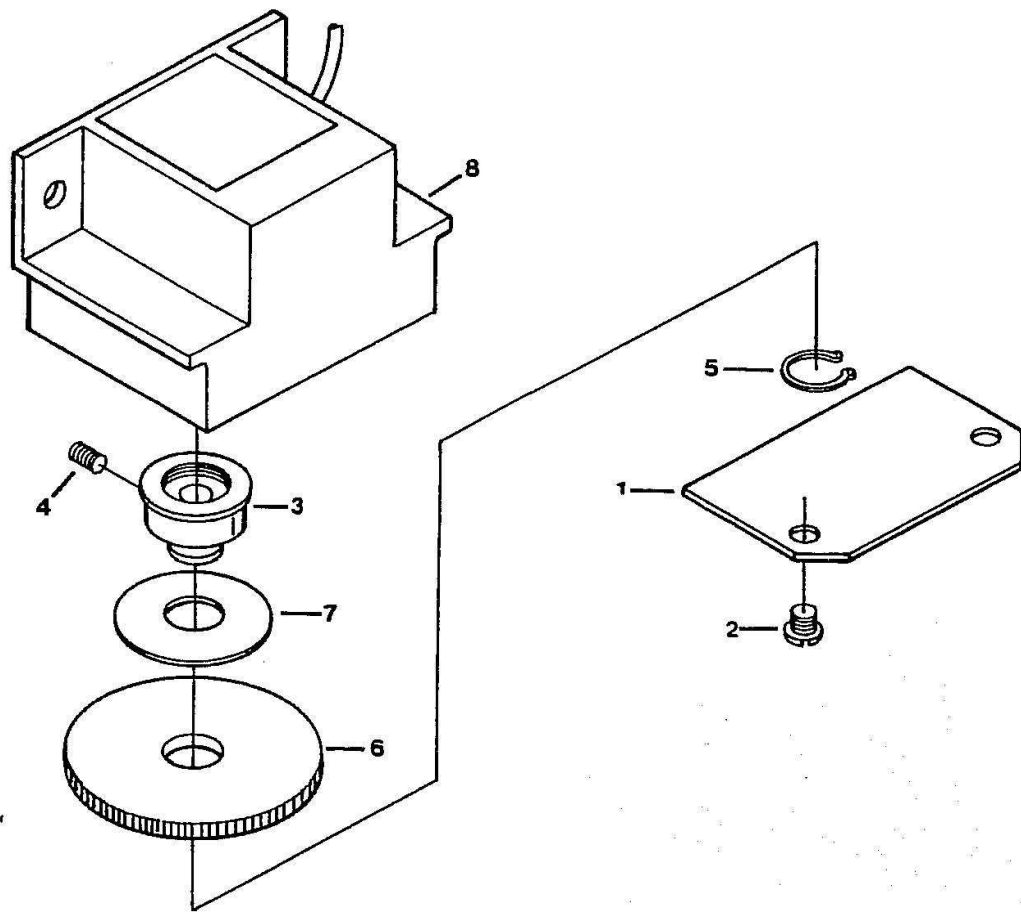

Figure 3-5. Rotation Feedback Assembly.

Figure & Index Number	Part Number	Cage	Description	Units per Assy
3-5	34670005	00912	Rotation feedback assembly (see figure 3-3 for NHA)	REF
3-1	7-07-283	00912	Cover	1
3-2	7-61-041	00912	Screw	2
3-3	40047301	00912	Hub	1
3-4	7-65-042	00912	Screw	1
3-5	7-58-149	00912	Ring	1
3-6	7-18-144	00912	Gear	1
3-7	7-68-199	00912	Washer	1
3-8	7005559	00912	Pot, subassembly	1

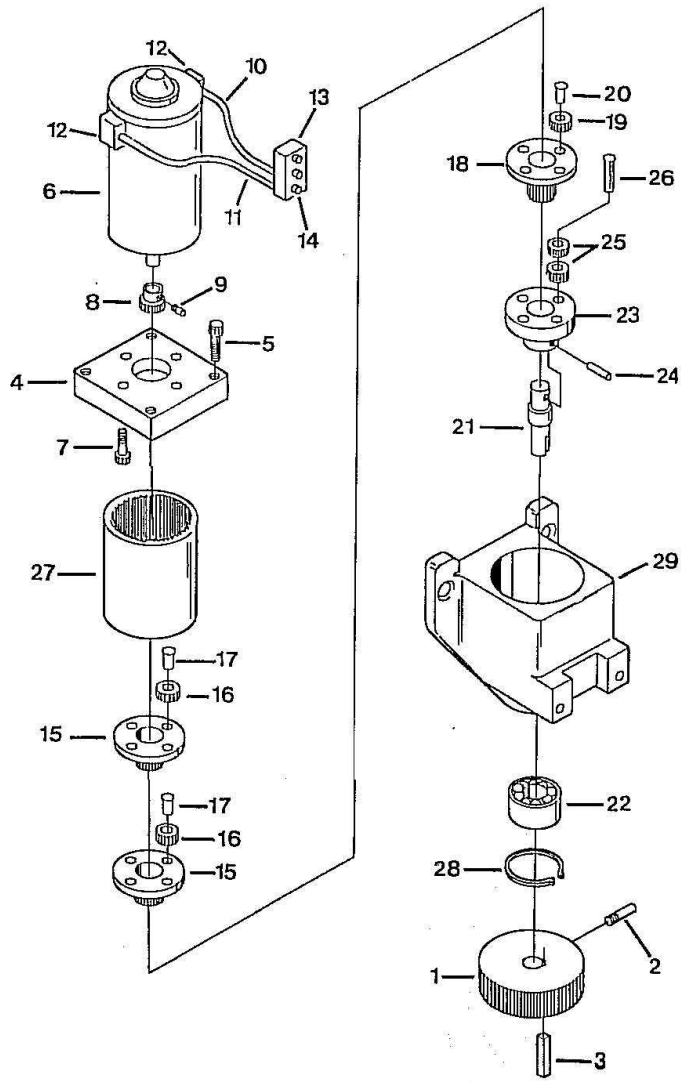

Figure3-6. Rotation Gearbox Assembly.

Figure & Index Number	Part Number	Cage	Description	Units per Assy
3-6	34670034	00912	Rotation Gearbox Assembly (see figure 3-3 for NHA)	REF
3-1	7-18-149	00912	Gear	1
3-2	7-65-084	00912	Screw	2
3-3	7-27-038	00912	Key	1
3-4	104499	00912	Adapter	1
3-5	7-67-100	00912	Screw	4
3-6	7-31-057	00912	Motor	1
3-7	7-65-052	00912	Screw	4
3-8	7-18-148	00912	Gear	1
3-9	7-65-082	00912	Screw	2
3-10	7-83-037	00912	Wire, black	1
3-11	7-83-036	00912	Wire, red	1
3-12	7-07-302	00912	Connector	2
3-13	7-07-294	00912	Housing	1
3-14	7-07-296	00912	Pin	2
3-15	7-45-074	00912	Plate	2
3-16	7-18-136	00912	Gear	8
3-17	7-54-052	00912	Rivet	12
3-18	7-45-075	00912	Plate	1
3-19	7-18-136	00912	Gear	4
3-20	7-54-052	00912	Rivet	4
3-21	7-69-447	00912	Shaft	1
3-22	7-04-313	00912	Bearing	1
3-23	7-07-287	00912	Carrier	1
3-24	7-44-208	00912	Pin	1
3-25	7-18-136	00912	Gear	8
3-26	7-54-051	00912	Rivet	4
3-27	7-18-135	00912	Gear	1
3-28	7-58-196	00912	Ring	1
3-29	104526	00912	Housing	1

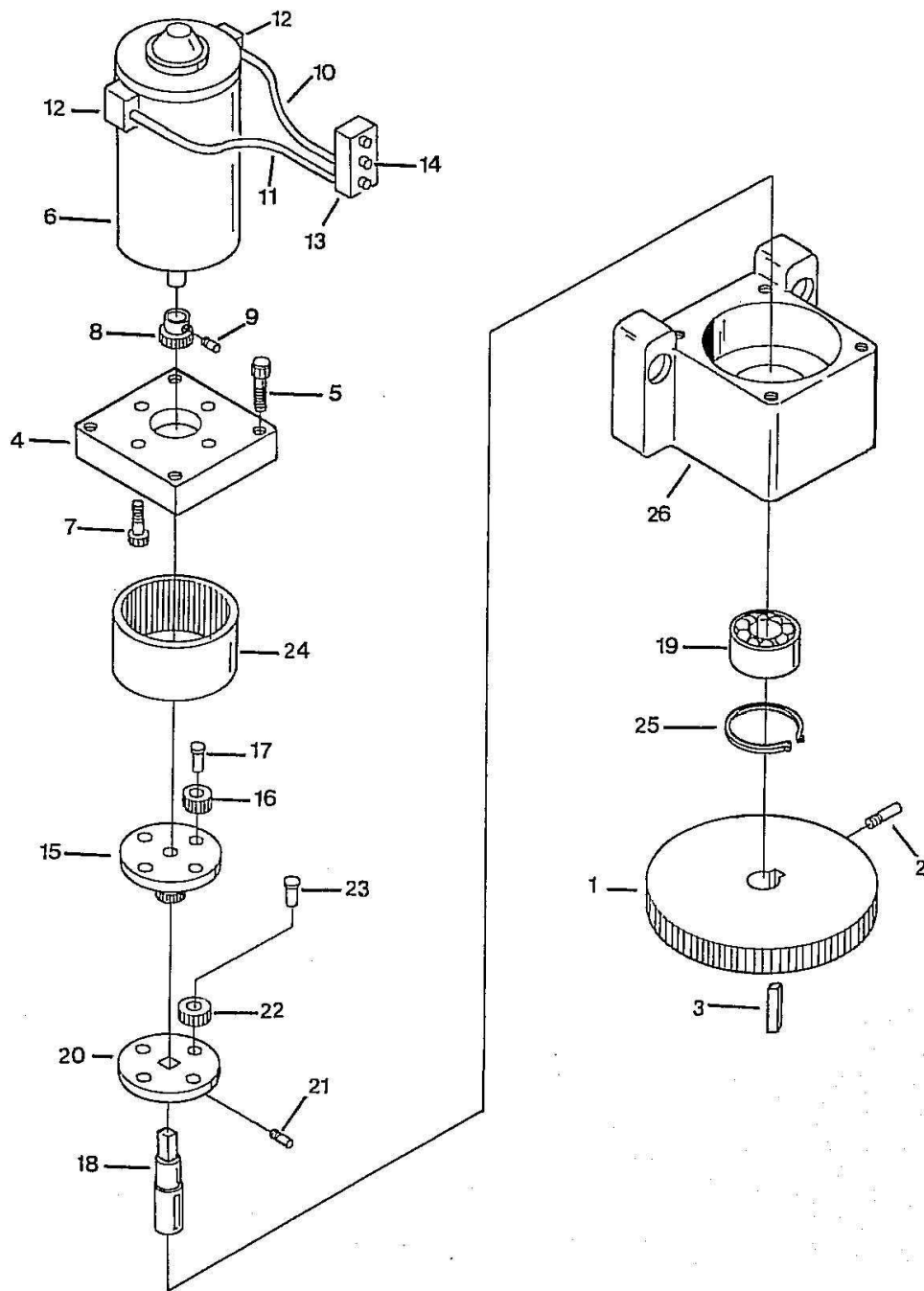

Figure 3-7. Elevation Gearbox Assembly.

Figure & Index Number	Part Number	Cage	Description	Units per Assy
3-7	34670033	00912	Rotation Gearbox Assembly (see figure 3-3 for NHA)	REF
3-1	7-18-150	00912	Gear	1
3-2	7-65-084	00912	Screw	2
3-3	7-27-038	00912	Key	1
3-4	104499	00912	Adapter	1
3-5	7-67-100	00912	Screw	4
3-6	7-31-057	00912	Motor	1
3-7	7-65-052	00912	Screw	4
3-8	7-18-148	00912	Gear	1
3-9	7-65-082	00912	Screw	2
3-10	7-83-037	00912	Wire, black	1
3-11	7-83-036	00912	Wire, red	1
3-12	7-07-302	00912	Connector	2
3-13	7-07-294	00912	Housing	1
3-14	7-07-296	00912	Pin	2
3-15	7-45-074	00912	Plate	1
3-16	7-18-136	00912	Gear	4
3-17	7-54-052	00912	Rivet	4
3-18	7-69-448	00912	Shaft	1
3-19	7-04-313	00912	Bearing	1
3-20	7-07-289	00912	Carrier	1
3-21	7-44-208	00912	Pin	1
3-22	7-18-136	00912	Gear	4
3-23	7-54-052	00912	Rivet	4
3-24	7-18-147	00912	Gear	1
3-25	7-58-196	00912	Ring	1
3-26	104527	00912	Housing	1

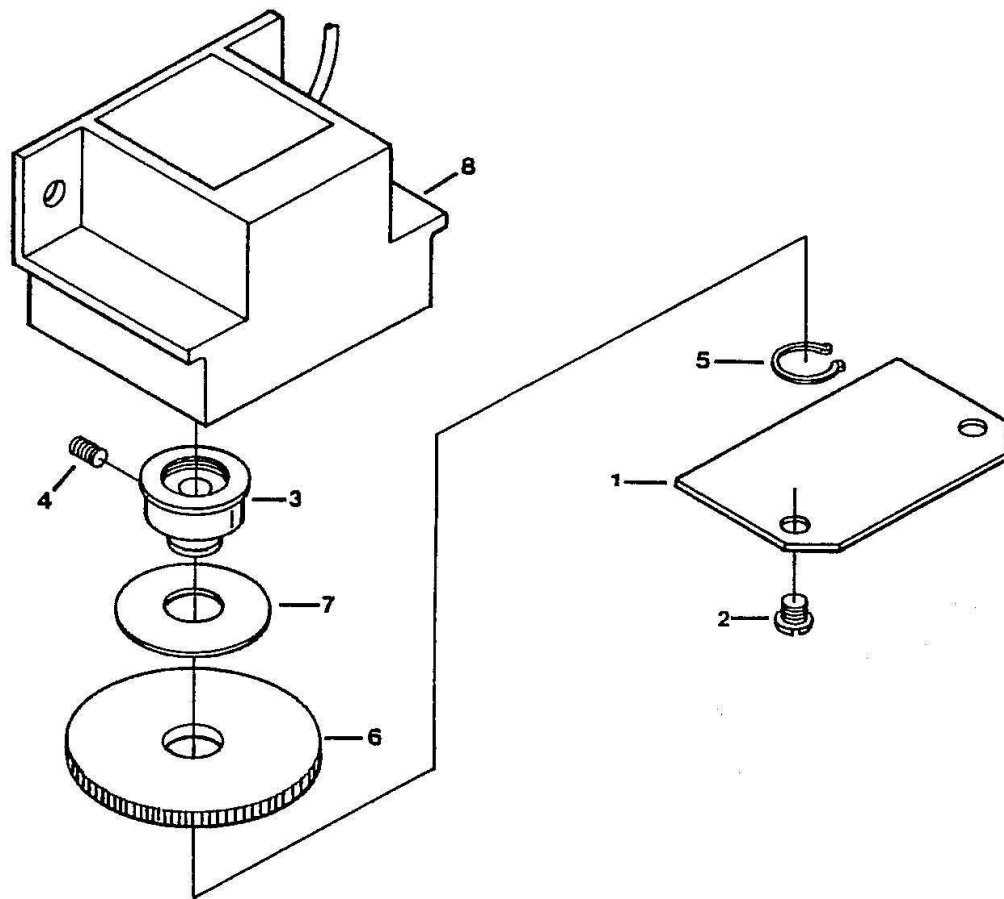

Figure 3-8. Elevation Feedback Assembly.

Figure & Index Number	Part Number	Cage	Description	Units per Assy
3-8	34670004	00912	Elevation feedback assembly (See figure 3-3 for NHA)	REF
3-1	7-07-283	00912	Cover	1
3-2	7-61-041	00912	Screw	2
3-3	40047301	00912	Hub	1
3-4	7-65-042	00912	Screw	1
3-5	7-58-149	00912	Ring	1
3-6	7-18-144	00912	Gear	1
3-7	7-68-199	00912	Washer	1
3-8	70005560	00912	Pot subassembly	1

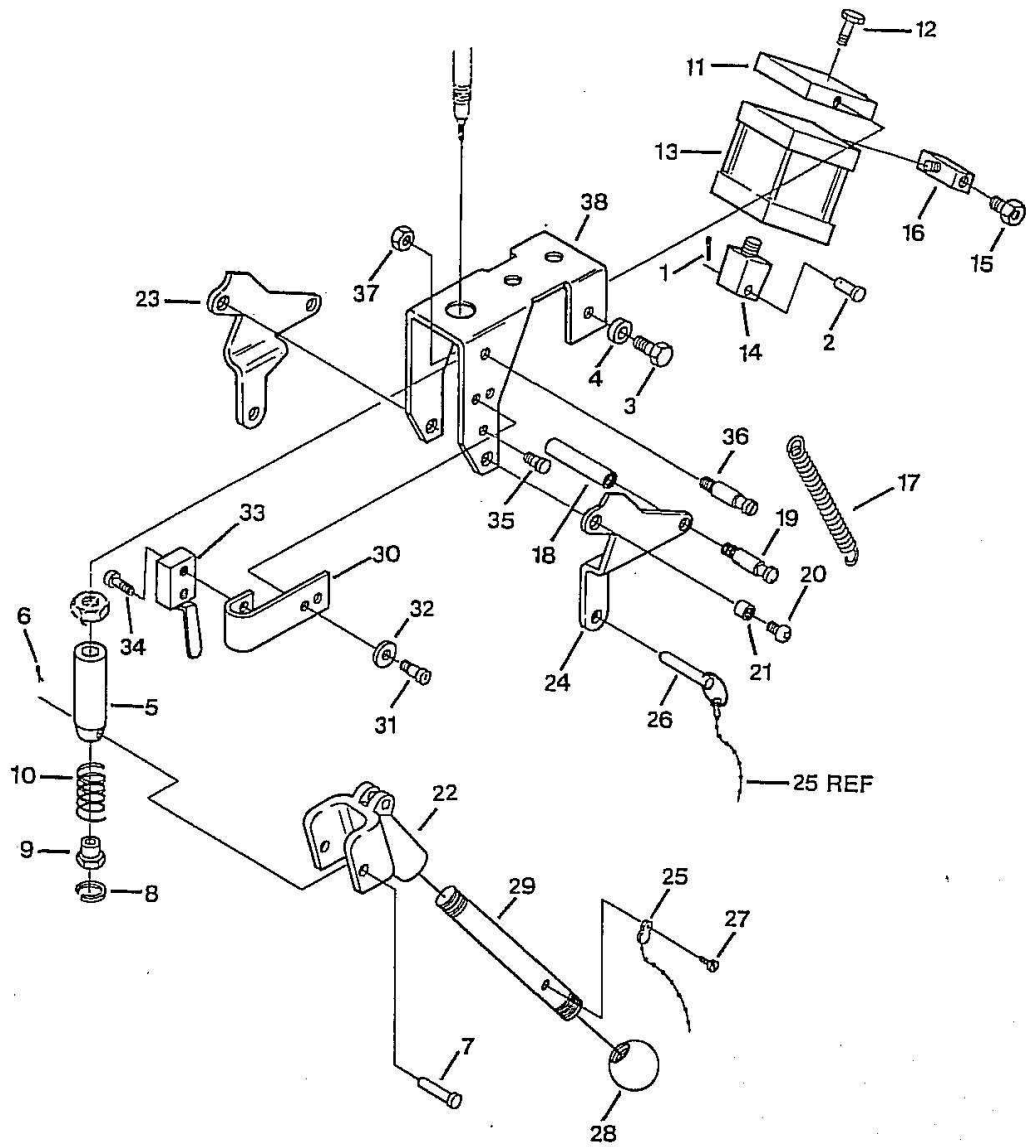

Figure 3-9. Rate Control Assembly.

Figure & Index Number	Part Number	Cage	Description	Units per Assy
3-9	34670025 (W/spring) 34670028 (L/spring)	00912	Rate Control assembly (see figure 3-3 for NHA)	REF
3-1	7-44-317	00912	Pin	1
3-2	7-44-318	00912	Pin	1
3-3	3-61-050	00912	Screw	2
3-4	7-07-285	00912	Collar	2
3-5	104523	00912	Housing	1
3-6	7-44-317	00912	Pin	1
3-7	7-44-316	00912	Pin	1
3-8	7-58-128	00912	Ring	1
3-9	104532	00912	Nut	1
3-10	7-69-436	00912	Spring	1
3-11	104508	00912	Block	1
3-12	7-65-144	00912	Screw	2
3-13	7-07-274	00912	Cylinder	1
3-14	7-45-091	00912	Rod	1
3-15	7-13-082	00912	Fitting	2
3-16	7-79-065	00912	Valve	2
3-17	7-69-456 (type1) 7-63-056 (type2)	00912	Spring Screw	2 2
3-18	7-69-449 (type1) 104528 (type2)	00912	Standoff Hub	1 1
3-19	7-45-093 (type1) 7-03-080 (type2)	00912	Pivot, spring Ball	2 1
3-20	7-65-059 (type1) 70005786 (type2)	00912	Screw Rod	2 1
3-21	7-07-297 (type1) 7-04-323 (type2)	00912	Collar Bracket	2 1
3-22	104524 (type1) 7-65-027 (type2)	00912	Hub Screw	1 2
3-23	7-29-154 (type1) 7-84-102 (type2)	00912	Link, right Washer	1 2
3-24	7-29-155 (type1) 7-69-430 (type2)	00912	Link, left Switch	1 1
3-25	7-06-254 (type1) 7-67-094 (type2)	00912	Chain Screw	1 2
3-26	7-45-094 (type1) 7-04-326 (type2)	00912	Pin Bracket	1 1
3-27	7-61-041	00912	Screw	1
3-28	7-03-080	00912	Ball	1
3-29	70005593	00912	Rod	1
3-30	7-04-323	00912	Bracket	1
3-31	7-65-027	00912	Screw	2
3-32	7-84-102	00912	Washer	2
3-33	7-69-430	00912	Switch	1
3-34	7-67-094	00912	Screw	2
3-35	7-65-131	00912	Screw	2
3-36	7-45-093	00912	Pivot, spring	2
3-37	7-34-061	00912	Nut	2
3-38	7-04-326	00912	Bracket	1

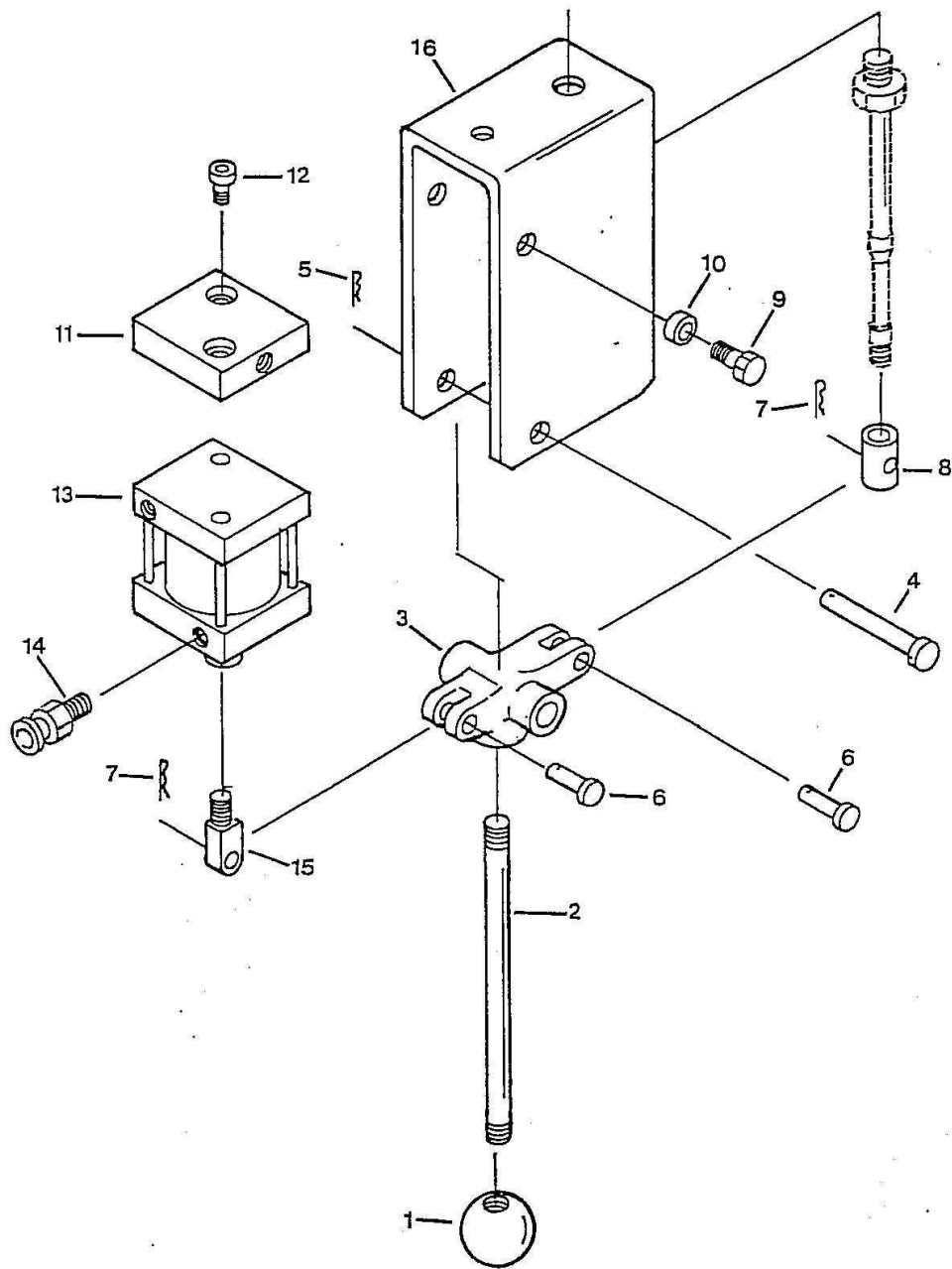

Figure 3-10. Pattern Control Assembly.

Figure & Index Number	Part Number	Cage	Description	Units per Assy
3-10	34670024	00912	Pattern control assembly (See figure 3-3 for NHA)	REF
3-1	7-03-080	00912	Ball	1
3-2	70005786	00912	Rod	1
3-3	104525	00912	Hub	1
3-4	7-44-319	00912	Pin	1
3-5	7-44-317	00912	Pin	1
3-6	7-44-318	00912	Pin	2
3-7	7-44-317	00912	Pin	2
3-8	104519	00912	Fitting	1
3-9	7-61-050	00912	Screw	2
3-10	7-07-285	00912	Collar	2
3-11	104508	00912	Block	1
3-12	7-65-144	00912	Screw	2
3-13	7-07-277	00912	Cylinder	1
3-14	7-13-082	00912	Fitting	2
3-15	7-45-091	00912	Rod	1
3-16	7-04-327	00912	Bracket	1

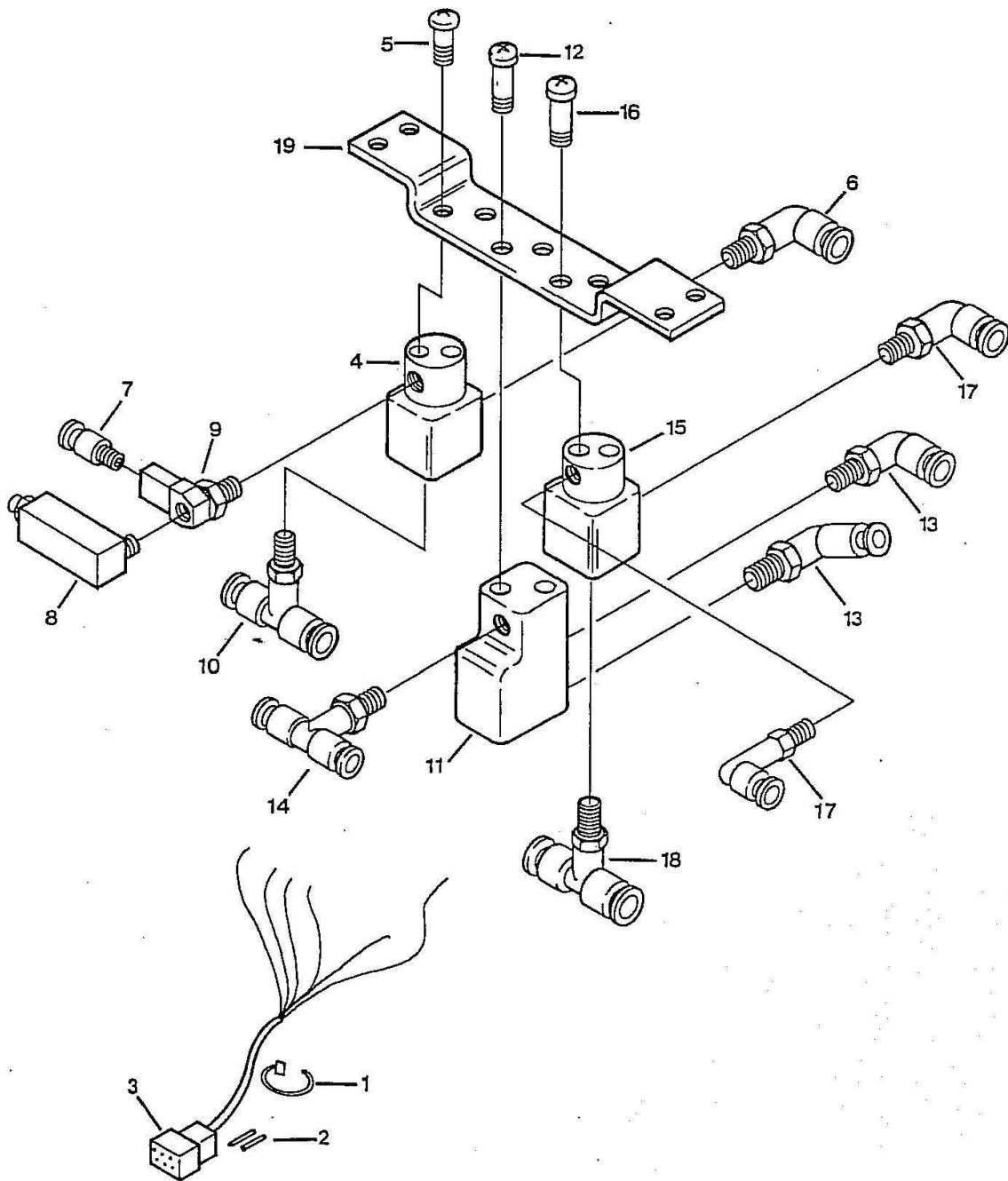

Figure 3-11. Solenoid Valve Assembly

Figure & Index Number	Part Number	Cage	Description	Units per Assy
3-11	34670069	00912	Solenoid valve assembly (see figure 3-3 for NHA)	REF
3-1	7-72-143	00912	Tie wrap	14
3-2	7-07-296	00912	Pin	6
3-3	7-07-295	00912	Housing	1
3-4	7-79-061	00912	Valve 3-way	1
3-5	7-65-152	00912	Screw	2
3-6	7-10-091	00912	Elbow	1
3-7	7-13-082	00912	Fitting	1
3-8	7-79-065	00912	Valve	1
3-9	7-13-084	00912	Fitting	1
3-10	7-13-093	00912	Tee	1
3-11	7-79-062	00912	Valve	1
3-12	7-65-152	00912	Screw	2
3-13	7-10-091	00912	Elbow	2
3-14	7-13-093	00912	Tee	1
3-15	7-79-061	00912	Valve, 3 way	1
3-16	7-65-152	00912	Screw	2
3-17	7-10-091	00912	Elbow	2
3-18	7-13-093	00912	Tee	1
3-19	7-04-322	00912	Bracket	1

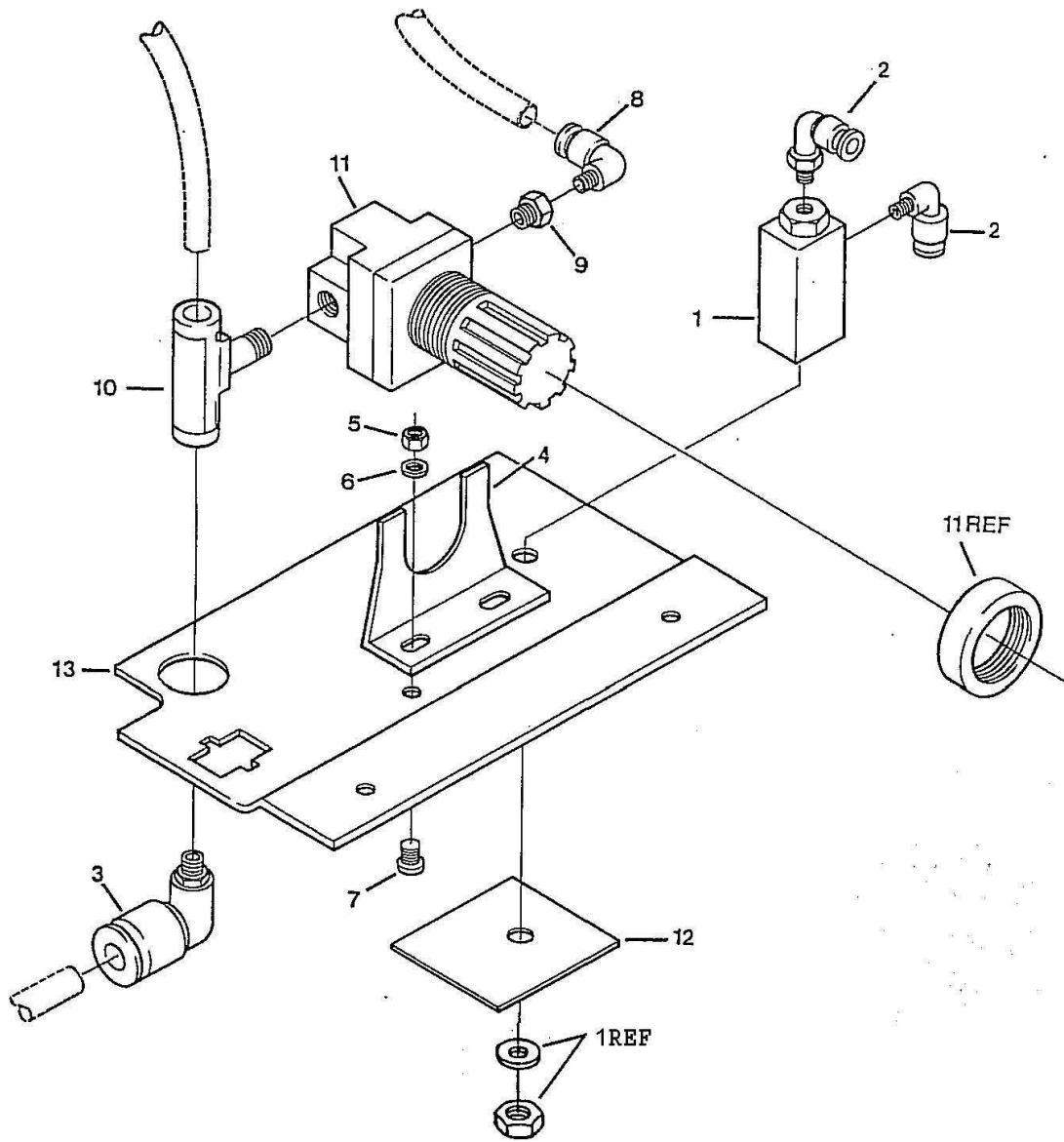

Figure 3-12. Override Valve Assembly.

Figure & Index Number	Part Number	Cage	Description	Units per Assy
3-12	34670070	00912	Override valve assembly (see figure 3-3 for NHA)	REF
3-1	7-79-063	00912	Valve	1
3-2	7-10-091	00912	Elbow	2
3-3	7-13-092	00912	Fitting	1
3-4	7-04-306	00912	Bracket	1
3-5	7-35-011	00912	Nut	2
3-6	7-84-072	00912	Washer	2
3-7	7-63-037	00912	Screw	2
3-8	7-10-091	00912	Elbow	1
3-9	7-13-091	00912	Fitting	1
3-10	7-13-094	00912	Fitting	1
3-11	7-58-195	00912	Regulator	1
3-12	7-29-147	00912	Label	1
3-13	7-04-330	00912	Bracket	1

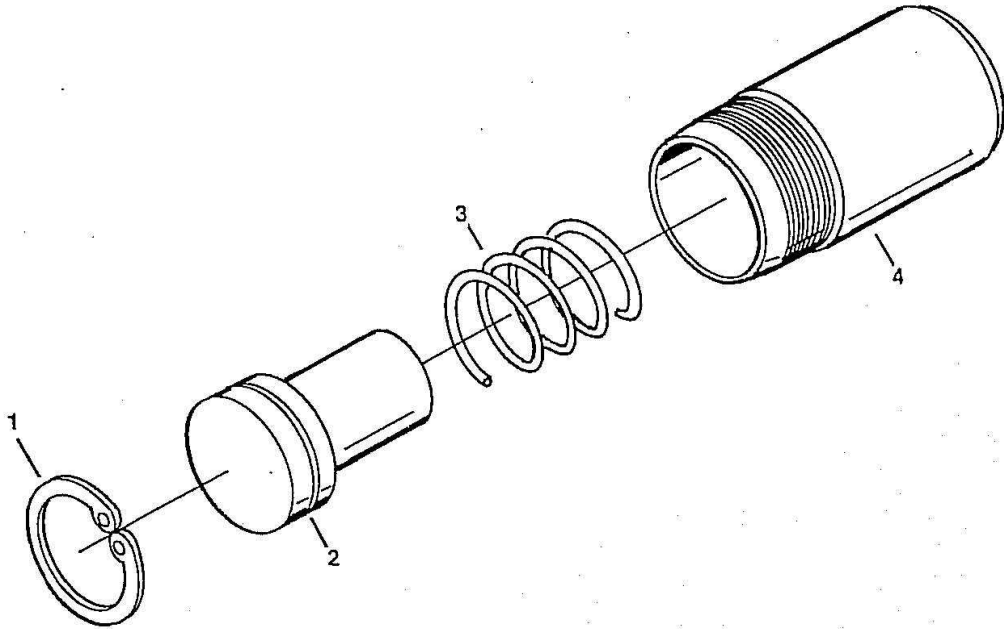

Figure 3-13. Drain Valve Assembly.

Figure & Index Number	Part Number	Cage	Description	Units per Assy
3-13	34670001	00912	Drain Valve assembly (see figure 3-3 for NHA)	REF
3-1	7-58-127	00912	Ring	1
3-2	7-45-087	00912	Poppet	1
3-3	7-69-437	00912	Spring	1
3-4	7-04-319	00912	body	1

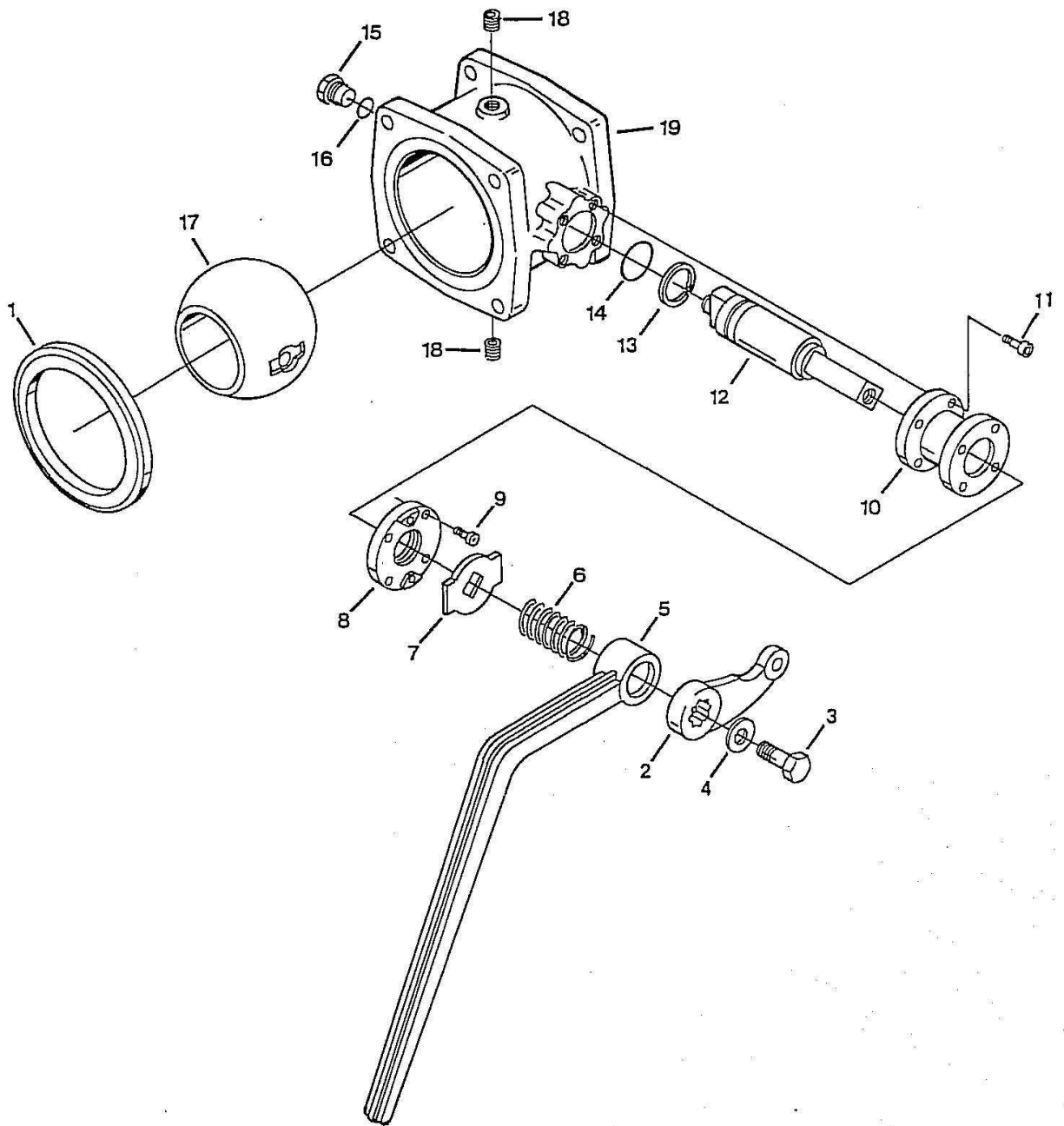
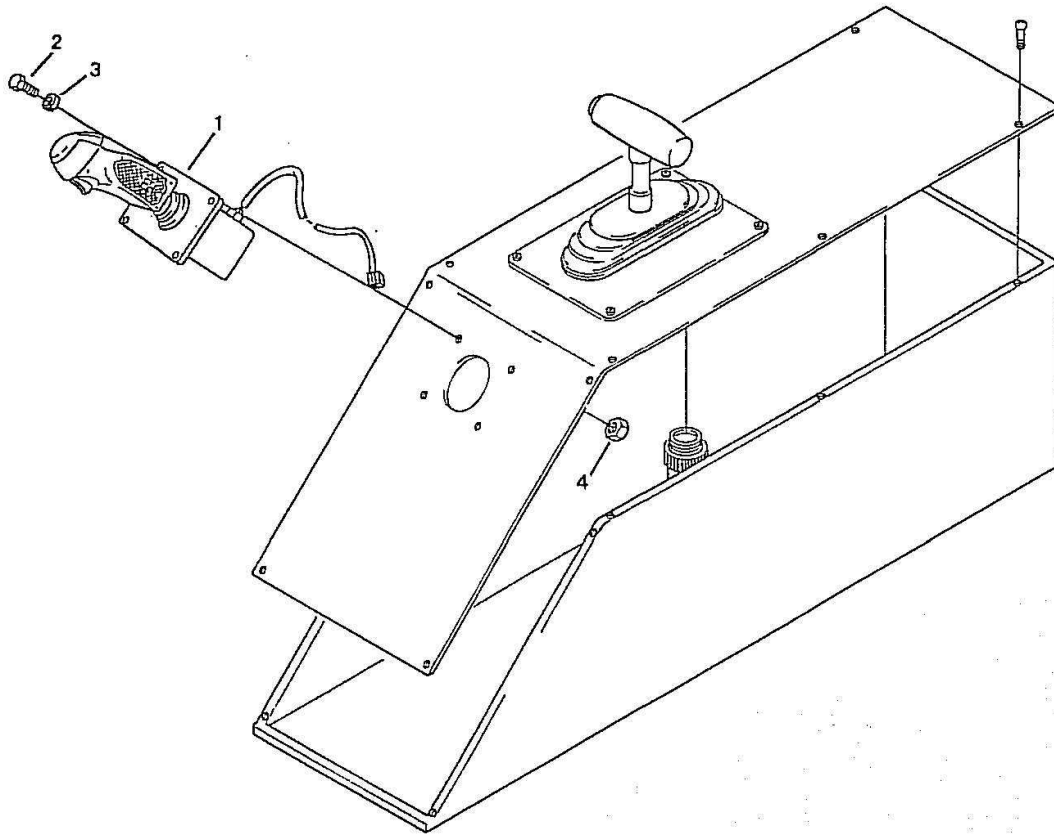

Figure 3-14. Three Inch Valve Assembly.

Figure & Index Number	Part Number	Cage	Description	Units per Assy
3-14	34670068	00912	Three inch valve assembly (see figure 3-3 for NHA)	REF
3-1	7-69-181	00912	Seat	2
3-2	104502	00912	Arm	1
3-3	7-61-065	00912	Screw	1
3-4	7-84-034	00912	Washer	1
3-5	104522	00912	Handle	1
3-6	7-68-235	00912	Spring	1
3-7	7-42-092	00912	Plate	1
3-8	7-42-089	00912	Plate	1
3-9	7-65-028	00912	Screw	4
3-10	7-21-275	00912	Housing	1
3-11	7-67-086	00912	Screw	4
3-12	7-72-145	00912	Trunnion	1
3-13	7-58-154	00912	Ring	1
3-14	7-57-010	00912	O-ring	1
3-15	7-73-095	00912	Trunnion	1
3-16	7-57-217	00912	O-ring	1
3-17	116320	00912	Ball	1
3-18	7-44-011	00912	Plug	3
3-19	40008773	00912	Body	1
	91980001	00912	Parts kit valve seat (contains gasket, figure 3-3 index –135)	AR



3-15. Joystick Installation.

Figure & Index Number	Part Number	Cage	Description	Units per Assy
3-15	No Number	00912	Joystick Installation (See figure 3-2 for NHA)	REF
3-1	34670002 (type1) 34670003 (type2)	00912	Joystick Assembly	1
3-2	602474 (type1) 7-29-156 (type2)	00912	Bolt Label	4 1
3-3	600619 (type1) 7-29-157 (type2)	00912	Washer Label	4 1
3-4	602184 (type1) 7-42-100 (type2)	00912	Nut Plate	4 1
3-5	7-63-067 (type2)	00912	Screw	4
3-6	109198 (type2)	00912	Housing	1
3-7	109197 (type2)	00912	Cover	1
3-8	7-63-061 (type2)	00912	Screw	4

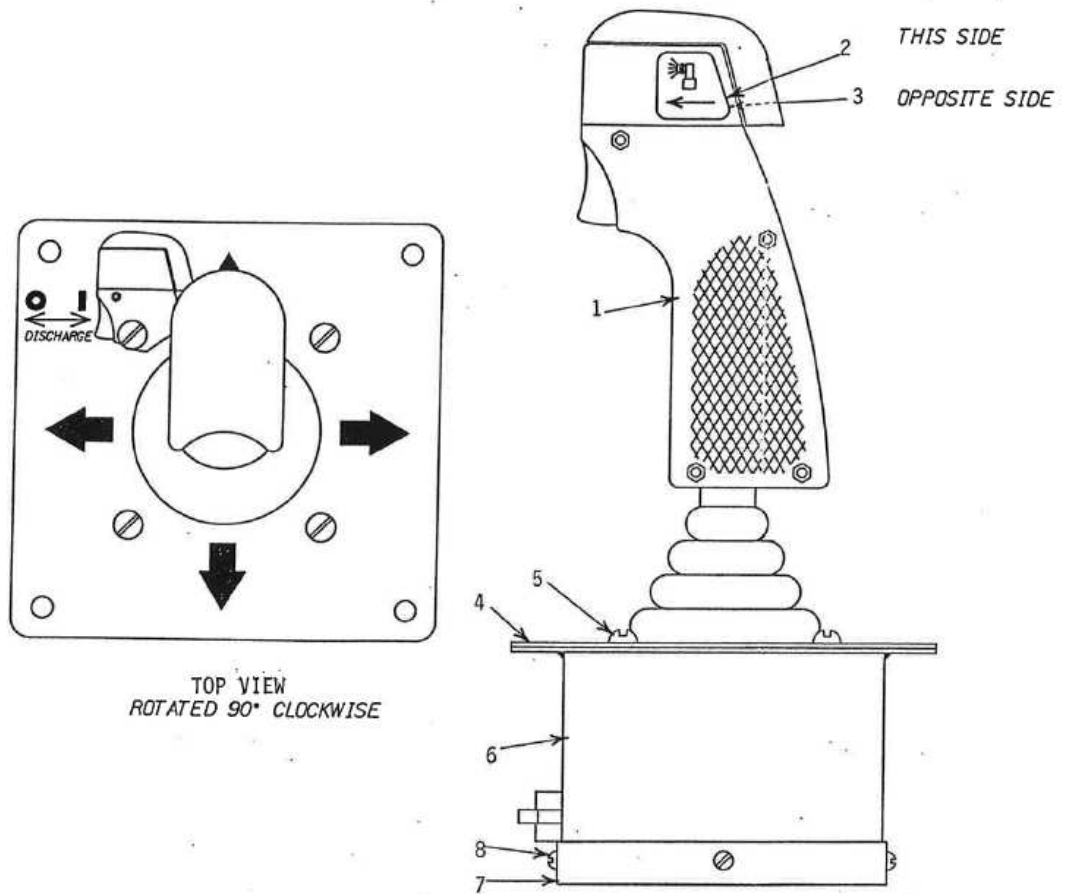

FIGURE 3-15 JOYSTICK ASSEMBLY

Appendix A
EXPENDABLE SUPPLIES AND MATERIALS LIST

A-1. Scope. This appendix lists expendable supplies and materials needed to maintain and repair the roof turret.

A-2. Explanation of Columns

Column 1 – Item Number. This number is assigned to each entry in the list and is referenced in the narrative instructions.

Column 2 – Description. Indicates the federal item name and, if required, a description to help identify the item. Commercial names or descriptions are used if no federal item name is available.

Column 3 – National Stock Number. This column lists the national stock number, if available. Use it to request or requisition the item.

(1) Item Number	(2) Description	(3) National Stock Number
1	Grease, Silicone	
2	Loctite 222	
3	Loctite 277 mil-s-46163	
4	Lubriplate, 130 AA	
5	Oil, lubricating, gear mil-2105 go-85/140 1-qt. Can 5-gal. Container 55-gal. Drum Oil, Lubricating, Gear mil-1-2105 go-75 1-qt. Can 5-gal. Container 55-gal. Drum	
6	Polyurethane sealant Silkaflex-1a, fed-spec TT-S- 00230C type II Class A, Sika Corporation	
7	Sealant, Permalok lh050	
8	Lubricant, rust preventive	
9	Solvent, dry cleaning, sd2, fed. Spec. p-d-680 Type II 1-qt. Can 1-gal. Can 5-gal. Container 55-gal Drum	6850-00-664-5685 6850-00-281-1985 6850-00-274-5421 6850-00-281-1986
10	Cleaner, Sikkens M600	
11	Sealant, silicone RTV mil- a46106, Type I (black), 5-oz. Tube	5330-01-052-5759
12	Loctite 680	
13	Adhesive, latex, for insulation MACCO Adhesives, the Glidden Co., Cleveland, OH 44115 Product no. 0600413	

Appendix B
ELECTRICAL SCHEMATICS

B-1. General. Appendix B contains schematic drawings which identify the electrical components and wiring circuit on the roof turret. Refer to these drawings when trouble- shooting the electrical system.

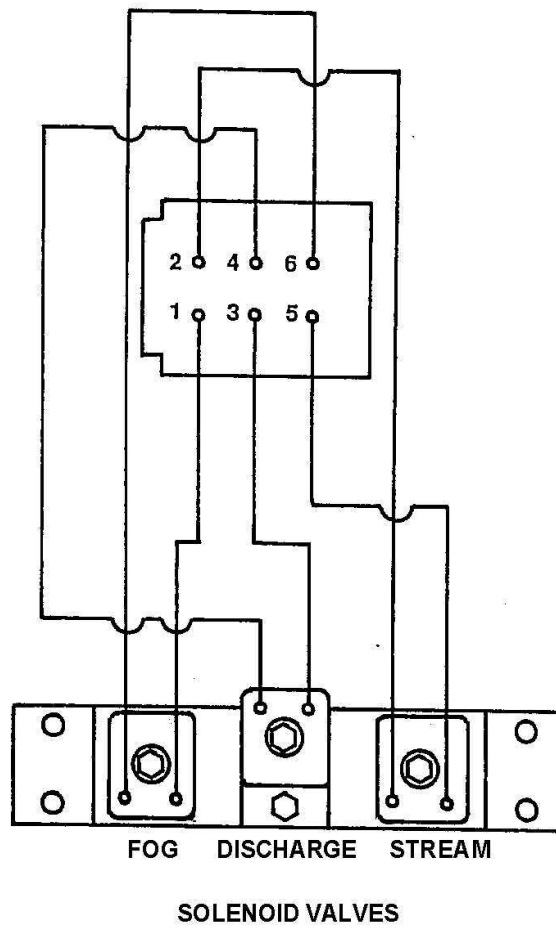

Figure B-1 Solenoid Valve Assembly Schematic.

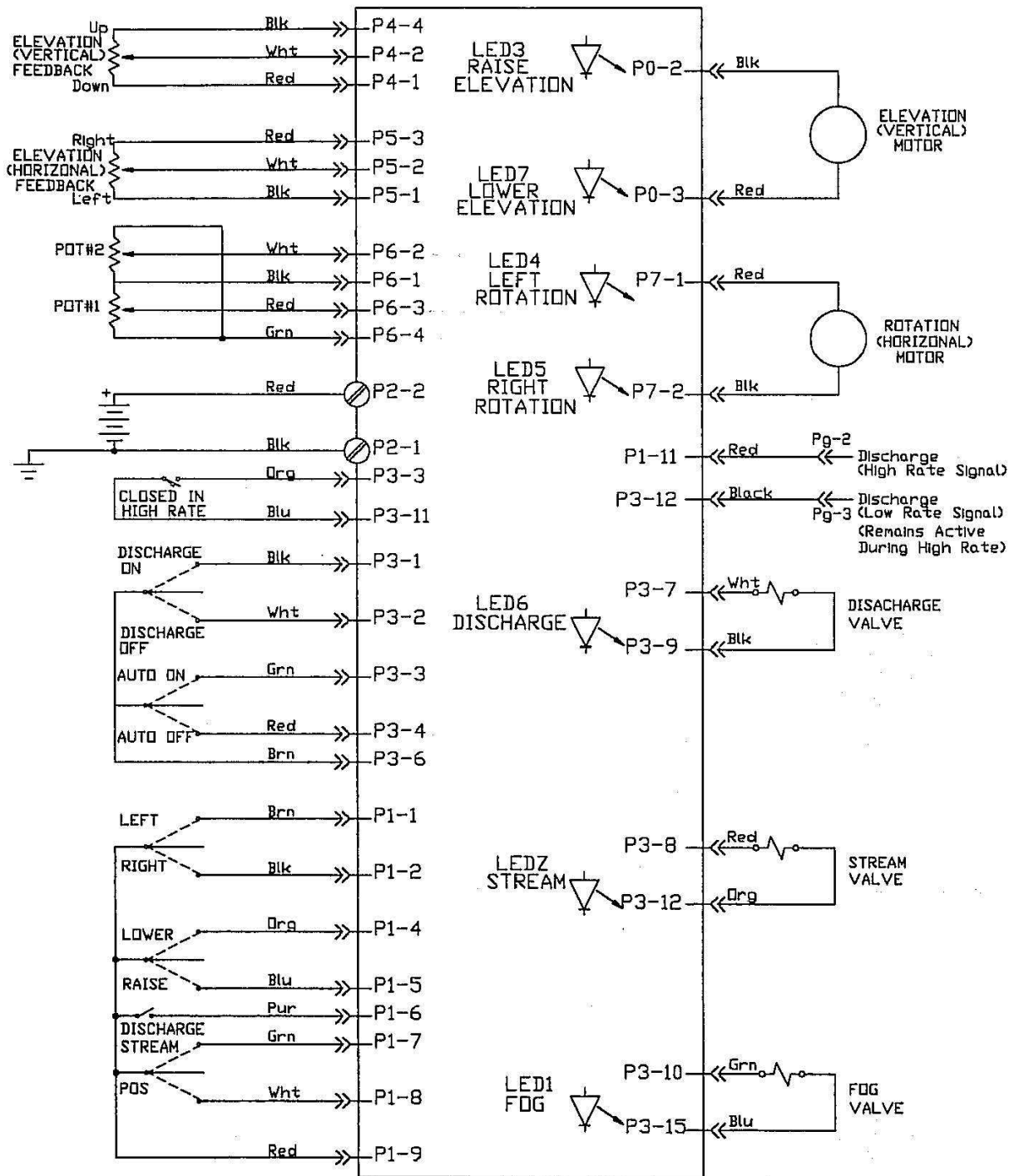

Figure B-2. Roof Turret System Schematic.

RECORD OF CHANGES

<u>CHANGE DATE</u>	<u>DESCRIPTION OF CHANGE</u>	<u>INCORPORATED BY</u>
10/9/2008	Revised part #'s and combined type 1&2 Turret info	R.Tharp