



STYLE 3440 DECKMASTER™ ELECTRIC MONITOR WITH POSITION FEEDBACK INSTALLATION, OPERATING, AND MAINTENANCE INSTRUCTIONS

The following is intended to provide the basic instructions for installation, operation and maintenance of the DeckMaster electric monitor with position feedback, and to assist in attaining the best possible performance from the unit. Read and understand these operating instructions before use.

TOOLS REQUIRED

- Utility Knife
- Medium flat screwdriver
- Medium Phillips screwdriver
- Small flat screwdriver
- Small Phillips screwdriver
- 1/2 inch hex head wrench
- Electrician's pliers (multipurpose, stripping and crimping)

PRODUCT RATINGS

Maximum Motor Current Draw:

12 volt versions	14.0 amps each for elevation and rotation motors 3.0 amps for nozzle pattern motor
24 volt versions	7.5 amps each for elevation and rotation motors 1.5 amps for nozzle pattern motor

Normal Operating Current: (Depending on operating conditions—pressure, flow, etc.)

12 volt versions	3.0 to 10.0 amps each for elevation, rotation, and stow motors 0.7 amps for nozzle pattern motor
24 volt versions	2 - 5 amps each for elevation and rotation motors 0.4 amps for nozzle pattern motor

Minimum Voltage: **(Truck engine must be operating for proper voltage requirement.)**

All 12 volt motors: 11.5 volts while operating

All 24 volt motors: 23 volts while operating

Maximum Flow: 1250 gpm (4800 lpm)

Maximum Pressure: 200 psi (14 bar)

PRODUCT WARNINGS

WARNING: For fire fighting use only by trained fire fighters.

WARNING: Charge the unit slowly. Rapid charging may cause a pressure surge that has the potential to cause an injury, or damage the monitor.

WARNING: DO NOT stow or deploy the DeckMaster monitor while flowing. Pressing the stow or deploy buttons causes the nozzle to move automatically and the water stream may cause damage to equipment or injury to personnel could result.

WARNING: Aim the unit in a safe direction before pumping water through it. (i.e. Away from power lines)

WARNING: Although the logic circuit board includes a water-resistant coating, it is important to keep water out of the control box and logic box. Prolonged exposure to water will cause damage. When the cover of the control box or logic box is removed, check that the O-ring under the cover is intact and free of dirt and debris.

WARNING: The DeckMaster monitor uses current limiting for both the monitor and nozzle. Use only appropriate Akron Brass Company nozzles.

WARNING: Do not use the electric controls when the override cranks are being used or are in position for use.

WARNING: Make the connection of the vehicle and auxiliary battery the final step.

WARNING: Replace the identification tags if they should become worn or damaged.

WARNING: DO NOT exceed the maximum pressure or flow ratings of the monitor. Exceeding these ratings may lead to an injury or may cause damage to the monitor.

WARNING: DO NOT install shutoffs on the outlet of the DeckMaster electric monitor. Shutoffs increase the potential

for pressure surges due to water hammer, which have the potential to cause an injury or damage the monitor.

WARNING: If not equipped with an automatic drain valve, drain the DeckMaster monitor after use to prevent “freeze damage”.

WARNING: Ensure the thread on the nozzle swivel matches the thread on the monitor outlet. Do not over tighten the nozzle onto the unit.

WARNING: The DeckMaster monitor, nozzle, logic box, control box, tether controller, and field adjustable stops are made for optimal performance. Do not alter in any manner.

WARNING: Do not install the DeckMaster onto any extension devices including but not limited to telescoping water ways or detachable extension pipes.

WARNING: Ensure that the DeckMaster is returned to the stow position after use.

WARNING: The DeckMaster monitor was designed for use with the Akromatic 1250 or Turbomaster nozzles. Use of any other nozzle could affect the speed or operation of the unit and should be tested before being put into service.

MECHANICAL MONITOR ATTACHMENT

WARNING: INSUFFICIENT STRUCTURAL SUPPORT CAN LEAD TO FAILURE, WHICH HAS POTENTIAL TO CAUSE AN INJURY. THEREFORE, ADDITIONAL STRUCTURAL SUPPORT AT THE INLET FLANGE OR AT THE INLET ELBOW MAY BE REQUIRED. (Contact Akron Brass Customer Service for assistance.)

The DeckMaster monitor is to be mounted on the waterway with four 5/8” bolts and nuts of grade five minimum and suitable washers with a minimum of six threads engagement. The notch that is cut in the side of the inlet flange is the front of the monitor (Figure 2). The bolts must be tightened in a criss-cross pattern progressively increasing tightening torque to a maximum of 100 lb.ft.dry.

ROTATIONAL STOPS

The rotational stops set the boundaries for the area that the monitor is allowed to travel. The lower row controls the clockwise travel, and the upper row controls the counter-clockwise travel. The angles for the rotational stops are with respect to the reference direction illustrated in Figure 2. The monitor is shipped with the lower row stop at point 1 which stops the monitor at 170° clockwise and the upper row stop at point 5 which stops the monitor at 170° counter-clockwise. All other positions are achieved by switching the factory set stop and the plug in the desired location. Both the plugs and the stops have a 1/2” hex head. Refer to Figure 2 to determine which stop location is needed for the desired clockwise or counter-clockwise rotation. Additional “soft” stops can be set, see “learn mode” section on page 4.

LIMIT SWITCH

The DeckMaster monitor has been provided with one limit switch. This limit switch indicates when the monitor is in either stow or deploy mode and should not be set or adjusted in any manner.

MECHANICAL ATTACHMENT OF CONTROLLER AND LOGIC BOX

A. CONTROLLER AND TETHER CONNECTOR ATTACHMENT

The panel mount controller mounts directly into the pump panel. Pump panel cut out and mounting hole dimensions are given in Figure 3. The panel mount controller and tether connector should be installed in the pump panel prior to electrical connection to the logic box.

B. LOGIC BOX ATTACHMENT

The DeckMaster logic box mounts on or below the deck and must be mounted close enough to the monitor to allow the 8 ft. monitor wiring harness sufficient slack to allow the monitor to travel through its full range. The logic box overall dimensions and mounting hole dimensions are given in Figure 4.

WARNING: Do not extend the monitor wiring harness.

ELECTRICAL INSTALLATION INSTRUCTIONS

A. PANEL CONTROLLER OR TETHER CONNECTOR ELECTRICAL ATTACHMENT

These instructions are for attaching the panel controller or the tether connector to the logic box. The panel mount controller and tether connector are supplied with 8 ft. of cable.

STEP 1 Determine the length of cable needed, add 6” and then cut the remainder off.

STEP 2 Remove the cable grip nut for the appropriate cable from the logic box, DO NOT REMOVE THE CABLE GRIP. Thread cable grip nut on the cable with the threads facing out. On the same end of the cable, remove 6 inches of the outer casing of the cable and strip back 3/8” from each of the wires.

STEP 3 Loosen the 4 logic box cover screws and set the logic box cover aside. Thread the wires through the appropriate hole in the logic box (see Figure 4). Pull enough cable through the cable grip to ensure a good fit. Tighten the cable grip nut and attach the individual wires to the proper terminals (see wiring diagram, Figure 5). Note: The panel controller and the tether connector can be attached to either terminal: Master (TB2) or Slave (TB3). The one attached to the Master (TB2) terminal will have the

overriding capabilities. Adjust the DIP switch settings as needed. (Refer to the description below). Reattach the logic box cover and secure with the 4 screws.

B. DIP SWITCH SETTINGS

The DIP switches are located in the logic box on the circuit board.

The switches are factory set at:

	1	2	3	4	5	6	7	8
On						•	•	•
Off	•	•	•	•	•			

Switch 1 - ON uses a timer on the elevation arm during the stow sequence. OFF uses current limiting for the elevation arm.

Switch 2 - ON lowers the outlet elbow during the stow sequence until it current limits (hits a hardstop). Used to stow nozzle in cradle. OFF will stow the outlet elbow at the HOME position.

Switch 3 - ON requires a jog to stow or deploy the monitor. OFF allows a single push of the Stow/Deploy button to complete the stow or deploy sequence.

Switch 4 - Reserved for factory

Switch 5 - ON returns the nozzle pattern to straight stream during the stow sequence. OFF will make the nozzle pattern remain in the most recent position during stow.

Switch 6 - ON allows operation of the rotation, elevation, and nozzle pattern controls while in the stow position. OFF disables operation while in the stow position.

Switch 7 - ON requires the monitor to stow at the HOME position. OFF allows the unit to stow at any rotational position. (HOME position is an adjustable horizontal position set by the customer. See “learn mode” section on page 4.)

Switch 8 - ON enables the learn mode. OFF disables the learn mode, but keeps the settings in memory.

C. MONITOR, VEHICLE BATTERY, OR CAB INDICATOR LIGHT ELECTRICAL ATTACHMENT

These instructions are for attachment of the monitor wiring harness, the vehicle battery, and the cab warning light to the logic box. **Note:** The DeckMaster has current limit circuitry; there must be appropriate power to the Logic Box for the monitor to operate properly. It is recommended to wire the Power Leads directly to the Vehicle Battery with 10Awg or 12Awg wiring with no intermediate connections.

STEP 4 Remove the cable grip nut for the appropriate cable from the logic box (see Figure 4), DO NOT REMOVE THE CABLE GRIP. Thread the cable grip nut on the correct cable with the threads facing out.

STEP 5 Loosen the 6 logic box cover screws and set the logic box cover aside. Thread the cable through the correct logic box cable grip (see Figure 4). Pull enough cable through the cable grip to ensure a good fit. Tighten the cable grip nut and attach the individual wires to the proper terminals (see wiring diagram, Figure 5). Reattach the logic box cover and secure with the 6 screws.

Note: To supply enough current to operate the monitor properly, adequate wire size is critical (10 Awg recommended).

OPERATING INSTRUCTIONS

A. PANEL CONTROLLER OPERATION

The panel controller is used to control the monitor and nozzle.

- To deploy the monitor for use:
Lift the safety cover on the STOW/DEPLOY switch and push the toggle switch up and release.
- To stow the monitor after use:
Lift the safety cover on the STOW/DEPLOY switch and push the toggle switch down and release.
- To change the horizontal monitor position toward the right or left:
Press the proper toggle switch toward “RIGHT” or “LEFT” respectively, as labeled on the controller, until the desired position is reached.
- To change the vertical monitor nozzle position upward or downward:
Press the proper toggle switch toward “RAISE” or “LOWER” respectively, as labeled on the controller, until the desired position is reached.
- To change the nozzle pattern toward the straight stream or fog position:
Press the proper toggle switch toward “STRAIGHT” or “FOG” respectively, as labeled on the controller, until the desired nozzle position is reached.

B. EMERGENCY STOP DURING DEPLOY OR STOW

If it is necessary to immediately stop the DeckMaster monitor during the deploy or stow sequence, activate any switch on the control panel and the unit

will stop moving (E-Stop). To complete the stow or deploy sequence after an emergency stop, jog the unit to its Stow or Deploy final position by holding the STOW/DEPLOY toggle switch. Be sure to completely stow or deploy before flowing water.

C. MANUAL OVERRIDE CONTROLS

The manual override control is to be used only when the power to the monitor is off. A single override crank with a 1/4" hex drive is provided and attached to the monitor for use on both the horizontal and vertical override controls and the stow/deploy control. To use the manual override, insert the hex drive end of the override crank into the hexagon shaped hole on the shaft end opposite the motor. Rotate the override crank in the desired direction to aim the monitor.

WARNING: When the override crank is no longer in use, put it back in the storage position. Do not use the electric controls when the override crank is being used or is in position for use.

D. LEARN MODE

NOTE: Dip switch #8 has to be on (up) to enable learn mode. After learning is complete turn dip switch #8 off to prevent accidental changes.

The learn mode allows the operator to teach the monitor a new final Up/Down positions for the nozzle at the stow or deploy position, and "soft" stop operational limits for rotation and elevation.

Rotation and Elevation Limits:

The soft limits are not set at the factory. To change the soft limits:

- Shut down Power to monitor.
- Hold down the SS switch and turn the power on. Release the SS switch.
- The LED will flash twice for the set-up mode of the Rotation and Elevation limits.
- To continue to the stow/deploy set-up mode press and release the SS switch. The LED will flash three times for stow/deploy setup mode.

Rotation Limits

- Move the monitor to the desired Left limit (release the switch)
- Hold down the Fog switch and press and release the Left switch and then release the Fog switch. This will set the Left limit.
- Move the monitor to the desired Right limit (release the switch)
- Hold down the Fog switch and press and release the Right switch and then release the Fog switch. This will set the Right limit.

Elevation Limits

- Move the monitor to the desired upper limit (release the switch)
- Hold down the Fog switch and press and release the Raise switch and then release the Fog switch. This will set the upper limit.
- Move the monitor to the desired lower limit (release the switch)
- Hold down the Fog switch and press and release the Lower switch and then release the Fog switch. This will set the lower limit.

Press and release the SS switch to exit the Rotation and Elevation set-up mode and enter stow/deploy learn mode.

Stow/Deploy:

- The LED will flash three items for the set-up mode for the Stow and Deploy.

Stow Position

- Move the monitor to the desired stow position.
- Hold down the Fog switch and press and release the Stow switch and then release the Fog switch. This will set the Stow position.
- Deploy Position (if applicable)
- Move the monitor to the desired Deploy position.
- Hold down the Fog switch and press and release the Deploy switch and then release the Fog switch. This will set the Deploy position.

Press and release the SS switch to exit the Set-up mode.

WARNING: The nozzle position may need to be reprogrammed in the event of variable loads on the motor. Possible load situations include extreme temperatures, changing nozzles, wear and tear, etc.

MAINTENANCE INSTRUCTIONS

Your DeckMaster monitor and nozzle should be inspected prior to and after each use to ensure it is in good operating condition. Periodically, an unanticipated incident occurs where the unit is misused in a manner that is inconsistent with standard operating practices. A partial list of potential misuses includes:

- Operating above the maximum rated pressure or flow.
- Prolonged exposure to temperatures above 130°F, or below -25°F.
- Operating in a corrosive environment.
- Having the DeckMaster nozzle hit a fixed object during operation or transportation.
- Any other misuse that might be unique to your specific environment.

Also, there are many “tell tale” signs that indicate repair is in order, such as:

- Controls that are either inoperable or difficult to operate.
- Excessive wear
- Poor discharge performance
- Water leaks.

If any of the above situations are encountered, the DeckMaster monitor should be taken out of service, repaired, and tested by a qualified technician before placing back in service.

A. MOTOR REPLACEMENT

To replace the horizontal, vertical motors:

1. Disconnect power from the unit.
2. Loosen and remove the 4 socket screws from the gearbox housing
3. Slowly remove the motor assembly and gearbox housing from the unit.
Important: Make sure the internal gear remains in place, (hold with a screwdriver), to avoid gear alignment problems.
4. Loosen and remove the 4 socket head cap screws from the inside of the gearbox housing that holds the housing and the motor assembly together.
5. Remove the gearbox housing from the motor assembly.
6. Replace both O-ring seals on the gearbox housing.
7. Attach the new motor assembly to the gearbox housing, making sure all 4 screws are tight.
8. Install the motor and gearbox housing assembly to the unit making sure all 4 socket screws are tight. It may be necessary to rotate the motor slightly to get the motor gear to line up with the gears inside the gearbox, or use the override crank.
9. Restore power to the unit.
10. Test the operation of the unit.

Call Akron Brass Technical Service if any problems are encountered.

B. FAULT CODES

Your DeckMaster monitor comes with built in diagnostic tools. On the control panel is a small LED indicator. The primary function of the LED indicator is to indicate whether the monitor is stowed or deployed. The LED indicator also functions as a Fault Indicator.

Deployed: The light will repeatedly flash twice as the unit is deploying. When the fully deployed position is reached the light will stop flashing and remain on.

NOTE: As soon as the deploy sequence begins, the light in the cab will turn on.

Stowed: When the fully stowed position is reached the LED indicator will go out.

NOTE: The light in the cab will also go out when fully stowed.

Fault Code 1: Fault code 1 is represented when the light flashes continually. If the EEPROM on the circuit board is faulty, Fault 1 will occur.

Correction: The circuit board must be replaced

Fault Code 2: Fault code 2 is normal during the deploy sequence and is represented when the light repeatedly flashes twice. Code 2 is not a fault, but occurs when the deploy button is pressed and automatically ends when the fully deployed position is reached. Operation of any switch while flashing twice will cause the monitor to go into E-stop mode. (See Fault Codes)

Fault Code 3: Fault code 3 is represented when the light repeatedly flashes 3 times. This fault code indicates an emergency stop (E-stops) occurred during stow or deploy. If any switch is pushed during the stow or deploy sequence all movement will stop and Fault 3 will flash.

Correction: Jog the deploy or stow switch by holding the switch on until the light stays on constantly at full deployment or turns off at stow. Make sure the nozzle outlet is pointed in a safe direction, as the nozzle deployment is not automatic in the manual mode.

Fault Code 4: Fault code 4 is represented when the light repeatedly flashes 4 times. If the Deploy switch is pushed and the monitor is prevented from completing the deploy sequence, Fault 4 will occur.

Correction: Check for an obstruction by the monitor. Remove the obstruction and then jog the deploy switch by holding the switch on until the light stays on constantly at full deployment. Make sure the nozzle outlet is pointed in a safe direction, as the nozzle deployment is not automatic in the manual mode.

Fault Code 5: Fault code 5 is represented when the light repeatedly flashes 5 times. If the Deploy switch is pushed, and the nozzle movement is blocked or moves to the end of its travel, (pointed down), Fault 5 will occur.

Correction: Press the up control until the light stops flashing and check for any obstructions. If error 5 continues or occurs frequently, reset the deployed nozzle outlet position as described in the “Learn Mode” section. If the error continues after reset, call Akron Brass Customer Service.

Fault Code 6: Fault code 6 is represented when the light repeatedly flashes 6 times. If the stow switch is pushed, and

the monitor cannot find the home rotation position, Fault 6 will occur.

Correction:

The motor will continue to reverse direction until the home position is found at which time the LED will stop flashing. If home position is not found, the position feedback sensor may be faulty. The sensor and associated wiring must be checked for proper function.

Fault Code 7:

Fault code 7 is represented when the light repeatedly flashes 7 times. If the stow switch is pushed, and the nozzle takes longer than 30 seconds to reach the end of its travel, Fault 7 will occur.

Correction:

Press the up or down control to clear the error. Check the mechanical gearbox and wiring for the elevation motor. Call Akron Brass Customer Service.

Fault Code 8:

Fault code 8 is represented when the light repeatedly flashes 8 times. If the stow switch is pushed and the monitor does not reach the stow position, Fault 8 will occur.

Correction:

Check for an obstruction by the monitor. Remove the obstruction and then jog the stow switch by holding the switch on until the LED light turns off at the stow position. Make sure the nozzle outlet is pointed in a safe direction, as the nozzle deployment is not automatic in the manual mode.

Fault Code 9:

Fault code 9 is represented when the light repeatedly flashes 9 times. If the stow switch is pushed and the monitor moves to the stowed position but the nozzle does not reach the "learned stow position", Fault 9 will occur.

Correction:

Check for and remove any obstruction. If no obstruction, check nozzle position sensor and associated wiring for proper function. Then use learn mode to set nozzle stow position.

Figure 1

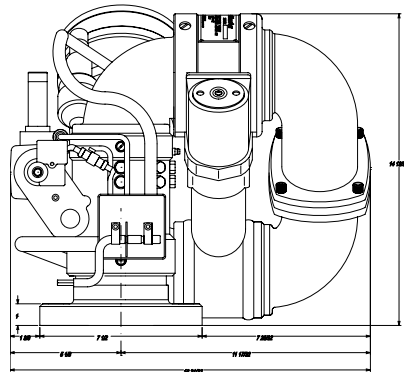

REAR VIEW - STOWED

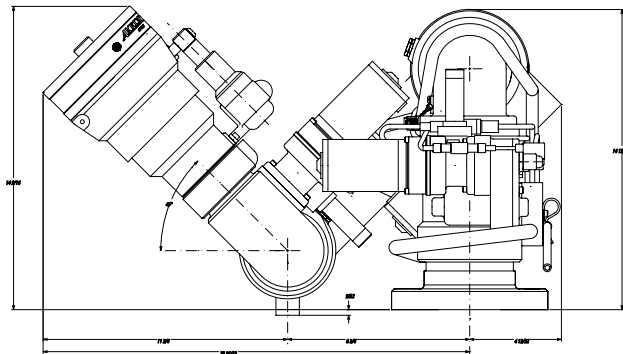

SIDE VIEW - STOWED

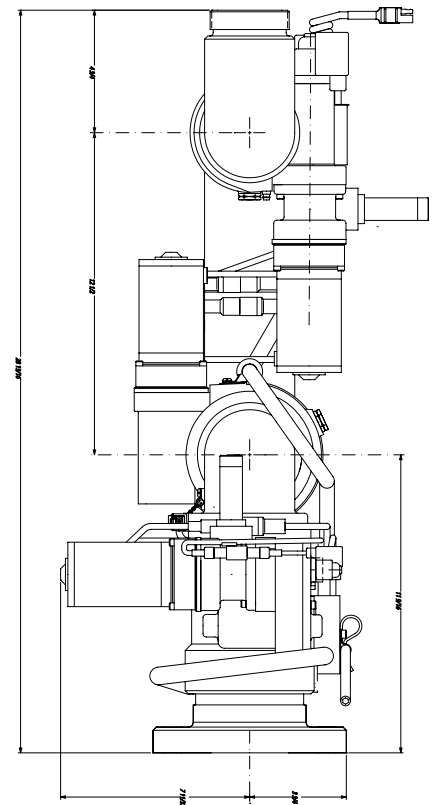

SIDE VIEW - DEPLOYED

Figure 2

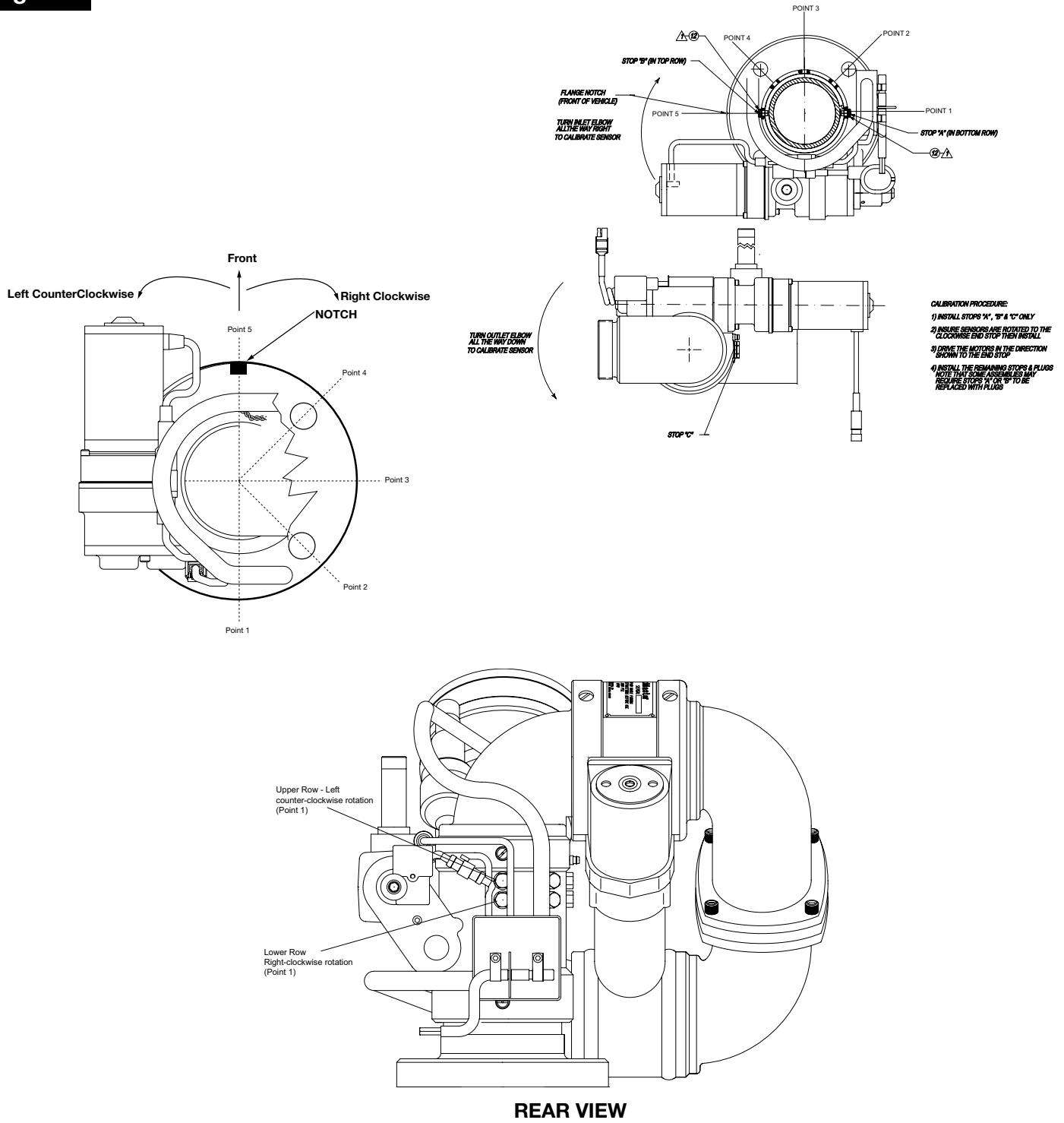

UPPER ROW (CCW)		1	2	3	4	5
LOWER ROW (CW)	1	0/170	45/170	90/170	135/170	170/170
	2	0/135	45/135	90/135	135/135	170/135
	3	0/90	45/90	90/90	135/90	170/90
	4	0/45	45/45	90/45	135/45	170/45
	5	0/0	45/0	90/0	135/0	170/0

FACTORY SET STOPS

Figure 3

PANEL MOUNT CONTROLLER

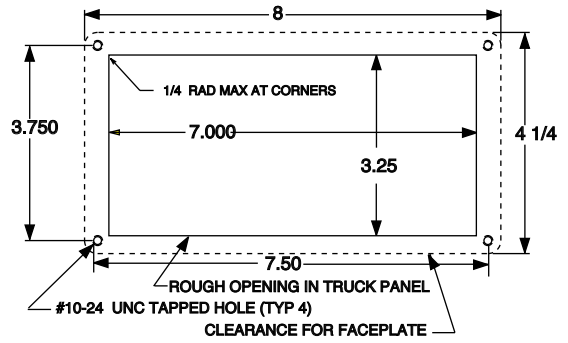
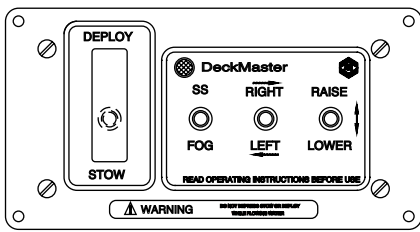
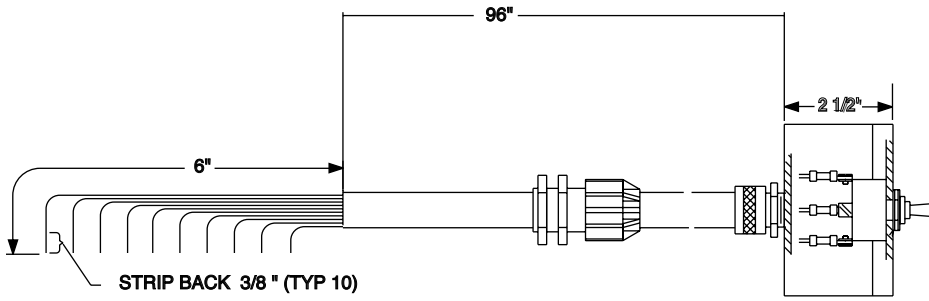

TRUCK PANEL CUTOUT DIMENSIONS

TETHER CONNECTOR

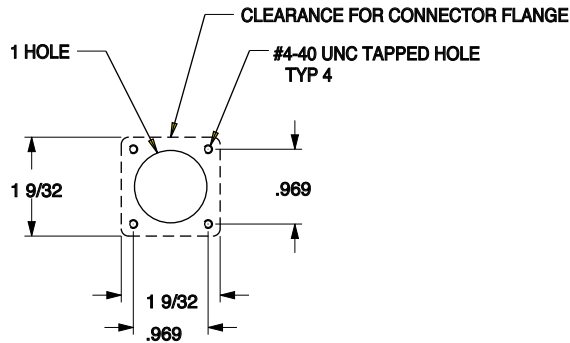
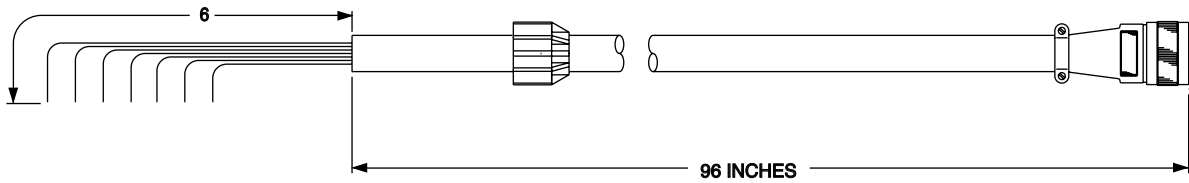

PANEL MOUNTING DIMENSIONS

Figure 4

LOGIC BOX

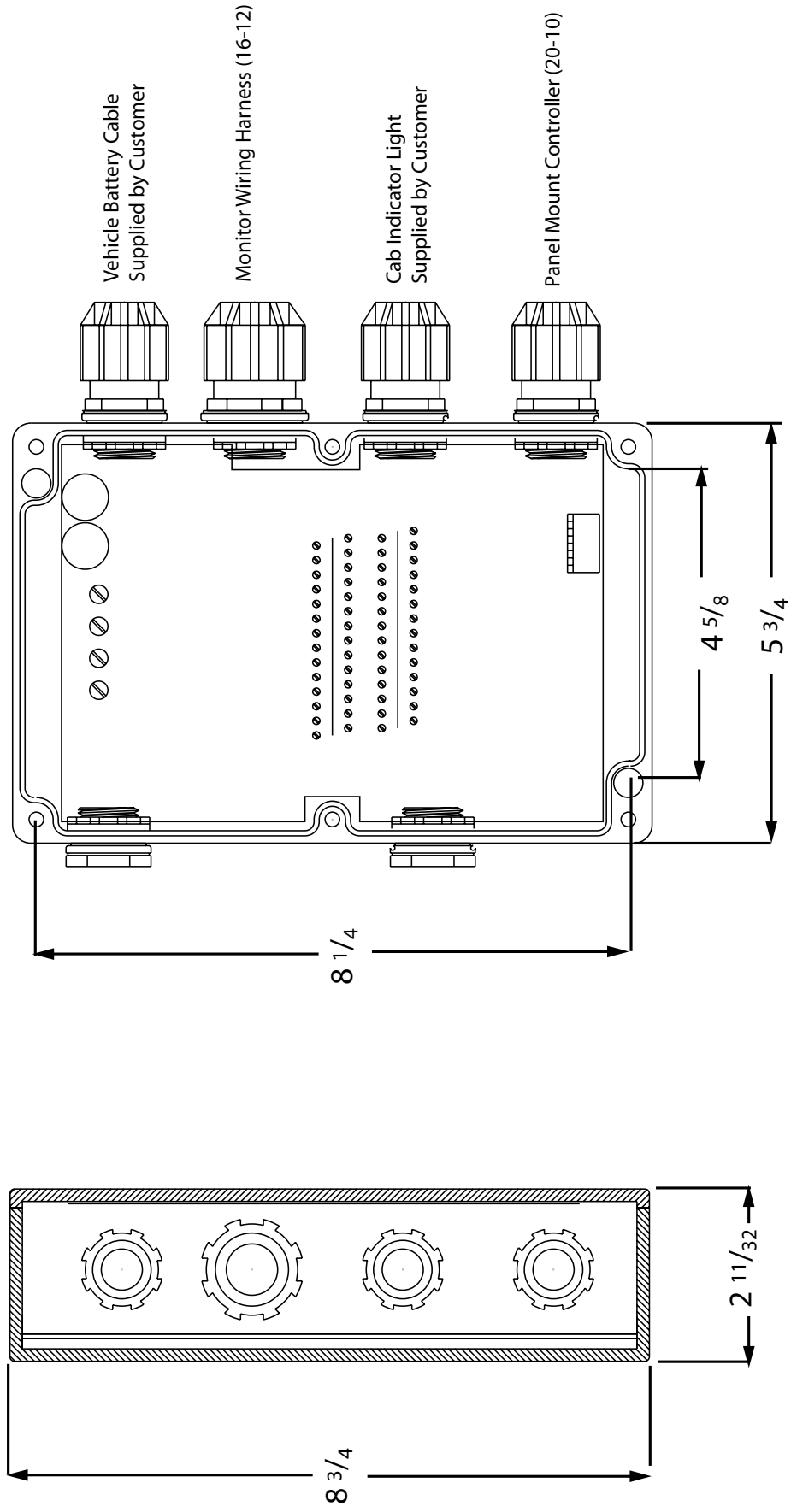
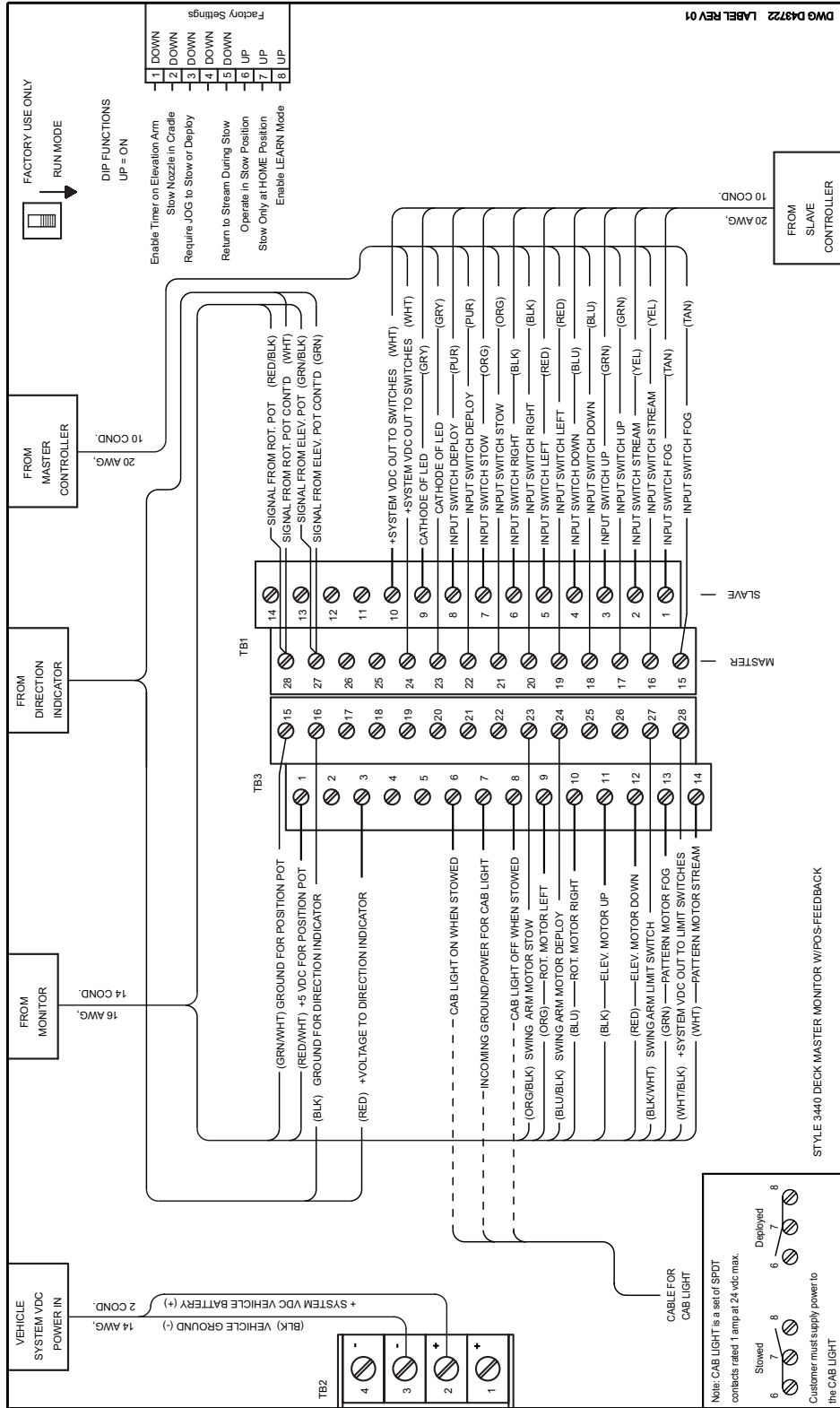

Figure 5



Tested...Proven...Trusted.

ISO 9001 REGISTERED COMPANY

PHONE: 330.264.5678 or 800.228.1161 | FAX: 330.264.2944 or 800.531.7335 | akronbrass.com

REVISED: 8/08

WARRANTY AND DISCLAIMER: We warrant Akron Brass products for a period of five (5) years after purchase against defects in materials or workmanship. Akron Brass will repair or replace product which fails to satisfy this warranty. Repair or replacement shall be at the discretion of Akron Brass. Products must be promptly returned to Akron Brass for warranty service.

We will not be responsible for: wear and tear; any improper installation, use, maintenance or storage; negligence of the owner or user; repair or modification after delivery; damage; failure to follow our instructions or recommendations; or anything else beyond our control. WE MAKE NO WARRANTIES, EXPRESS OR IMPLIED, OTHER THAN THOSE INCLUDED IN THIS WARRANTY STATEMENT, AND WE DISCLAIM ANY IMPLIED WARRANTY OF MERCHANTABILITY OR FITNESS FOR ANY PARTICULAR PURPOSE. Further, we will not be responsible for any consequential, incidental or indirect damages (including, but not limited to, any loss of profits) from any cause whatsoever. No person has authority to change this warranty.

© Akron Brass Company, 2000 All rights reserved. No portion of this can be reproduced without the express written consent of Akron Brass Company.