



ASSEMBLY NOTES:
USE PARKER-O-LUBE ON ALL O-RINGS
AND ALL MATING SURFACES.

-  USE LOCTITE 222 OR PERMABOND LM 113
-  USE LOW-TEMP LUBRIPLATE
-  USE LOCTITE 680



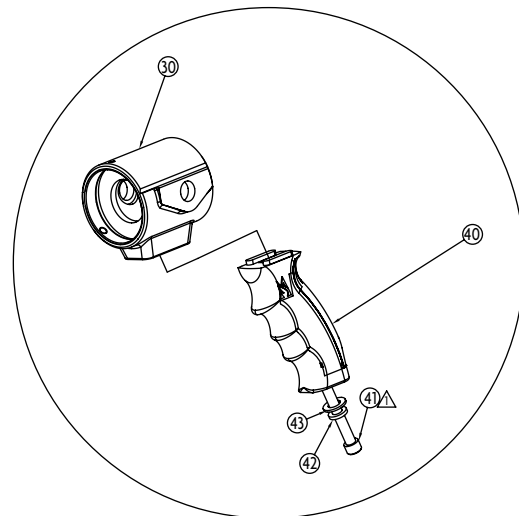
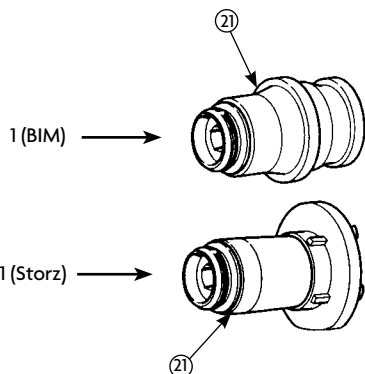

**STYLE 3025 & 3033
AFF Nozzle
TECHNICAL SERVICE PARTS LIST**

ITEM NO.	DESCRIPTION	PART NUMBER	3025 QUANTITY	3033 QUANTITY
1	Indicating Band (Government)	703241	1	
1	Indicating Band (gpm)	803012		1
1	Indicating Band (lpm)	803013		1
2	Screw Socket Head Set	765002	2	2
3	Bumper **	704165	1	1
4	Pattern Sleeve	105621	1	1
5	O-Ring (2-135)	757193	1	1
6	Throat	105614	1	1
7	Pin Retaining	744179	3	3
8	O-Ring (2-129)	757194	1	1
9	Spring	768160	1	1
10	Stop Screw	767097	1	1
11	O-Ring (2-141)	757195	1	1
12	Nozzle Body	119471	1	1
13	O-ring (2-140)	757182	1	1
14	Shutoff Handle (Black)	721427	1	1
15	Trunnion	773110	2	2
16	Roll Pin	744062	2	2
17	Swivel Adapter #	105609	1	1
18	Piston Ring #	756003	1	1
19	O-ring (2-224) #	757182	1	1
20	Gasket (NH)	717043	1	1
21	Swivel Sub-Assembly 2 1/2" NH (Standard)*	30250002	1	1
21	Swivel Sub-Assembly 2 1/2" NPSH (Optional)*	30250007	1	1
21	Swivel Sub-Assembly BIM (Optional)	37250006	1	1
21	Swivel Sub-Assembly 52 mm Storz (Optional)	37330002	1	1
22	Screw Socket Head Cap	765029	1	1
23	Baffle Head	106202	1	1
24	Shim (Blue)	768190	1	1
25	Baffle Stem	768350	1	1
26	O-Ring (2-132)	757197	2	2
27	Seat	769243	2	2
28	O-Ring (2-111)	757198	2	2
29	Ball	704029	1	1
30	Shutoff Body (Style 3033) For Pistol Grip	123236		1
30	Shutoff Body (Style 3025) With Out Pistol Grip	105915	1	
31	O-Ring (2-137)	757203	1	1
32	Spider	769578	1	1
33	Ring	756151	1	1
34	Screw Button Head	765149	1	1
35	Baffle Washer	784110	1	1
40	Pistol Grip- Black	718233		1
41	Screw Socket Head Cap	763064		1
42	Lock Washer 5/16	784090		1
43	Flat Washer 5/16	784093		1

* For other threads, order by description and thread size (ODM and TPI) or by Akron Brass thread code.

** The bumper is pressed on and timed with pattern the sleeve. It may need to be returned to the factory for proper assembly.

Included with Swivel Sub-Assembly



ISO 9001 REGISTERED COMPANY

PHONE: 330.264.5678 or 800.228.1161 | FAX: 330.264.2944 or 800.531.7335 | akronbrass.com

REVISED: 6/11

WARRANTY AND DISCLAIMER: We warrant Akron Brass products for a period of five (5) years after purchase against defects in materials or workmanship. Akron Brass will repair or replace product which fails to satisfy this warranty. Repair or replacement shall be at the discretion of Akron Brass. Products must be promptly returned to Akron Brass for warranty service.

We will not be responsible for: wear and tear; any improper installation, use, maintenance or storage; negligence of the owner or user; repair or modification after delivery; damage; failure to follow our instructions or recommendations; or anything else beyond our control. WE MAKE NO WARRANTIES, EXPRESS OR IMPLIED, OTHER THAN THOSE INCLUDED IN THIS WARRANTY STATEMENT, AND WE DISCLAIM ANY IMPLIED WARRANTY OF MERCHANTABILITY OR FITNESS FOR ANY PARTICULAR PURPOSE. Further, we will not be responsible for any consequential, incidental or indirect damages (including, but not limited to, any loss of profits) from any cause whatsoever. No person has authority to change this warranty.

© Akron Brass Company. 2011 All rights reserved. No portion of this can be reproduced without the express written consent of Akron Brass Company.