

- NOTES:**
- ① USE PERMABOND 113 OR LOCTITE 222.
 - ② USE PERMABOND HH-120 OR LOCTITE 277.
 - ③ DIMPLE AT ASSEMBLY.
 - ④ TORQUE TO 35-45 IN-LBS.
 - ⑤ USE LOW TEMP LUBRIPLATE.
 - ⑥ CENTER A BALL IN LOADING HOLE. SCREW IN SET SCREW UNTIL IT MAKES CONTACT WITH BALL. BACK OUT SET SCREW "SLIGHTLY" UNTIL SPINDLE MOVES FREELY.
 - ⑦ DO NOT CUT SPINNING TEETH.
 - ⑧ STAMP LAST 2 DIGIT OF YEAR AFTER CALIBRATION.
 - ⑨ USE LOCTITE 680.
 - ⑩ USE PERMABOND HH-120 OR LOCTITE 277 AFTER CALIBRATION.

PHONE: 330.264.5678 or 800.228.1161 | FAX: 330.264.2944 or 800.531.7335 | www.akronbrass.com

Parts List Sheet:

122661

WARRANTY AND DISCLAIMER: We warrant Akron Brass products for a period of five (5) years* after purchase against defects in materials or workmanship. Akron Brass will repair or replace product which fails to satisfy this warranty. Repair or replacement shall be at the discretion of Akron Brass. Products must be promptly returned to Akron Brass for warranty service. We will not be responsible for: wear and tear; any improper installation, use, maintenance or storage; negligence of the owner or user; repair or modification after delivery; failure to follow our instructions or recommendations; or anything else beyond our control. WE MAKE NO WARRANTIES, EXPRESS OR IMPLIED, OTHER THAN THOSE INCLUDED IN THIS WARRANTY STATEMENT, AND WE DISCLAIM ANY IMPLIED WARRANTY OF MERCHANTABILITY OR FITNESS FOR ANY PARTICULAR PURPOSE. Further, we will not be responsible for any consequential, incidental or indirect damages (including, but not limited to, any loss of profits) from any cause whatsoever. No person has authority to change this warranty. *Unless otherwise provided herein. Akron Brass industrial electronic components & the Severe-Duty Monitor have a one (1) year warranty. Weldon products have a one (1) year warranty (excluding consumable components). Select Weldon LED products carry a five (5) year warranty. For Weldon product returns call 800-989-2718. Honda products have the manufacturers' warranty and Akron Brass disclaims any warranty in respect of those products.

Find	Description	Item	QTY
1	BODY NOZZLE	117893	1
2	THROAT	117892	1
3	BAFFLE HEAD	117895	1
4	STEM BAFFLE	768307	1
5	SPRING	769634	1
6	PIN GROOVE 5/32" x 3/4"	741056	1
7	SLEEVE PATTERN	117894	1
8	GASKET	717042	1
9	SWIVEL 1.5" NH	101928*	1
10	RING PISTON	756003*	1
11	SCREW HEX HEAD SHOULDER 1/2D x 1" x 3/8-16	765198	1
12	O-RING 2-129	757308	1
13	TEETH TURBINE	772153	1
14	SCREW SOCKET HEAD CAP #4-40 x 3/8"	767019	2
15	RING FULL DISPERSE RETAINING	758241	1
15	RING FLAT DISPERSE RETAINING	118421	1
15	RING PATTERN SLEEVE (NO TEETH)	120406	1
16	O-RING 2-132	757268	1
17	O-RING 2-036	757309	1
18	SPRING LEFT HAND COIL	769629	1
19	HOUSING SCREW	122669	1
20	O-RING 2-122	757335	1
22	SCREW ACME	765344	1
23	TUBE PATTERN ACTUATOR GUIDE	122668	1
24	O-RING 2-127	757048	1
25	BALL 3/16" SST	704018**	24
26	SCREW SOCKET HEAD FLAT POINT SET 5/16-24 x 1/4"	765134	1
27	GEAR BALLSCREW	718298	1
28	NUT HEX 1/4-20	734061	1
29	WORM PATTERN ACTUATOR	785021	1
30	PIN ROLL 1/16" x 3/8"	744341	1
34	O-RING 2-029	757056	1
35	O-RING 2-015	757112	1
36	MOTOR 12V	33560007	1
36	MOTOR 24V	33560010	1
39	SCREW SOCKET HEAD CAP #6-32 x 1/2"	765150	4
38	SHIM PLASTIC GREEN	768308***	1
40	SHIM PLASTIC BLUE	768218***	1
41	SHIM PLASTIC BROWN	768219***	1
42	SHIM PLASTIC PINK	768220***	1
43	PIN RETAINING	744178	3
44	BAND ID 12VOLT	704645	1
44	BAND ID 24VOLT	704646	1
51	NUT ACME SCREW	734115	1
52	WASHER	784210	2
53	WASHER BELEVILE	784071	2
54	SCREW SOCKET HEAD CUP POINT SET #10-32 x 1/8"	765168	1
55	SCREW SOCKET HEAD CUP POINT SET #10-32 x 5/16"	765177	1

* THE SWIVEL AND PISTON RING ARE A PERMANENT ATTACHMENT AND CANNOT BE REPLACED IN THE FIELD. THE NOZZLE MUST BE SENT BACK TO AKRON BRASS FOR REPAIR.
 ** KIT OF 50 BALLS 121874
 *** INSTALLED AT FACTORY AS NEEDED FOR FINAL FLOW CALIBRATION.

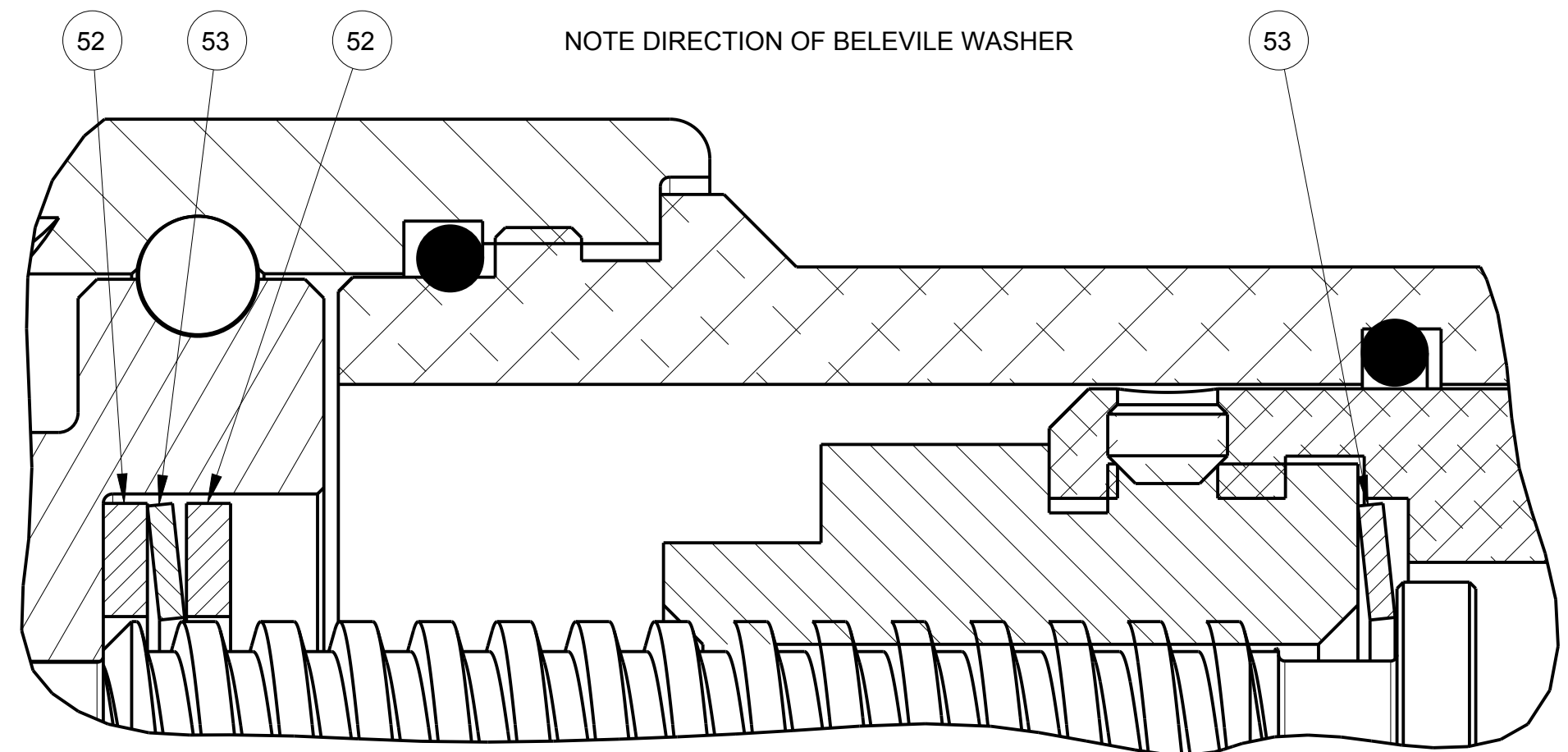

"IMPORTANT"
INSTALLATION INSTRUCTIONS

The Style 3293 has a full time swivel and must be locked in place as follows:
 1. Thread the nozzle onto the monitor outlet.
 2. Rotate the motor into required location.
 3. Tighten the swivel.
 4. Plug in motor connector.
 5. To set gallonage, push in on the baffle head and rotate until desired setting aligns with the roll pin.
 Note: Nozzle may need to be in flush to change to the lowest gallonage.

MAXIMUM OPERATING PRESSURE: 200 PSI
 FLOW RATING: 30-125 GPM AT 100 PSI

WARNING: The electrical control system must incorporate a current limiting circuitry set for a maximum of 3 amps for 12 volts (1.5 amps for 24 volts). Without circuitry set, motor may become inoperable if stalled during operation.

PHONE: 330.264.5678 or 800.228.1161 | FAX: 330.264.2944 or 800.531.7335 | www.akronbrass.com

Parts List Sheet:

122661

WARRANTY AND DISCLAIMER: We warrant Akron Brass products for a period of five (5) years* after purchase against defects in materials or workmanship. Akron Brass will repair or replace product which fails to satisfy this warranty. Repair or replacement shall be at the discretion of Akron Brass. Products must be promptly returned to Akron Brass for warranty service. We will not be responsible for: wear and tear; any improper installation, use, maintenance or storage; negligence of the owner or user; repair or modification after delivery; failure to follow our instructions or recommendations; or anything else beyond our control. WE MAKE NO WARRANTIES, EXPRESS OR IMPLIED, OTHER THAN THOSE INCLUDED IN THIS WARRANTY STATEMENT, AND WE DISCLAIM ANY IMPLIED WARRANTY OF MERCHANTABILITY OR FITNESS FOR ANY PARTICULAR PURPOSE. Further, we will not be responsible for any consequential, incidental or indirect damages (including, but not limited to, any loss of profits) from any cause whatsoever. No person has authority to change this warranty. *Unless otherwise provided herein. Akron Brass industrial electronic components & the Severe-Duty Monitor have a one (1) year warranty. Weldon products have a one (1) year warranty (excluding consumable components). Select Weldon LED products carry a five (5) year warranty. For Weldon product returns call 800-989-2718. Honda products have the manufacturers' warranty and Akron Brass disclaims any warranty in respect of those products.