



607 NW 27th Ave
Ocala, FL 34475
Ph: 352-629-5020 or 1-800-533-3569
Fax : 352-629-290 or 1-800-520-3473

PRODUCT / SERVICE BULLETIN

BULLETIN#	0017
REVISION	E
PAGE	1 OF 2
DISTRIBUTION	<input checked="" type="checkbox"/> INTERNAL <input checked="" type="checkbox"/> EXTERNAL

PRODUCT	FOAMLOGIX 2.1A & 1.7AHP SYSTEMS
SUBJECT	FOAM FLOW SENSOR REPLACEMENT INSTRUCTIONS

1 REPAIR KIT 119348 INCLUDES:

- Foam Flow Sensor (200-2483-00-0)
- Sealing Washer (097-1971-00-0)
- 119376 - Product/Service Bulletin 0017
- 040-0340-00-0 O-RING 2-034 BUNA-N 70 DURO

2 REQUIRED TOOLS:

- 7/16" wrench (2X)
- 5/16" wrench

3 SAFETY INFORMATION

- Remove system power from the Foam system and relieve any trapped pressure.
- Shut off foam tank supply valve.
- Open bypass valve to drain foam lines and use suitable containers to collect residual foam concentrate.
- Protect eyes and skin from foam concentrate per manufacturer's Material Safety Data Sheet or MSDS.

4 REPLACEMENT INSTRUCTIONS

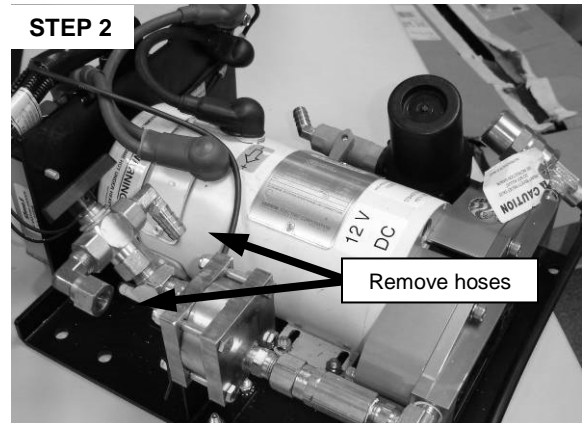
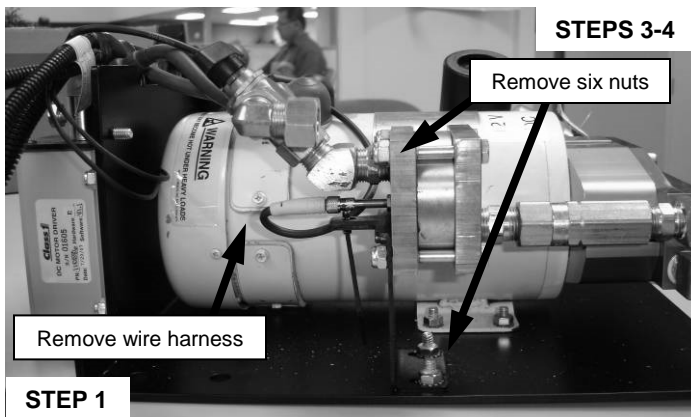

1. Carefully disconnect the wire harness from the old foam flow sensor.
 - Connect the NEW foam flow sensor to the wire harness.
 - Apply system power and verify sensor diagnostic LED is off.
 - Touch end of sensor to brass housing → LED should light.
 - Disconnect the wire harness from the new sensor.
 - Remove system power from the Foam system.
 - (This test verifies that the new sensor is operating correctly.)
2. Disconnect both hoses from the 3-way bypass valve.
3. Remove the four (4) nuts on the brass flowmeter assembly with the two 7/16" wrenches.
4. Remove the two (2) nuts on the bracket bottom with the 7/16" wrench.
5. Remove the sensor side cover of the flowmeter assembly.
 - Inspect o-ring inside the cover for damage or cuts. (2) 040-0340-00-0 O-rings are included, replace as needed.
6. With the 5/16" wrench, loosen the small retaining nut on the foam flow sensor, and unscrew the sensor by hand.
 - Depending on the return instructions provided by the dealer or manufacturer, it may be necessary to return the old sensor. If not, then the old sensor, nut, and seal washer can be discarded.

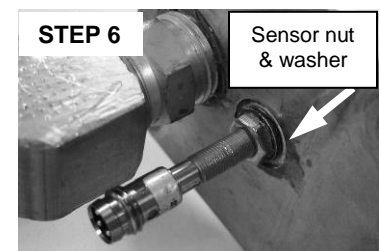
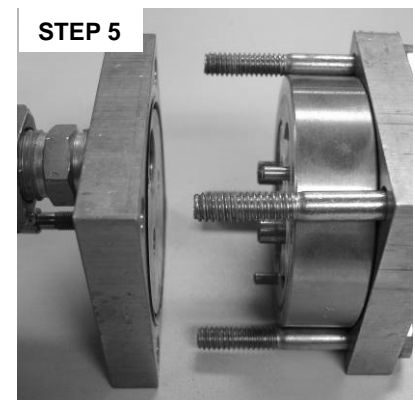



607 NW 27th Ave
 Ocala, FL 34475
 Ph: 352-629-5020 or 1-800-533-3569
 Fax: 352-629-290 or 1-800-520-3473

PRODUCT / SERVICE BULLETIN

BULLETIN#	0017
REVISION	E
PAGE	2 OF 2
DISTRIBUTION	<input checked="" type="checkbox"/> INTERNAL <input checked="" type="checkbox"/> EXTERNAL

PRODUCT	FOAMLOGIX 2.1A & 1.7AHP SYSTEMS
SUBJECT	FOAM FLOW SENSOR REPLACEMENT INSTRUCTIONS

- The foam flow sensor packaging includes two (2) nuts and two (2) lock washers. Only one nut is required for the remaining steps.

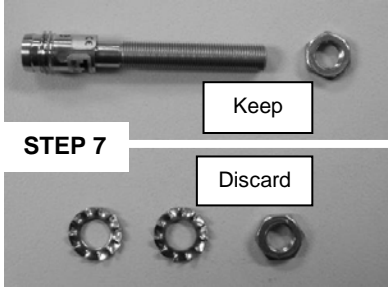

- Thread the new foam flow sensor nut onto the sensor about 1/2" (12mm).
- Thread (do **NOT** push) the new seal washer onto the foam flow sensor about 1/2" (12mm).
 - This seal washer should be silver in color, with a black, rubber seal on the inner diameter.
- Thread the new foam flow sensor into the brass cover by hand, so that the sensor tip is flush with the inside face of the cover.

- DO NOT USE LOCTITE OR THREAD SEALANT ON THE FOAM FLOW SENSOR.
- Use a straight edge or flat object to verify the flush position.
- TIP – When installing the foam flow sensor, it may be easier to lay the brass cover on a flat surface (carefully remove o-ring), and check for flush position after the nut is secure.

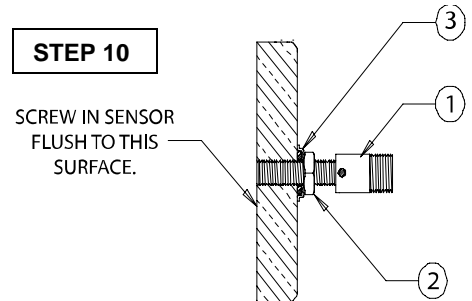

- While holding the new foam flow sensor, lightly tighten the nut with the 5/16" wrench to set the seal washer on the outer face of the cover.
- Verify that the sensor tip is flush with the inner surface and torque the jam nut to a maximum 10.0 in-lb (1.1 N-m).

- Do not bend or over-tighten the sensor.

1	200-2483-00-0	FOAM FLOW SENSOR
2	INCLUDED W/SENSOR	SENSOR NUT
3	097-1971-00-0	SEAL WASHER

- Remove and inspect the two plastic rotors inside the flowmeter assembly for cracks, burrs, etc.
- Inspect the inner housing for debris, metal shavings, etc. and remove as necessary.
- Reinstall both rotors, making sure that each spins freely without binding.



When installed, the flush end of the metal targets in the rotors must face out, toward the foam flow sensor.

- Reinstall the o-ring (if necessary) and reattach the brass cover and the bracket with the six (6) nuts.
 - Tighten all nuts securely and torque to a maximum 6.5 ft-lb (8.5 N-m). Use a criss-cross torque pattern on the four brass housing nuts and bolts.

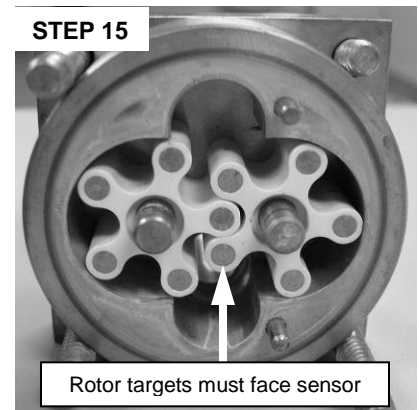

- Reattach foam lines and foam flow sensor harness.
- Apply system power to the Foam system and recalibrate the system per the user manual instructions.

REV	DATE	BY	DESCRIPTION
D	10/06/11	AJG	ADJUSTED INSTRUCTIONS TO USE 122670 ASSEMBLY
E	1/15/16	JDF	REV D IS FOR 122670; THIS WORK INSTRUCTION MAKES 119348 LIVE AGAIN.
F	1/15/16	JDF	ADDED 040-0340-00-0 O-RING