



STYLE 8840 HI CYCLE ELECTRIC VALVE INSTRUCTIONS AND PARTS LIST

GENERAL INFORMATION

The Style 8840 Valve utilizes a flat ball concept providing an open area greater than a typical 4" waterway. This design features a 4" long body and has easy operation with limited friction loss.

The valve has the Swing-Out™ feature and is designed for easy service with only one seat and an aluminum bronze flat ball which will rarely need to be changed.

The valve has a rated working pressure of 250 PSI in the flow direction, but will hold 100 PSI in the reverse direction. It is hydrostatically rated at 500 PSI.

This valve is single directional and must be installed with the 250 PSI directional arrow (cast on valve body) pointing away from the pump regardless if it is for discharge or intake applications.

NOTE: If the valve is used as an intake, it must be installed with the 250 psi directional arrow towards the swivel intake.

The electric actuator is reduced to 25:1 and will travel from full open to full close in approximately 8-10 seconds.

INSTALLATION

1. Plumb into the pump system as usual being sure to heed the flow directional arrow cast on the body.
2. The actuators can be mounted in one of four positions.
3. Keep the piping aligned so undue stresses are not placed on the valve. Victaulic connections in lieu of pipe threads do help.
4. Be sure the white flange seal rings are in place before installing the valve. Close the flat ball before attaching flanges to body.
5. Snug up flange bolts alternately (not adjacently) when securing flanges to valve body. Tighten each to 60-70 foot pounds. (Also alternately)
6. Electric actuators should be installed in a direction where the manual override is accessible.
7. If any welding is to be done on the truck, disconnect electrical connections until welding is finished.

NOTE: If the actuators are removed for repositioning, always use Loctite 222 or Permabond LM113 on the mounting screws.

NOTE: Pressures over 100 psi in the direction opposite to the arrow cast into the body could allow a small volume of water to pass through the valve on the upstream side. Back pressures up to 250 psi, will not affect the valve seating system or fire pump.

PRESSURE TRANSDUCER

Use a thread seal and tighten only until snug plus an extra 1/8 to 1/4 turn. Over tightening of the metal fitting may cause a slight zero shift.

CAUTION: Reverse excitation will permanently damage the unit. Follow the wiring instructions carefully.

TANK FILL CONTROLLER DIP SWITCH SETTINGS

SWITCH 1	SWITCH 2	SWITCH 3	RELATIVE WATER LEVEL (INCHES)
Down	Down	Down	+2.0
Up	Down	Down	+1.0
Down	Up	Down	Factory Default
Up	Up	Down	-1.0
Down	Down	Up	-2.0
Up	Down	Up	-3.0
Down	Up	Up	-4.0
Up	Up	Up	-5.0

SWITCH 4	SWITCH 5	WATER LEVEL DEAD ZONE (INCHES)
Down	Down	0.5
Up	Down	1.0
Down	Up	1.5
Up	Up	2.5*

SWITCH 6	LEVEL CHANGE SENSITIVITY
Down	High
Up	Moderate*

SWITCH 7	SWITCH 8	RAPID LEVEL CHANGE COMPENSATION
Down	Down	Low
Up	Down	Moderate*
Down	Up	High
Up	Up	Very High

THEORY OF OPERATION

The Auto Tank Fill System uses a motor controlled valve to regulate the water height in a tank. Variable flow rates are accommodated for both the incoming water supply and the discharge water usage. A pressure transducer in the logic box measures the water height in the tank and the rate of rise or fall of the water level to determine the direction that the valve must be moved in order to maintain a constant water level in the tank.

The Auto Tank Fill System divides the tank into three regions: (1) The Water Level Dead Zone, (2) Any level above the dead zone, and (3) Any level below the dead zone. The top of the Water Level Dead Zone is called the Set Point. The depth of the Water Level Dead Zone, i.e., the depth of the layer descending below the Set Point is determined by Switch 4 and Switch 5 of the Printed Circuit Board (PCB) DIP switch. The factory level default for the Water Level Dead Zone layer is 2.5 inches. The height in the tank for the Set Point, and hence the top of the Water Level Dead Zone, is set at the factory. The Set Point may be moved relative to the factory setting with the use of Switches 1-3 of the PCB DIP switch.

A software program contained in the logic box is used for regulating the depth of the water in the tank. The logic in the program is as follows:

1. If the water level in the tank is above the set point, the controller moves the motorized valve in the closed direction. As long as the water level stays above the set point, the controller continues to close the valve until a micro switch is activated just shy of the hard stop at the fully closed position. If the valve activates the micro switch for longer than 5 seconds and the water level continues to rise, the valve will fully close to the hard stop.
2. If the water level in the tank is below the bottom of the Water Level Dead Zone, the controller moves the valve in the open direction. As long as the water level stays below the bottom of the dead zone, the controller continues to open the valve until a micro switch is activated just shy of the hard stop at the fully open position. If the valve activates the micro switch for longer than 5 seconds and the water level continues to fall, the valve will fully open to the hard stop.
3. If the water level in the tank is within the Water Level Dead Zone, the controller shuts off the motor on the valve. This causes the valve to remain throttled at whatever position it was in just before the water level in the tank moved into the dead zone.

tank moved into the

- The software program is set to compensate for rapidly changing water levels. If the water level in the tank is rising rapidly due to a high inflow and little or no discharge, the controller anticipates the need to start closing the valve prematurely and does so to prevent overflow of the tank. In a similar fashion, if the water level in the tank is falling rapidly due to a high discharge rate, coupled with an insufficient inflow, the controller will begin to open the valve prematurely in an effort to keep the water level in the tank within the dead zone.

Switch 6 of the PCB DIP switch selects the controller's sensitivity to water level changes and affects how item 4 above modifies the basic regulation algorithm. The High setting for this switch causes the controller to react very quickly to changing water levels. This causes more wear on the valve components because the valve changes direction most often at this setting.

The Rapid Level Change Compensation controlled by switches 7 and 8 on the PCB DIP switch also affects the controller's response to changing water levels. The Rapid Level Change Compensation determines how strongly the basic algorithm is modified once a changing water level is detected. This setting also affects the wearing of the valve components. The higher the compensation level is set, the more tightly the water level in the tank is controlled, even with large unequal inflow and discharge rates. However, the cost of this tighter regulation is more wear on the valve components as the controller continuously adjusts the valve to meet changing conditions within the tank.

The controller has the ability to activate an external no-voltage-input counter using the "closed" micro switch as a trigger. When the "closed" micro switch is activated, a set of dry relay contacts will close. When the switch is deactivated, the relay contacts open back up. These contacts have no voltage on them and are available at the "INPUT SWITCHES AND COUNTER" connector, terminals A and E.

The PCB inside the logic box has a red and a green LED that is used to indicate the various operating conditions of the valve. External LEDs can be plugged into the logic box at the LEDs connector and will duplicate the function of the on-board LEDs. The current-limiting resistors are built onto the board so ordinary 2-volt LEDs should be used. The following table describes the LED behavior during valve operation.

LED STATUS	VALVE OPERATING CONDITION
Solid Red	Valve is fully closed against the hard stop
Quickly Blinking Red at 5 times a second	Valve is closing
Slowly Blinking Red at once a second	Valve is stopped at the micro switch just shy of the closed hard stop
Solid Green	Valve is fully open against the hard stop
Quickly Blinking Green at 5 times a second	Valve is opening
Slowly Blinking Green at once a second	Valve is stopped at the micro switch just shy of the open hard stop
Solid Red and Solid Green	Valve is stopped somewhere between the open and closed micro switches
No Red and No Green	No power to the logic box

OPERATING INSTRUCTIONS

Please read the following instructions completely before applying power to the Auto Tank Fill System.

- Make sure all connectors are plugged in and connected properly.
- Place the Enable/Close switch in the Close position.
- Apply power to the Auto Tank Fill System.
- About 1 second after power is applied to the system, the Controller will close the Tank Fill valve. Power to the valve motor is automatically removed when the valve reaches the closed position. If the valve is already closed at power up, the controller will detect this condition.
- If the Tank Fill Valve has responded correctly to item 4 above, move the Enable/Close switch to the Enable position. This is the position for normal operation of the Auto Tank Fill System. If the tank is empty, the controller will immediately begin to open the Tank Fill Valve. If the valve is already at the fully open position, the controller will maintain the valve in that position. If the tank is full of water, the controller will close the Tank Fill Valve. If the valve is already closed, the controller will maintain the valve in this position.

TROUBLESHOOTING

The following instructions may prove helpful in troubleshooting the Auto Tank Fill System:

Tank Fill Valve Does Not Operate

- Make sure power is applied to the Auto Tank Fill System.
- Place the Enable/Close switch in the closed position for at least 5 seconds.

3. Unplug the pressure transducer cable from the logic box and plug in the Valve Switch Tester.
4. Use the Open/Close switch on the Valve Switch Tester to make sure that the valve does not operate while the Enable/Close switch is in the Close position.
5. Change the position of the Enable/Close switch to the Enable position. Use the Open/Close switch on the Valve Switch Tester to see if the valve operates. It takes about 5 seconds for the valve to move between the open and closed position. The motor can be heard when it is operating the valve. If the motor runs, the Logic Box is correctly monitoring the Enable/Close switch and sending power to the valve motor. If the motor runs but the valve does not open and close in response to changes in the Open/Close switch on the Valve Switch Tester, then the valve actuator is faulty and must be replaced.
6. If the valve motor does not respond to changes in the Enable/Close switch, check the connection of the Enable/Close switch cable to the connector at the logic box.

Tank Overflows Occasionally

1. Adjust the Rapid Level Change Compensation setting from Moderate to High or Very High by changing switches 7 and 8 of the PCB DIP switch.
2. If the Rapid Level Change Compensation is not sufficient to keep the tank from overflowing, adjust the Relative Water Level downward to lower the overall level of water in the tank. This will cause the valve to begin closing earlier and may be sufficient to keep the tank from overflowing.

Tank Fill Valve Does Not Shut Off - Tank Overflows

1. Make sure the Tank Fill Valve is operating properly.
2. If the Tank Fill Valve is operating properly, the problem is most likely in the pressure transducer or with the connection of the transducer to the Logic Box.
3. Make sure the cable from the Transducer to the Logic Box is in good shape and the Transducer connector is correctly mated with its receptacle.
4. Replace the pressure transducer if the problem persists.

Tank Fill Valve Does Not Open - Tank Remains Empty

1. Make sure the Tank Fill Valve is operating properly.
2. If the Tank Fill Valve is operating properly, the problem is most likely in the pressure transducer or with the connection of the transducer to the Logic Box.
3. Make sure the cable from the Transducer to the Logic Box is in good shape and the Transducer connector is correctly mated with its receptacle.
4. Replace the pressure transducer if the problem persists.

Tank Overflows When Filled Rapidly with No Discharge

1. This condition can occur when a very high inflow is accompanied with little or no discharge.
2. Adjust the Rapid Level Change Compensation setting from Moderate to High or Very High by changing switches 7 and 8 of the PCB DIP switch.
3. If the Rapid Level Change Compensation is not sufficient to keep the tank from overflowing, adjust the Relative Water Level downward to lower the overall level of water in the tank. This will cause the valve to begin closing earlier and may be sufficient to keep the tank from overflowing.
4. As a last resort, move the Level Change Sensitivity to High with switch 6 of the PCB DIP switch.

Water Level in the Tank Varies Too Much

1. The water level in the tank can be expected to vary by more than the Water Level Dead Zone height. This is because the valve motor only starts to change the valve position when the water level is either above or below the boundaries of the Water Level Dead Zone. In the time it takes the valve to move to a position to compensate for the rising or falling level, additional water enters or leaves the tank.
2. Adjust the Water Level Dead Zone height using switches 4 and 5 of the PCB DIP switch. The factory default was chosen to minimize wear on the valve components. As the dead zone depth is made smaller, the valve will work harder since the water level in the tank will only be in the dead zone for a short time.

Test Procedure for Checking Switch Operation in Akron Brass Tank Fill Valve

Tools Required

- #2 Phillips head screwdriver for removing and securing the lid of the logic box
- Voltmeter for measuring system voltages
- Valve Switch Tester

Setup

1. Make sure that the logic box is powered down.
2. Remove the lid of the logic box. If the gasket becomes separated from the lid, carefully press the gasket back into the lid.
3. Unplug the pressure transducer from the logic box.
4. Plug the tester into the logic box at the PRESSURE TRANSDUCER Connector.
5. Position the switch on the tester to the "CLOSE" position.

Testing

- Note: when measuring voltages at terminal block TB3, properly locate TB3 as the section of the green terminal blocks that faces the black terminal block TB2 where the incoming power is connected. Reference the wiring diagram on the inside of the lid of the logic box.
- Switch Source Voltage
 1. Power up the logic box. If not already closed, the valve will move towards the closed position.
 2. Measure the voltage at terminal TB3-28 with respect to system ground (terminal TB2-3). It should be about 1 volt below the incoming system voltage at TB2-2. Note: the voltage at this terminal is 2 diode drops below the incoming system voltage.
- "Opened" Switch
 1. Move the switch on the tester to the "OPEN" position.
 2. The green LED on the circuit board will blink rapidly at 5 times a second, indicating that the valve is opening. When the "Opened" switch is activated by the sector gear, the LED will blink slowly at once a second. Normally, the valve will stay in this position but after 5 seconds, the valve may open to the hard stop, depending on the accuracy of the analog-to-digital converter in converting the least significant bit.
 3. Measure the voltage at terminal TB3-27. It should be about 16 volts indicating that the "Opened" switch is activated. Note: the voltage at this terminal is about 60% of the voltage at terminal TB3-28. This is due to a voltage divider formed by the external 1k Ω resistor and a 1.5k Ω resistor on the board.
 4. Measure the voltage at terminal TB3-26. It should be 0 volts indicating that the "Closed" switch is not activated.
- "Closed" Switch
 1. Move the switch on the tester to the "CLOSE" position.
 2. The red LED on the circuit board will blink rapidly at 5 times a second, indicating that the valve is closing. When the "Closed" switch is activated by the sector gear, the LED will blink slowly at once a second. Normally, the valve will stay in this position but after 5 seconds, the valve may close to the hard stop, depending on the accuracy of the analog-to-digital converter in converting the least significant bit.
 3. Measure the voltage at terminal TB3-26. It should be about 16 volts indicating that the "Closed" switch is activated. Note: the voltage at this terminal is about 60% of the voltage at terminal TB3-28. This is due to a voltage divider formed by the external 1k Ω resistor and a 1.5k Ω resistor on the board.
 4. Measure the voltage at terminal TB3-27. It should be 0 volts indicating that the "Opened" switch is not activated.

Troubleshooting

- Switch source voltage is not close to incoming system voltage (within 1-2 volts)
 1. Switch source voltage may be shorted to ground either directly or indirectly. Remove the cable from the TANK FILL VALVE SWITCHES Connector and check the voltage again. If the voltage is still incorrect, remove the cable from the INPUT SWITCHES AND COUNTER Connector and check the voltage again. If the voltage is still incorrect, remove the cable from the PRESSURE TRANSDUCER Connector and check the voltage again. If it is still incorrect, replace the circuit board.
 2. If unplugging one of the cables corrected the voltage reading, then trace out the wiring for that cable and attempt to find the short circuit. If the cable from the TANK FILL VALVE SWITCHES Connector seems to be at fault, also check to make sure that the wires inside the logic box between the TANK FILL VALVE SWITCHES Connector and terminal block TB3 are wired Correctly

- “Opened” switch does not appear to be working
 1. Check the wiring to make sure that voltage is going out to the switch and that the return from the switch is going into terminal TB3-27. Make sure that the wiring has not been crossed with the “Closed” switch wiring, either in the external cable or in the logic box.
 2. Make sure that the switch is being activated by the sector gear.
- “Closed” switch does not appear to be working
 1. Check the wiring to make sure that voltage is going out to the switch and that the return from the switch is going into terminal TB3-26. Make sure that the wiring has not been crossed with the “Opened” switch wiring, either in the external cable or in the logic box.
 2. Make sure that the switch is being activated by the sector gear.

MAINTENANCE

After 80,000 cycles or every 56 weeks, whichever comes first, the following Maintenance needs to be performed:
An Akron Style 9167 must be used to rebuild the valve. Complete instructions are included with each kit.

WARRANTY

All components of the Hi Cycle Valve carry a one (1) year Akron Brass warranty provided the maintenance instructions outlined above are followed.

Logic Box Assembly

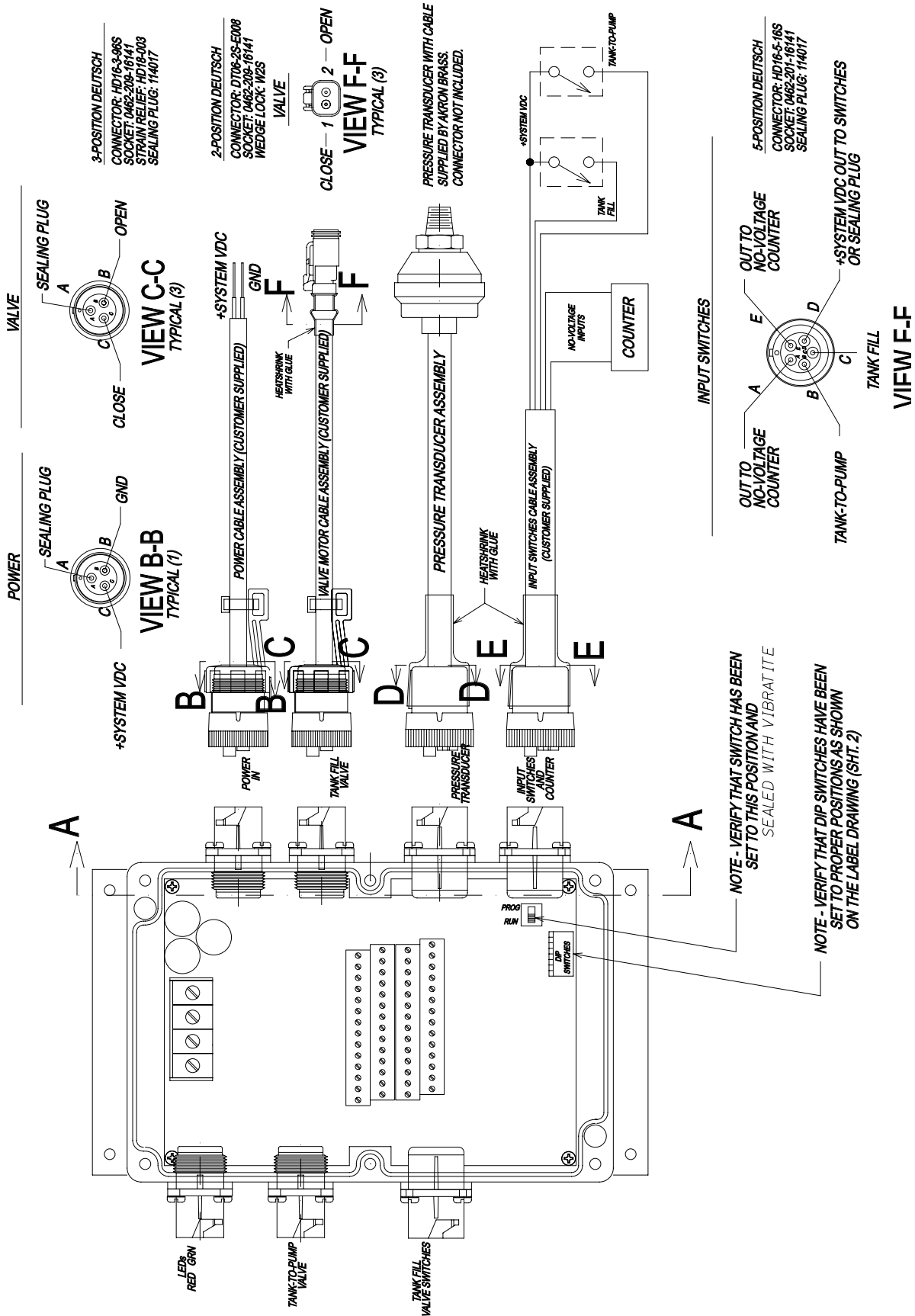

Logic Box Assembly

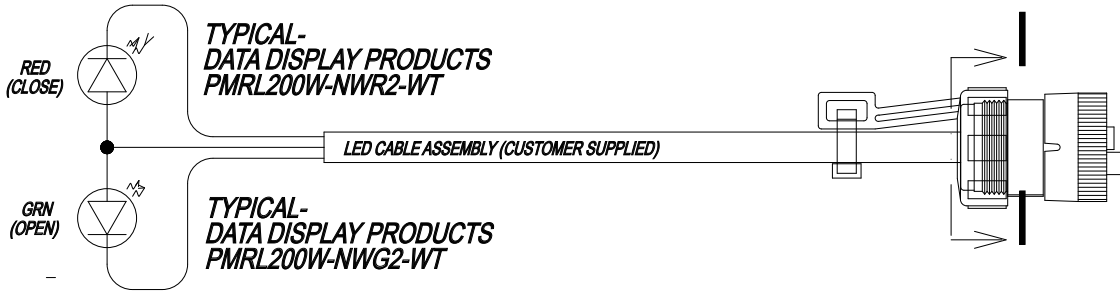

LEDs

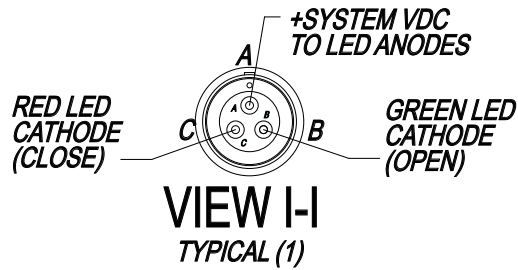

VIEW A-A

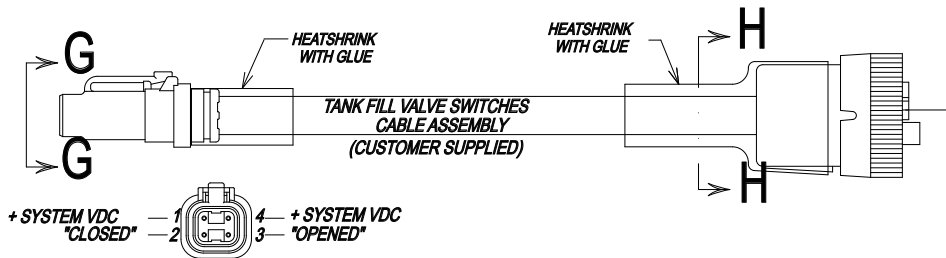

VIEW G-G

4-POSITION DEUTSCH
CONNECTOR: DTM06-4S-E007
SOCKET: 0462-201-20141
WEDGE LOCK: WM-4S

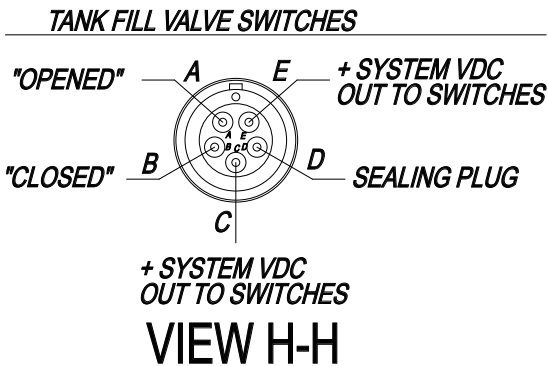

PRESSURE TRANSDUCER

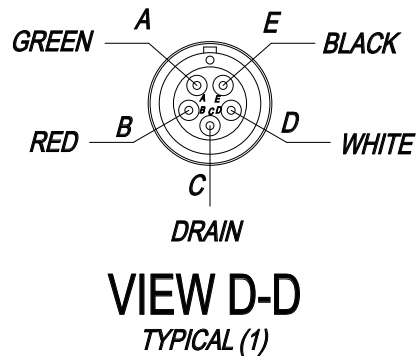

Wiring Diagram

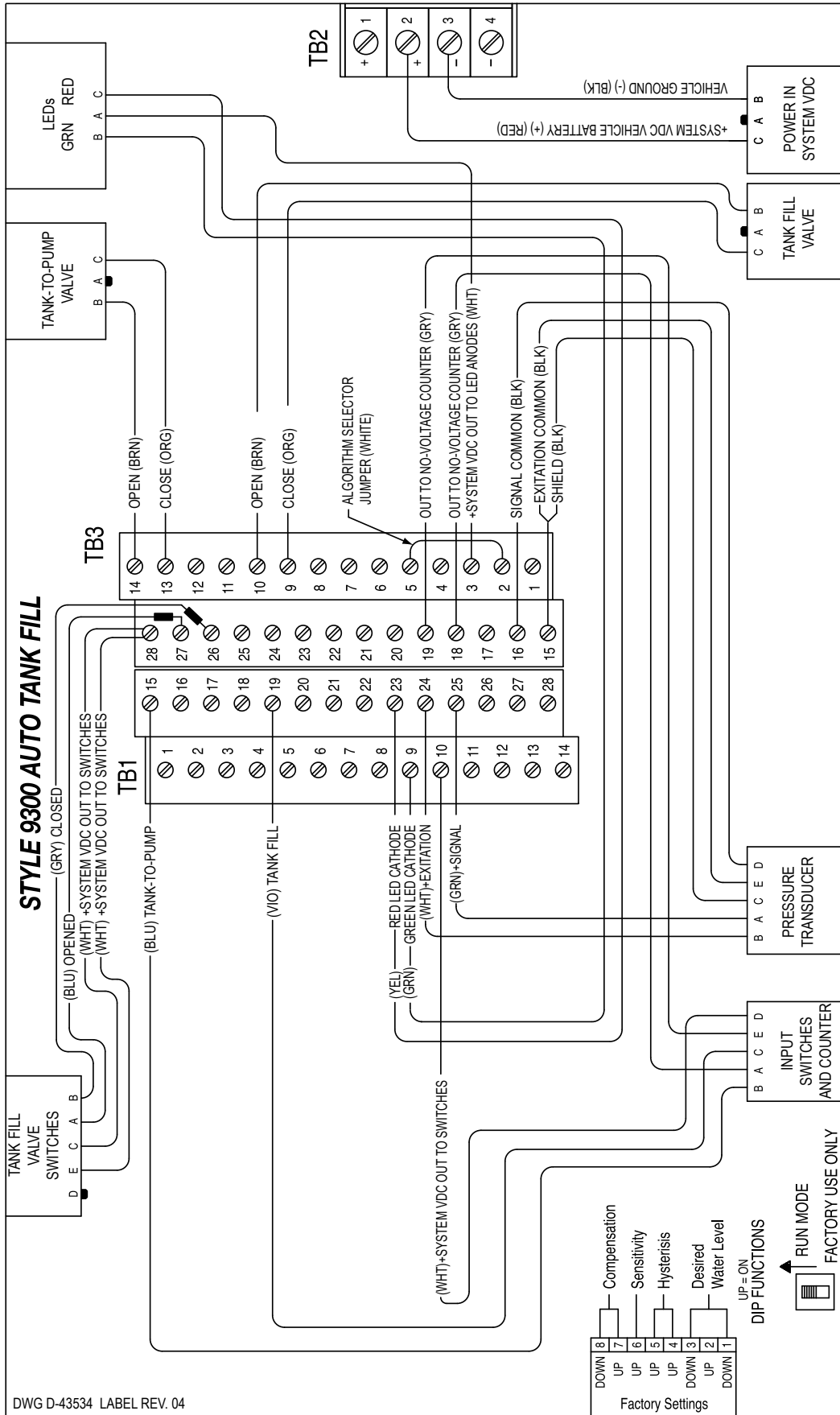

Electric Valve Diagram

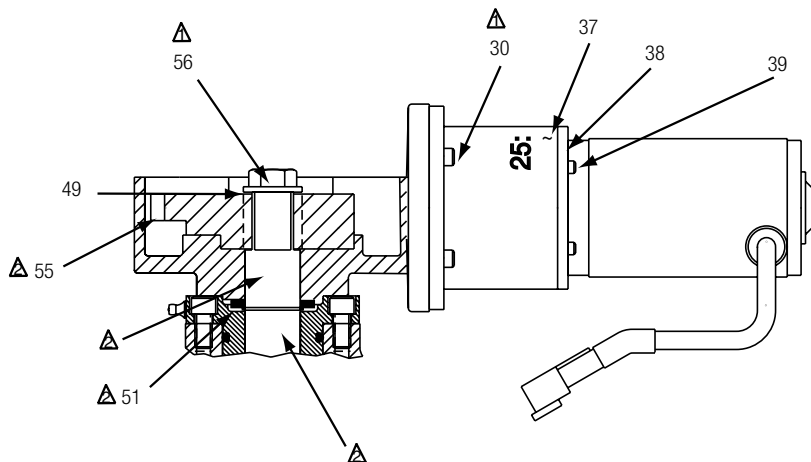
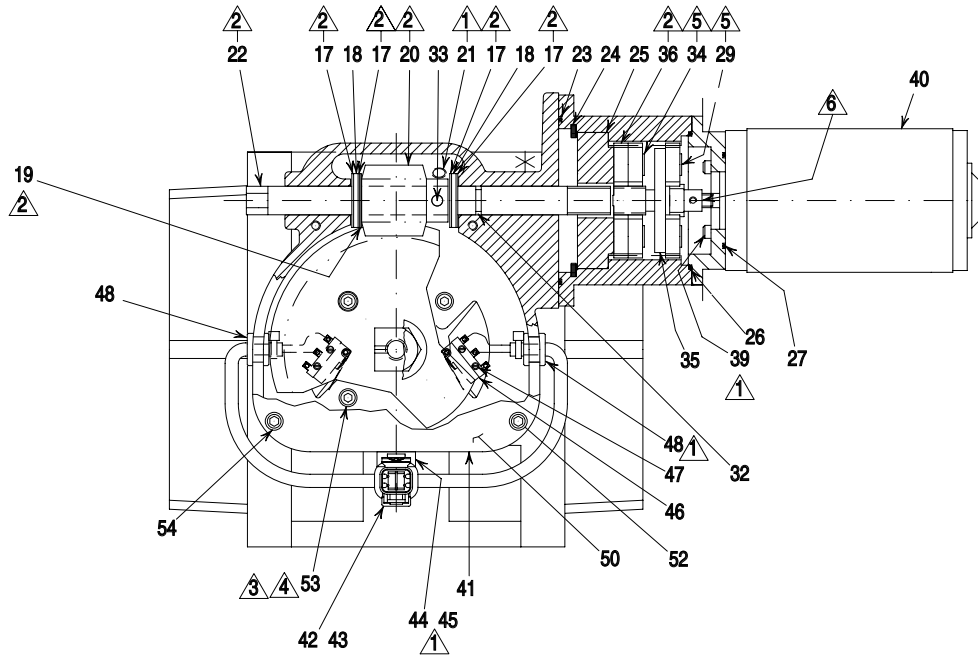
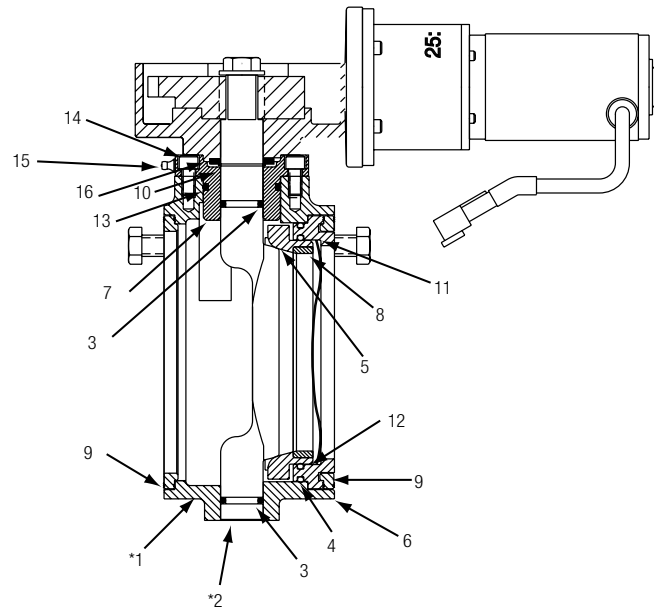

ASSEMBLY NOTES:

- USE PARKER-O-LUBE ON ALL O-RINGS AND ALL MATING SURFACES.
- ▲ USE PERMABOND LM113 OR LOCTITE 222
- ▲ USE TRIBOLUBE 23.
- ▲ USE PRIMER-T
- ▲ USE PERMABOND HH120 OR LOCTITE 227
- ▲ OIL DIP
- ▲ USE LOCTITE 680
- * GREASE TOP & BOTTOM OF TRUNNION SHAFT AND MATING BODY SURFACES. USE TRIBOLUBE 23

Electric Valve Parts List

ITEM NO.	DESCRIPTION	PART NUMBER	QUANTITY
1	Valve Body	118153	1
2	Flat Ball	118154	1
*3	O-Ring	757226	2
*4	O-Ring	757338	1
*5	Seat	769797	1
6	Seat Retainer	118156	1
**7	Trunnion Bushing (Pre 2008)	118157	1
** 7	Trunnion Bushing (2008)	121608	1
8	Seat Ring	118158	1
*9	Flange Seal	768309	2
10	Retaining Ring	758185	1
11	Wavy Spring	784138	1
*12	O-Ring	757371	1
13	O-Ring	757006	1
14	Screw 5/16 - 18	767016	4
15	Grease Fitting	713034	1
16	Thrust Washer	784104	1
*17	Thrust Washer	784111	4
*18	Needle Bearing	703453	2
*19	Thrust Washer	784103	1
*20	Worm Gear	106611	1
21	Grease Fitting	713034	1
*22	Drive Shaft	769510	1
23	O-Ring	757263	1
24	Retaining Ring	758172	1
25	Carrier Plate ††	742118	1
26	O-Ring	757280	1
27	O-Ring	757056	1
29	Short Rivet	754052	3
30	Socket Head Screw	763038	4
*32	O-Ring	757282	1
*33	Groove Pin	741058	1
34	Long Rivet	754062	3
35	Carrier Plate †	744388	1
ITEM NO.	DESCRIPTION	PART NUMBER	QUANTITY
36	Planet Gear	718165	9
37	Speed Reducer Housing	120414	1
38	Motor Face Plate	745165	1

39	Socket Head Screw	765052	8
40	Motor Assembly-24 volt	88400674	1
**41	Gear Housing (Pre 2008)	120549	1
** 41	Gear Housing (2008)	121609	1
42	Deutsch Receptacle	758267	1
43	Deutsch Wedge	784162	1
44	Deutsch Bracket Connector	704589	1
45	Phillips Screw	765208	1
46	Switch Assembly	769787	2
47	Screw	765248	4
48	Rubber Grommet	718256	2
49	Washer	784068	1
50	Cover Plate	743003	1
51	Thrust Washer	784104	1
52	Socket Head Screw	765155	4
**53	Socket Head Screw (Pre 2008)	767086	4
**53	Socket Head Screw (2008)	765030	4
54	Washer	784123	4
*55	Sector Gear	121330	1
56	Screw 1/2-13	761065	1

* Parts included in field service kit - Style 9167
 ** Valves manufactured after 6/08 use a larger Screw (#53). This change affects the Trunnion Bushing (#7) and Gear Housing (#41).
 † Carrier plate subassembly replacement part #88400839 (items 35, 29, 36)
 † † Carries plate subassembly replacement part #88400838 (items 25, 34, 36)
 Subassembly includes carrier plate with gears & rivets attached



PHONE: 330.264.5678 or 800.228.1161 | FAX: 330.264.2944 or 800.531.7335 | akronbrass.com

REVISED: 04/16

WARRANTY AND DISCLAIMER: We warrant Akron Brass products for a period of five (5) years after purchase against defects in materials or workmanship. Akron Brass will repair or replace product which fails to satisfy this warranty. Repair or replacement shall be at the discretion of Akron Brass. Products must be promptly returned to Akron Brass for warranty service.

We will not be responsible for: wear and tear; any improper installation, use, maintenance or storage; negligence of the owner or user; repair or modification after delivery; damage; failure to follow our instructions or recommendations; or anything else beyond our control. WE MAKE NO WARRANTIES, EXPRESS OR IMPLIED, OTHER THAN THOSE INCLUDED IN THIS WARRANTY STATEMENT, AND WE DISCLAIM ANY IMPLIED WARRANTY OF MERCHANTABILITY OR FITNESS FOR ANY PARTICULAR PURPOSE. Further, we will not be responsible for any consequential, incidental or indirect damages (including, but not limited to, any loss of profits) from any cause whatsoever. No person has authority to change this warranty.

© Akron Brass Company, 2000 All rights reserved. No portion of this can be reproduced without the express written consent of Akron Brass Company.