

STYLE 9137

USE THESE ILLUSTRATIONS TO IDENTIFY THE VARIOUS PARTS IN THIS KIT.



P/N 7-57-022
Threaded Trunnion O-Ring (15)



P/N 7-57-054
Handle Trunnion
O-Ring (6)



P/N 7-57-284
Handle Trunnion
O-Ring (6)



P/N 7-57-226
Handle Trunnion
O-Ring (12)



P/N 7-57-010
Ball Trunnion O-Ring (12)

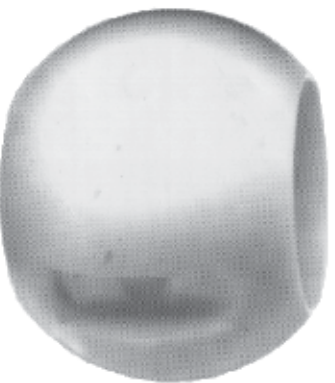

P/N 7-03-124
Valve Ball (19)



P/N 7-69-180
Valve Seat (20)



AKRON
BRASS COMPANY

Tested--Proven--Trusted.

ISO 9001 REGISTERED COMPANY

PHONE: 330.264.5678 or 800.228.1161 | FAX: 330.264.2944 or
800.531.7335 | akronbrass.com REVISED: 7/11

WARRANTY AND DISCLAIMER: We warrant Akron Brass products for a period of five (5) years after purchase against defects in materials or workmanship. Akron Brass will repair or replace product which fails to satisfy this warranty. Repair or replacement shall be at the discretion of Akron Brass. Products must be promptly returned to Akron Brass for warranty service.

We will not be responsible for wear and tear; any improper installation, use, maintenance or storage; negligence of the owner or user; repair or modification after delivery; damage; failure to follow our instructions or recommendations; or anything else beyond our control. **WE MAKE NO WARRANTIES, EXPRESS OR IMPLIED OTHER THAN THOSE INCLUDED IN THIS WARRANTY STATEMENT, AND WE DISCLAIM ANY IMPLIED WARRANTY OF MERCHANTABILITY OR FITNESS FOR ANY PARTICULAR PURPOSE.** Further, we will not be responsible for any consequential, incidental or indirect damages (including, but not limited to, any loss of profits) from any cause whatsoever. No person has authority to change this warranty.

© Akron Brass Company 2011 All rights reserved. No portion of this can be reproduced without the express written consent of Akron Brass Company.



AKRON
BRASS COMPANY

STYLE 9137 FIELD SERVICE KIT FOR 7620/7820 2" SWING-OUT™ VALVE





AKRON
BRASS COMPANY

**STYLE 9137
FIELD SERVICE KIT
FOR 7620/7820
2" SWING-OUT™ VALVE**

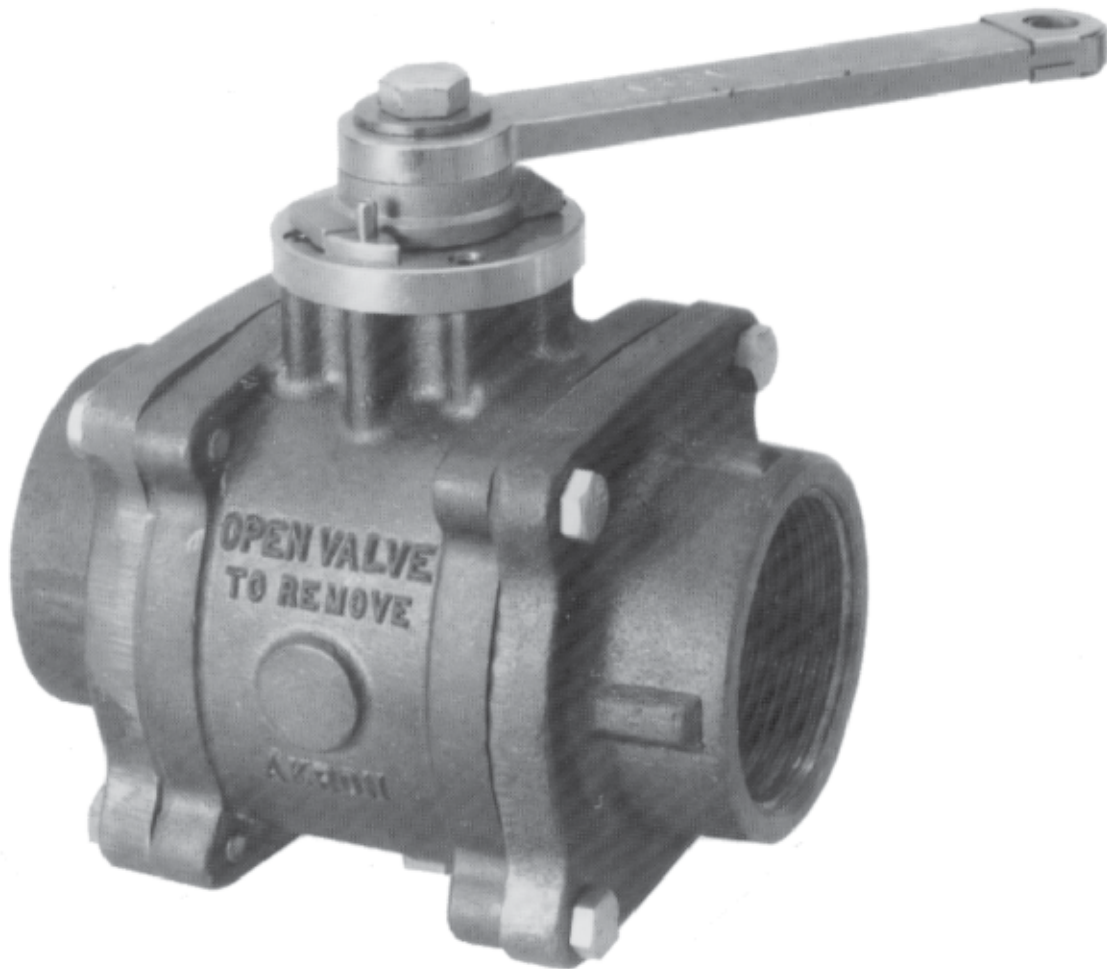

For assistance or further information, please contact the Technical Service Dept: 1-800-228-1161
Akron Brass Co., P.O. Box 86, Wooster, Ohio 44691, (330) 264-5678, FAX # (330) 264-2944
Akron Manufacturing Co., P.O. Box 280, Aylmer, Ontario, N5H 2R9, (519) 773-8431, FAX # (519) 773-3794

Style 7620
Non Tork-Lok®
with Trunnion Retaining
Plate (#7)

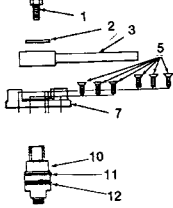

Style 7820
Tork-Lok with
large stops built into
Trunnion Retaining
Plate (#7)

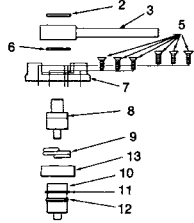

Style 7620
Non Tork-Lok with stops
in valve body and
separate stop
plate (#4)

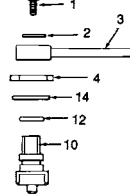

Style 7820
with separate stop
plate (#4)

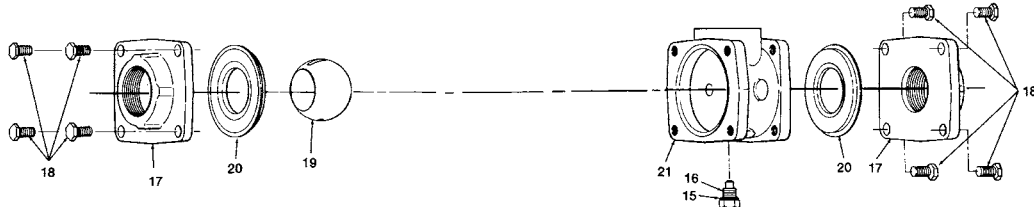
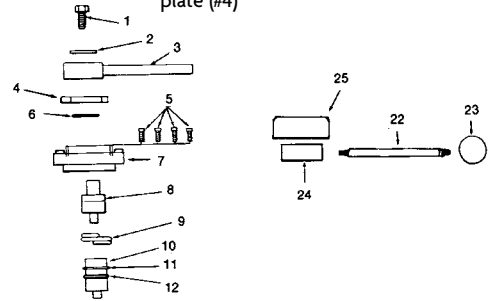

ITEM NO	DESCRIPTION	7620 with Trunnion Plate	7820 with Stops in Trunnion Plate	7620 with Separate Stop Plate	7820 with Separate Stop Plate
1	Handle Bolt	7-61-065	7-61-065	7-61-065	7-61-065
2	Handle Washer	7-84-034	7-84-034	7-84-034	7-84-034
3	Handle*				
4	Stop Plate RI Hdle	N/A	N/A	7-42-095	7-42-095
4	Stop Plate TS Hdle	N/A	N/A	N/A	7-42-073
5	Trunnion Plate Screws	7-67-090 (6)	7-67-090 (6)	N/A	7-65-028 (4)
6	Handle O-Ring	N/A	7-57-054	N/A	7-57-284
7	Trunnion Retaining Plate	105707	**	N/A	7-42-089
8	Handle Trunnion	N/A	7-72-092	7-72-115	7-72-142
9	Tork-Lok Spring	N/A	7-68-210	N/A	7-68-210
10	Ball Trunnion	7-72-088	7-73-149	7-72-115	7-73-149
11	Retaining Ring	7-58-058	7-58-058	N/A	7-58-154
12	Trunnion O-Ring	7-57-010	7-57-010	7-57-226	7-57-010
13	Tork-Lok Sleeve	N/A	7-69-172	N/A	N/A
14	7600 Handle Spacer	N/A	N/A	7-69-310	N/A
15	Threaded Trunnion O-Ring	7-57-022	7-57-022	7-57-022	7-57-022
16	Threaded Trunnion	7-73-094	7-73-094	7-73-094	7-73-094
17	Complete Adapters*				
18	Adapter Bolts (8)	7-61-016	7-61-016	7-61-016	7-61-016
19	Ball	7-03-124	7-03-124	7-03-124	7-03-124
20	Seats (2)	7-69-180	7-69-180	7-69-180	7-69-180
21	Valve Body	105286	105286	105286	106309
22	TS Handle Rod — 9 1/4"	N/A	109146	N/A	109146
23	TS Handle Ball	N/A	7-03-080	N/A	7-03-080
24	TS Handle Hub	N/A	7-21-278	N/A	7-21-278
25	TS Handle Cover	N/A	109177	N/A	109177

*See Price List for complete handles and adapters. ** Replace with Tork Lok Conversion Kit

INSTRUCTIONS FOR INSTALLING THE PARTS IN THIS KIT

DISASSEMBLY—BALL AND SEATS

Note: This kit includes extra O-rings for the different variations of valve. Identify the correct replacement O-rings when removing the old ones.

1. Turn the valve to the open position.
2. If the valve can be rotated out of line, remove three pairs of adapter bolts (18) and loosen the fourth pair. Swing the valve out of the line. If the valve cannot be rotated out of line, remove all eight adapter bolts and take the valve out completely.

Note: If it is necessary to remove the handle, mark the position of the handle in relation to the ball position, and the orientation of the stop plate (4) if so equipped.

3. Remove the two seats (20) from the valve body (21). It may be necessary to partially close the ball and grasp the inside lip of the seat.
4. Remove the threaded trunnion (16). If necessary, use fine emery paper to clean up the smooth portion that fits into the ball. The ball should fit loosely on the trunnion.
5. Rotate the handle so that the slot in the top of the ball is parallel to the waterway. Remove the ball (19).

DISASSEMBLY—HANDLE AND TOP TRUNNION(S)

Note: If the valve is equipped with an electric actuator, do not disassemble this portion of the valve. The water tight seal will be broken and water may leak into the electronic controls chamber. If the valve is equipped with a standard type handle, it is not normally necessary to replace the O-ring under the handle or on the ball trunnion.

Do not disassemble this portion of the valve unless there is a leak.

1. Remove the handle bolt (1) and washer (2).
2. Note the position of the handle relative to the groove in the top of the trunnion for reassembly purposes. Remove the handle (3) and the stop plate (4), handle O-ring (6) and handle spacer (14) if so equipped.
3. If the valve includes a trunnion retaining plate (7), note the position for reassembly purposes. Remove the trunnion plate screws (5).

Note: With flat head screws, one screw may be tighter than the others. Try to loosen all remaining screws before using excessive force on one.

If the valve does not have a retaining plate, remove the trunnion (10) by pushing it into the valve body.

4. Remove the trunnion retaining plate (7). If this plate was secured with socket head screws, the handle trunnion (8) should remain in the plate.
 5. Remove the handle trunnion (8), if separate.
 6. Remove the Tork-Lok® sleeve (13) and spring (9) subassembly if applicable.
- Caution:** Do not remove the spring from inside the sleeve.
7. Remove the ball trunnion (10) by pushing it from the inside of the valve.

REASSEMBLY—HANDLE AND TOP TRUNNION(S)

Note: Lubricate all O-rings with Parker O-Ring Lube or equivalent petroleum-based lubricant.

1. Replace the O-ring (12) on the ball trunnion (10) and reinstall the trunnion in the valve body.
2. Replace the Tork-Lok sleeve (13) and spring (9) subassembly and handle trunnion (8) if so equipped.

Note: The ears of the Tork-Lok spring must be aligned with the corresponding recess of the ball trunnion. The pilot shaft of the handle trunnion must fit into the hole in the center of the ball trunnion.

3. Reposition the trunnion retaining plate (7), if so equipped, and install the screws (5).

Note: For Tork-Lok valves with flat head screws, tighten all six screws until they just touch the plate before fully tightening any one screw. Tighten them in a criss-cross pattern. There should be a small gap between the plate and the valve body.

4. Install the handle O-ring (6), style 7600 handle spacer (14), and stop plate (4) as required.
 5. Position the handle in the proper position, apply a small amount of Locktite 222 or equivalent to the handle bolt (1) and install the bolt with the handle washer (2).
- Immediately test the operation of the handle. If it appears to be hard to turn, loosen the handle bolt approximately 1/4 turn.

REASSEMBLY—BALL AND SEATS

1. Install the new O-ring (15) on the threaded trunnion (16).
2. Use a 10" or larger flat file to clean up the flat surface of the adapters and mating surfaces of the valve body. Remove any paint, corrosion or raised lip around the bolt holes.

Caution: Always file diagonally and keep the file touching both sides of the valve body. The surfaces must remain flat.

3. Rotate the handle so that the flats on the sides of the ball trunnion (10) are parallel to the waterway.
4. Install the new ball (19) over the ball trunnion and hold it in position.
5. Install the threaded trunnion so that it fits into the hole in the ball. Tighten the trunnion.
6. Place the new seats into the recesses on either side of the valve body (21).
7. Swing the valve body back into line or install the assembly. Loosely install the adapter bolts.
8. Turn the ball to the closed position.

Caution: The ball must be in the closed position before the adapter bolts are tightened.

9. Tighten the adapter bolts evenly in an X pattern to the following torques:

7610/7810	1"	100 to 120 in.-lbs.	7625/7825	2 1/2"	25 to 30 ft.-lbs.
7615/7815	1 1/2"	215 to 240 in.-lbs.	7630/7830	3"	38 to 40 ft.-lbs.
7620/7820	2"	25 to 30 ft.-lbs.	7635/7835	3 1/2"	38 to 40 ft.-lbs.
			7840	4"	60 to 70 ft.-lbs.

DO NOT OVERTIGHTEN.

10. Operate the valve and test for leakage.

MAINTENANCE INSTRUCTIONS

Do not lubricate the ball or seats. Lubricants can collect dirt and grit which may cause excessive wear. Occasionally, flow water through all valves to clear dirt and debris.

OPERATING INSTRUCTIONS

Always open and close valves slowly.

Do not exceed 500 psi with 1 1/2", 2", 2 1/2", 3", 3 1/2" or 4" valves.

Do not exceed 1000 psi with 1" valves.

With SZ handles, always make sure that the handle has been tightened whenever the valve handle is released.