

- NOTES:
- GREASE ALL O-RINGS AND MATING SURFACES AT ASSEMBLY WITH PARKER O-LUBE
 - 1 USE PERMABOND #113 OR LOCTITE #222
 - 2 USE PERMABOND #HH-120 OR LOCTITE #277 REMOVE EXCESS MATERIAL AFTER CURING
 - 3 STAMP LETTER "T" AFTER CALIBRATION
 - 4 USE LOW TEMP LUBRIPLATE (PT.17235) AT ASSEMBLY
 - 5 CLEAN AND PRIMER BEFORE USING LOCTITE OR PERMABOND
 - 6 TORQUE TO 35-45 IN LBS
 - 7 USE PERMABOND #113 OR LOCTITE #222 ON SET SCREW AFTER CALIBRATION
 - 8 CENTER A BALL IN LOADING HOLE. SCREW IN SET SCREW UNTIL IT MAKES CONTACT WITH THE BALL. BACK OUT SET SCREW "SLIGHTLY" UNTIL SPINDLE MOVES FREELY.
 - 9 DIMPLE AT ASSEMBLY
 - 10 THOROUGHLY CLEAN THREADS OF PLUG AND MATING PART AND APPLY LOCTITE 425.

PHONE: 800.228.1161 | www.akronbrass.com

WARRANTY AND DISCLAIMER*: We warrant Akron Brass products for a period of five (5) years* after purchase against defects in materials or workmanship. Akron Brass will repair or replace product which fails to satisfy this warranty. Repair or replacement shall be at the discretion of Akron Brass. Products must be promptly returned to Akron Brass for warranty service. We will not be responsible for: wear and tear; any improper installation, use, maintenance or storage; negligence of the owner or user; repair or modification after delivery; failure to follow our instructions or recommendations; or anything else beyond our control. WE MAKE NO WARRANTIES, EXPRESS OR IMPLIED, OTHER THAN THOSE INCLUDED IN THIS WARRANTY STATEMENT, AND WE DISCLAIM ANY IMPLIED WARRANTY OF MERCHANTABILITY OR FITNESS FOR ANY PARTICULAR PURPOSE. Further, we will not be responsible for any consequential, incidental or indirect damages (including, but not limited to, any loss of profits) from any cause whatsoever. No person has authority to change this warranty. *Unless otherwise provided herein. Akron Brass industrial electronic components & the Severe-Duty Monitor have a one (1) year warranty. Select Akron Brass handline nozzles and valves carry a ten (10) year warranty. Scene Star Lights carry a (6) year warranty. Weldon products have a two (2) year warranty from date of manufacture (excluding consumable components). Select Weldon LED products carry a five (5) year warranty. Honda products have the manufacturers' warranty and Akron Brass disclaims any warranty in respect of those products.

Parts List Sheet:
 126420
 D48313



TECHNICAL SERVICE PARTS
 STYLE 5178
 PRODUCT 12/24V AKROMATIC 2000

IF AN ITEM IS NOTED AS "NOT FIELD REPAIRABLE", OR YOU WISH TO RETURN AN ITEM TO AKRON BRASS FOR SERVICE PLEASE GO ONLINE TO, ONLINEREPAIR.AKRONBRASS.COM

Chg.	Date
04	09-22
05	06-23

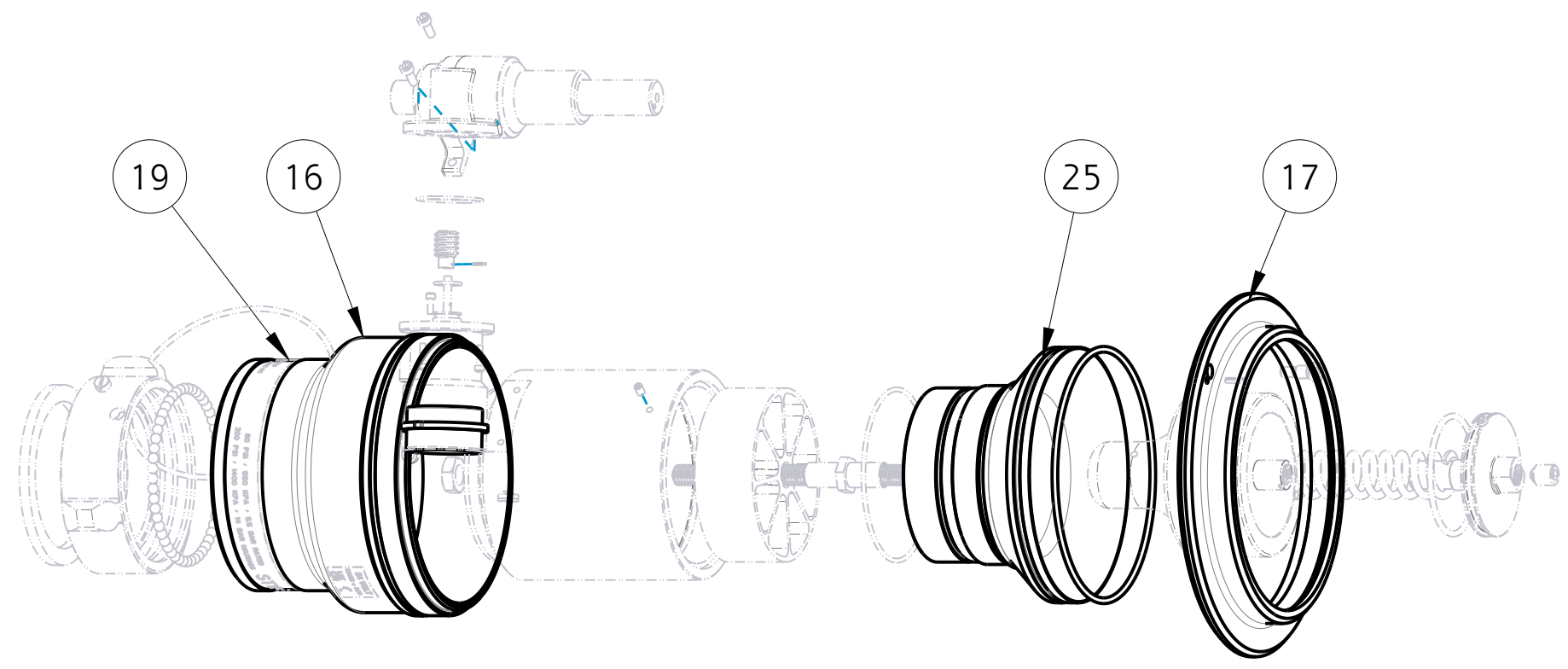

Find	Description	Item	QTY
16	*** PATTERN SLEEVE	119989	1
17	*** ACTUATOR ATTACHMENT RING	119990	1
19	*** BAND ID MADE IN U.S.A. 1500G/5700L 5178	803205	1
19	*** BAND ID MADE IN U.S.A. 2000G/7600L 5178	703640	1
25	*** THROAT	118248	1

*** OBSOLETE ACTUATOR ATTACHMENT RING

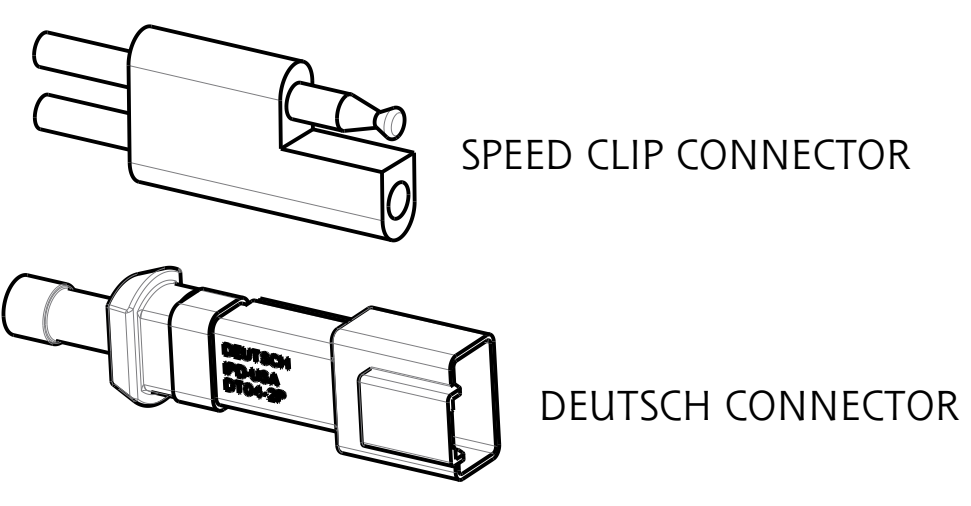

Find	Description	Item	QTY
1	BAFFLE S/A 1500 GPM	51700005	1
	BAFFLE S/A 2000 GPM	51700006	1
11	NOZZLE BODY	119988	1
12	O-RING 2-257	757527	1
13	SCREW 5/16 X 3/8-1/4-20	767131	1
16	PATTERN SLEEVE	126416	1
17	PIVOT BLOCK	126418	1
19	BAND ID 1500G/5700L 5178	803467	1
19	BAND ID 2000G/7600L 5178	803468	1
20	SWIVEL 3.5"	128438	1
21	* BRASS BALL Ø 1/4"	703017	53
22	RUBBER GASKET	714023	1
23	SWIVEL PLUG	742023	1
24	STREAM SHAPER	118247	1
25	THROAT	126415	1
26	O-RING 2-155	757372	1
27	SCREW 10-24 X 5/16	765040	1
29	TEFLON BEARING	703556	1
102	PATTERN ACTUATOR OVERRIDE	51782008	1
103	12V MOTOR ASSEMBLY WITH SPEED CLIP	50770028	1
	24V MOTOR ASSEMBLY WITH SPEED CLIP	50770029	1
	12V MOTOR ASSEMBLY WITH DEUTSCH CONNECTOR	33560006	1
	24V MOTOR ASSEMBLY WITH DEUTSCH CONNECTOR	33560008	1
104	** O-RING 2-015	757525	1
105	** WORM GEAR	785021	1
107	** ROLL PIN 1/16 X 3/8	744341	1
109	** O-RING 2-029	757247	1
110	ROLL PIN 1/8 X 1/2	744288	1
111	** SCREW 6-32 X 1/2	765150	4
124	SCREW 10-24 X 1/2	763038	2
125	SET SCREW 1/4-20 X 1/4	765372	2
150	TAG CE/UKCA (OPTIONAL)	773605	1
151	LABEL NFPA 1964	729181	1

* KIT OF 50 BALLS: 109041
 ** ITEMS INCLUDED IN MOTOR ASSEMBLY ITEM 103

PHONE: 800.228.1161 | www.akronbrass.com

Parts List Sheet:
 126420

WARRANTY AND DISCLAIMER*: We warrant Akron Brass products for a period of five (5) years* after purchase against defects in materials or workmanship. Akron Brass will repair or replace product which fails to satisfy this warranty. Repair or replacement shall be at the discretion of Akron Brass. Products must be promptly returned to Akron Brass for warranty service. We will not be responsible for: wear and tear; any improper installation, use, maintenance or storage; negligence of the owner or user; repair or modification after delivery; failure to follow our instructions or recommendations; or anything else beyond our control. WE MAKE NO WARRANTIES, EXPRESS OR IMPLIED, OTHER THAN THOSE INCLUDED IN THIS WARRANTY STATEMENT, AND WE DISCLAIM ANY IMPLIED WARRANTY OF MERCHANTABILITY OR FITNESS FOR ANY PARTICULAR PURPOSE. Further, we will not be responsible for any consequential, incidental or indirect damages (including, but not limited to, any loss of profits) from any cause whatsoever. No person has authority to change this warranty. *Unless otherwise provided herein. Akron Brass industrial electronic components & the Severe-Duty Monitor have a one (1) year warranty. Select Akron Brass handline nozzles and valves carry a ten (10) year warranty. Scene Star Lights carry a (6) year warranty. Weldon products have a two (2) year warranty from date of manufacture (excluding consumable components). Select Weldon LED products carry a five (5) year warranty. Honda products have the manufacturers' warranty and Akron Brass disclaims any warranty in respect of those products.
 © 2016 Akron Brass Company. All rights reserved. No portion of this can be reproduced without the express written consent of the Akron Brass Company.