



## STYLE 3580 RENEGADE™ INSTALLATION, OPERATING, AND MAINTENANCE INSTRUCTIONS

The following is intended to provide the basic instructions for installation, operation and maintenance of the Renegade electric monitor, and to assist in attaining the best possible performance from the unit. Read and understand these operating instructions before use.

### TOOLS REQUIRED

- Utility Knife
- Medium Phillips screwdriver
- Small Phillips screwdriver
- Electrician's pliers (multipurpose, stripping and crimping)
- Medium flat screwdriver
- Small flat screwdriver
- 1/2 inch hex head wrench

### PRODUCT RATINGS

Maximum Motor Current Draw:

- |                  |   |
|------------------|---|
| 12 volt versions | 4 amps each for elevation and rotation motors |
|                  | 4 amps for nozzle pattern motor               |

Normal Operating Current: (Depending on operating conditions—pressure, flow, etc.)

- |                  |   |
|------------------|---|
| 12 volt versions | 2 to 3 amps each for elevation and rotation |
|                  | 2 to 3 amps for nozzle pattern motor        |

Minimum Voltage: **(Truck engine must be operating for proper voltage requirement.)**

All 12 volt motors: 11.5 volts while operating

Mass: 150 lbs. (68 kg)

Maximum Flow: 5000 gpm (19000 lpm)

Maximum Pressure: 150 psi (14 bar)

### PRODUCT WARNINGS

- ⚠ WARNING:** Charge the unit slowly. Rapid charging may cause a pressure surge that has the potential to cause an injury, or damage the monitor.
- ⚠ WARNING:** DO NOT stow or deploy the Renegade monitor while flowing. Pressing the stow or deploy buttons causes the nozzle to move automatically and the water stream may cause damage to equipment or injury to personnel.
- ⚠ WARNING:** Aim the unit in a safe direction before pumping water through it. (i.e. Away from power lines)
- ⚠ WARNING:** Although the circuit board includes a water-resistant coating, it is important to keep water out of the control box and logic box. Prolonged exposure to water will cause damage.
- ⚠ WARNING:** When the cover of the control box or logic box is removed, check that the O-ring under the cover is intact and free of dirt and debris.
- ⚠ WARNING:** The Renegade monitor uses current limiting for both the monitor and nozzle. Use only appropriate Akron Brass Company nozzles.
- ⚠ WARNING:** Do not use the electric controls when the override cranks are being used or are in position for use.
- ⚠ WARNING:** Make the connection of the vehicle and auxiliary battery the final step.
- ⚠ WARNING:** Replace the identification tags if they should become worn or damaged.
- ⚠ WARNING:** DO NOT exceed the maximum pressure or flow ratings of the monitor. Exceeding these ratings may lead to an injury or may cause damage to the monitor.

- ⚠ **WARNING:** DO NOT install shutoffs on the outlet of the monitor. Shutoffs increase the potential for pressure surges due to water hammer, which have the potential to cause an injury or damage to the monitor.
- ⚠ **WARNING:** The Renegade monitor, nozzle, logic box, control box, tether controller, and field adjustable stops are made for optimal performance. Do not alter in any manner.
- ⚠ **WARNING:** The Renegade monitor was designed for use with the Akron nozzle. Use of any other nozzle could affect the speed or operation of the unit and should be tested before being put into service.
- ⚠ **WARNING:** The Renegade monitor contains moving parts. Keep hand, finger and objects away from pinch points.
- ⚠ **WARNING:** Disconnect power and disable flow before maintenance.
- ⚠ **WARNING:** Keep all personnel out of the Danger Zone, in front of the outlet of the monitor when the water source is attached. Dangerous flow velocities can cause serious injury.
- ⚠ **WARNING:** Not designed for explosive environments.



## GENERAL INSTRUCTIONS

- Review the instructions, wiring diagram, component layout and rotational stops diagram before installing this unit. This unit operates on 12 or 24 volt DC. All electrical current flows through the wires. The monitor does not act as a ground. The wires from the control boxes can be cut to the length for the application. Do not extend the wires from the logic box to the monitor.
- The optional auxiliary battery is used to ensure that the proper voltage and current are maintained at the logic box when using a smaller gauge wire (12 Awg) for the power leads (vehicle battery). If the optional auxiliary battery is used, do not extend the auxiliary battery wires. This will ensure that the proper voltage and current are maintained at the monitor for it to operate properly. The optional battery is automatically recharged by the truck electrical system through the positive (auxiliary battery) and ground connections on the circuit board. The vehicle battery connections must have power turned on whenever the truck is running so that the battery can be recharged properly. If possible, connect the positive (vehicle battery) wire directly to the main vehicle battery or main master switch. A diode in the logic box will prevent the optional auxiliary battery from feeding current back into the main truck system.
- Not recommended for use in salt water applications.
- For firefighting by trained firefighters only.
- For use with water or standard fire fighting foams only. After use with foam, flush with fresh water.
- Do not use the Renegade nozzle as a forcible entry tool.
- Drain the Renegade monitor and nozzle after use to prevent “freeze damage”.
- Ensure that the thread in the nozzle swivel matches the thread on the Renegade outlet. Do not overtighten the nozzle onto the Renegade.

## MECHANICAL MONITOR ATTACHMENT

The Monitor is to be mounted on the waterway with eight  $\frac{3}{4}$  inch bolts and nuts of grade five minimum and suitable washers with a minimum of six threads engagement. The bolts must be tightened in a criss cross pattern progressively increasing tightening torque to a maximum of 100 foot pound dry. The front of the monitor will have a dimple on the inlet flange (Figure 4).

NOTE: Not recommended to mount on a raised flange or have a butterfly valve between the flanges. This may cause damage to the monitor's flange when tightening the bolts.

## MECHANICAL ATTACHMENT OF CONTROLLER AND LOGIC BOX

### A. CONTROLLER AND TETHER CONNECTOR ATTACHMENT

Pump panel cut out and mounting hole dimensions are given in Figure 2 & 3. The controller and tether connector should be installed in the pump panel prior to electrical connection to the logic box.

### B. LOGIC BOX ATTACHMENT

The Renegade logic box must be mounted close enough to the monitor to allow the 8 ft. monitor wiring harness sufficient slack to allow the monitor to travel through its full range. The logic box overall dimensions and mounting hole dimensions are given in Figure 5.

⚠ **WARNING:** Do not extend the monitor wiring harness.

## ELECTRICAL INSTALLATION INSTRUCTIONS

### A. CONTROLLER, JOYSTICK OR TETHER CONNECTOR ELECTRICAL ATTACHMENT

These instructions are for attaching the controller, joystick or the tether connector to the logic box. The controller, joystick and tether connector are supplied with 8 ft. of cable.

**STEP 1** If the controllers include an attached cable skip to STEP 6.

**STEP 2** Determine the length of #20-7 cable needed, add 10 inches, then cut. For example, if a five foot length of cable is needed, add 10 inches and cut the cable 5 foot 10 inches long.

- STEP 3** Remove the cable grip nut and washer from the control box and put it on the cable with the threads facing the box. On the same end of the cable remove 4 inches of the outer casing of the cable and strip back  $\frac{3}{8}$  inch from each of the 7 wires.
- STEP 4** Take the 7 ring terminals from the plastic bag and crimp them on the 7 wires. Remove the four control box cover screws and set the control box cover aside. Thread the 7 wires through the cable grip attached to the control box and attach them to the proper terminals. Tighten the cable grip nut and washer on the cable to the cable grip on the control box to secure the cable. Reattach control box cover and secure with the four screws.
- STEP 5** Remove the cable grip nut from the plastic bag and put it on the other end of the cable with the threads facing out. Remove 6 inches of the outer cover and strip back  $\frac{3}{8}$  inch from each of the 7 wires.
- STEP 6** Remove the 6 logic box cover screws and set the logic box cover aside. Thread the 7 wires through the upper or lower control hole in the logic box (see component layout, Figure 5). Thread the cable grip washer and cable grip nut with the threads facing the box on the cable. Pull enough cable through the cable grip to ensure a good fit. Tighten the cable grip nut and attach the individual wires to the proper terminals (see wiring diagram Figure 6). Reattach the logic box cover and secure with the 6 screws.
- NOTE:** The lower control and upper control wires must be attached to the correct terminals for the lower control to override the upper control. The one attached to the Master terminal will have the overriding capabilities. Adjust the DIP switch settings as needed. (Refer to the description below.)

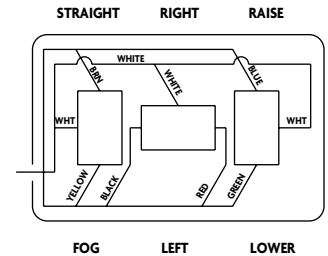

### B. DIP SWITCH SETTINGS

The DIP switches are located in the logic box on the circuit board.

The switches are factory set at:

	1	2	3	4	5	6	7	8
On								
Off	•	•	•	•	•	•	•	•

- Switch 1 - Water ON only if deployed  
ON - Can only open valve when monitor is deployed.  
OFF - Can open valve in stowed position.
- Switch 2 - Return to stream during stow
- Switch 3 - Soft start disable
- Switch 4 - Operates the monitor when mounted upside down.  
ON - Inverted Mount  
OFF - Upright Mount
- Switch 5 - Allows the ability to reduce the Elevation Speed  
ON - Reduces the Elevation speed 60%
- Switch 6 - Allows the ability to reduce the Elevation Speed  
ON - Reduces the Elevation speed 50%
- If both 5 and 6 are ON: will reduce the speed 40%**
- Switch 7 - Allows the ability to reduce the Rotation Speed  
ON - Reduces the Rotation speed 60%
- Switch 8 - Allows the ability to reduce the Rotation Speed  
ON - Reduces the Rotation speed 50%
- If both 7 and 8 are ON: will reduce the speed 40%**

### C. MONITOR WIRING HARNESS ATTACHMENT

These instructions are to attach the monitor wiring harness to the logic box.

- STEP 7** Remove the cable grip nut from the logic box for the wiring harness cable. **DO NOT REMOVE THE CABLE GRIP.** Put the cable grip nut on the wiring harness cable with the threads facing out. Put the cable through the correct logic box cable grip (see component layout, Figure 5) so the cable grip nut will grab the outer cover of the cable. Tighten the cable grip nut and attach the individual wires to the proper terminals (see wiring schematic Figure 6).

## D. BATTERY ATTACHMENT

The battery connections should be the last connection made.

**STEP 8** AUXILIARY BATTERY - Remove the logic box cable grip nut for the auxiliary battery and place it on the battery (#16-3) cable with the threads facing out. Thread the cable through the cable grip nut until the cable grip will grab the cable. Tighten the cable grip and attach the individual wires to the proper terminals (see wiring schematic Figure 6).

NOTE: Auxiliary Battery is not intended to operate the monitor.

**STEP 9** VEHICLE BATTERY - Remove the logic box cable grip nut for the vehicle battery and place it on the battery cable (#10-2 or #12-2 depending on length) with the threads facing out. Thread the cable through the cable grip until the cable grip nut will grab the cable. Tighten the cable grip nut and attach the individual wires to the proper terminals (see wiring schematic Figure 6). Reattach the logic box cover and secure with the 6 screws.

NOTE: To supply enough current to operate the monitor properly, adequate wire size is critical.

## OPERATING INSTRUCTIONS

### A. CONTROLLER OPERATION

The controller is used to control the monitor and nozzle.

1. To change the horizontal monitor position toward the right or left:  
Press the proper toggle switch toward "RIGHT" or "LEFT" respectively, as labeled on the controller, until the desired position is reached.
2. To change the vertical monitor nozzle position upward or downward:  
Press the proper toggle switch toward "RAISE" or "LOWER" respectively, as labeled on the controller, until the desired position is reached.
3. To change the nozzle pattern toward the straight stream or fog position:  
Press the proper toggle switch toward "STRAIGHT" or "FOG" respectively, as labeled on the controller, until the desired nozzle position is reached.

THE LOWER CONTROL BOX FUNCTIONS WILL OVERRIDE THE UPPER CONTROL BOX FUNCTIONS IN COMPLIANCE WITH THE REQUIREMENTS OF THE NFPA STANDARD. NOTE: THE LOWER CONTROL AND UPPER CONTROL WIRES MUST BE ATTACHED TO THE CORRECT TERMINALS FOR THE LOWER CONTROL (MASTER) TO OVERRIDE THE UPPER CONTROL (SLAVE). NONE OF THE FUNCTIONS CAN BE CONTROLLED FROM THE UPPER CONTROL BOX WHEN ANY OF THE SWITCHES ON THE LOWER CONTROL BOX ARE ACTIVATED.

### B. MANUAL OVERRIDE CONTROLS

The manual override control is to be used only when the power to the monitor is off. To use the manual override, insert a 3/8" hex drive end into the hexagon shaped hole. Rotate the override crank in the desired direction to aim the monitor. See Figure 4 for locations of override.

### C. STOPS

The physical stop locations can be changed in the horizontal rotation to 340° rotation or to ±22.5° rotation from center. See Figure 4A for stop and plug locations for the appropriate rotation. The Renegade can also be taught new rotation and elevation limits and stow and deploy limits. See section D "Learn Mode".

### D. LEARN MODE

Rotation and Elevation Limits:

The soft limits are not set at the factory. To change the soft limits:

- Shut down Power to monitor.
- Hold down the SS switch and turn the power on. Release the SS switch.
- The LED will flash twice for the set-up mode of the Rotation and Elevation limits. To continue to the Stow and Deploy set-up mode press and release the SS switch. The LED will flash three times for the Stow and Deploy set-up mode.

Rotation Limits

- Move the monitor to the desired Left limit (release the switch)
- Hold down the Fog switch and press and release the Left switch and then release the Fog switch. This will set the Left limit.
- Move the monitor to the desired Right limit (release the switch)
- Hold down the Fog switch and press and release the Right switch and then release the Fog switch. This will set the Right limit.

Elevation Limits

- Move the monitor to the desired upper limit (release the switch)

- Hold down the Fog switch and press and release the Raise switch and then release the Fog switch. This will set the upper limit.
- Move the monitor to the desired lower limit (release the switch)
- Hold down the Fog switch and press and release the Lower switch and then release the Fog switch. This will set the lower limit.

Press and release the SS switch to exit the Rotation and Elevation set-up mode and enter the Stow and Deploy set-up mode.

Stow and Deploy:

- The LED will flash three items for the set-up mode for the Stow and Deploy.

Stow Position

- Move the monitor to the desired stow position.
- Hold down the Fog switch and press and release the Stow switch and then release the Fog switch.

This will set the Stow position.

- Deploy Position (if applicable)
- Move the monitor to the desired Deploy position.
- Hold down the Fog switch and press and release the Deploy switch and then release the Fog switch. This will set the Deploy position.

Press and release the SS switch to exit the Set-up mode.

## E. STATUS AND ERROR CODES

The LED on the operator station gives an indication of what mode you are in and a diagnostic indicator. The following are the list of Flashes and the corresponding indication:

- Fast Flash: The monitor is Stowing or Deploying
- Slow Flash: The monitor is Oscillating
- Constant On: The monitor is Deployed
- Constant Off: The monitor is Stowed
- Two Blinks: Learn mode for Rotation and Elevation
- Three Blinks: Learn mode for Stow and Deploy
- Four Blinks: Voltage on position feedback Potentiometer is too low (Oscillation, Stow, Deploy and the Elevation and Rotation limits will not operate)
- Five Blinks: Voltage on the position feedback Potentiometer is not changing (Oscillation, Stow, Deploy and the Elevation and Rotation will not operate)

## MAINTENANCE INSTRUCTIONS

Your Renegade monitor and nozzle should be inspected prior to and after each use to ensure it is in good operating condition. Periodically, an unanticipated incident occurs where the unit is misused in a manner that is inconsistent with standard operating practices. A partial list of potential misuses includes:

- Operating above the maximum rated pressure or flow.
- Prolonged exposure to temperatures above 130°F, or below -25°F.
- Operating in a corrosive environment.
- Having the Renegade nozzle hit a fixed object during operation or transportation.
- Any other misuse that might be unique to your specific environment.

Also, there are many “tell tale” signs that indicate repair is in order, such as:

- Controls that are either inoperable or difficult to operate.
- Poor discharge performance.
- Excessive wear.
- Water leaks.

If any of the above situations are encountered, the Renegade monitor should be taken out of service, repaired, and tested by a qualified technician before placing back in service.

**Figure 1**

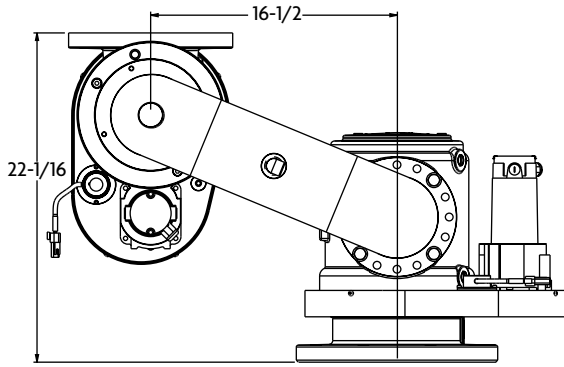

**22.5° Orientation**

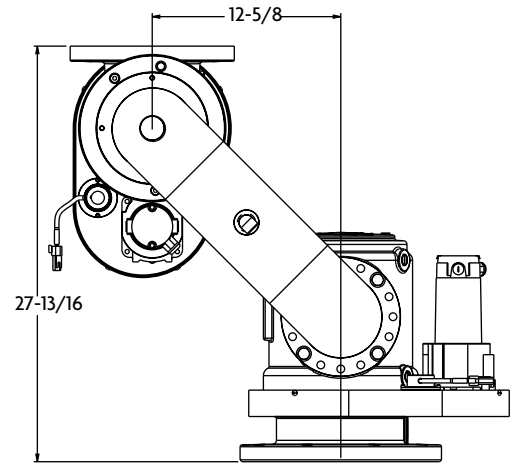

**45° Orientation**

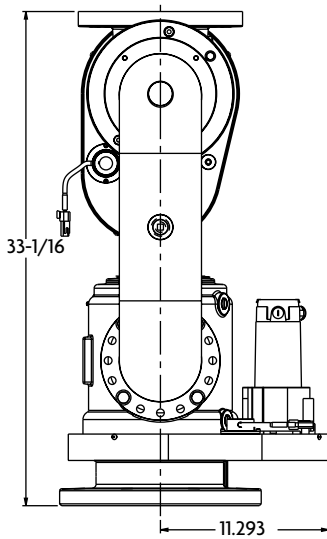

**90° Orientation**

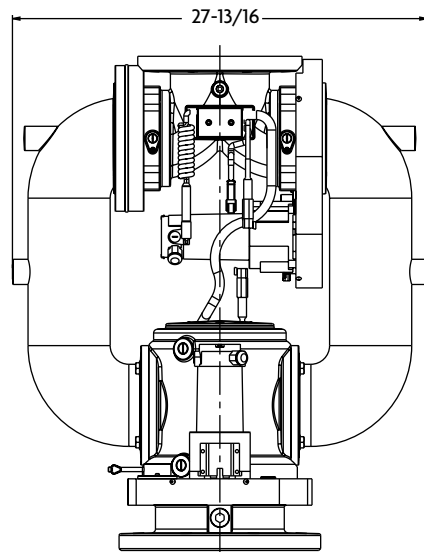
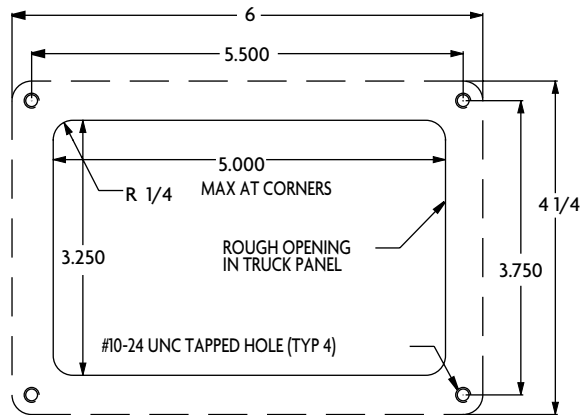
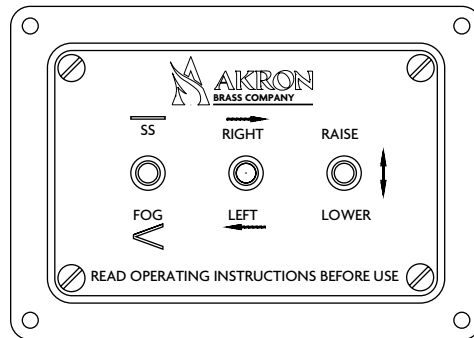
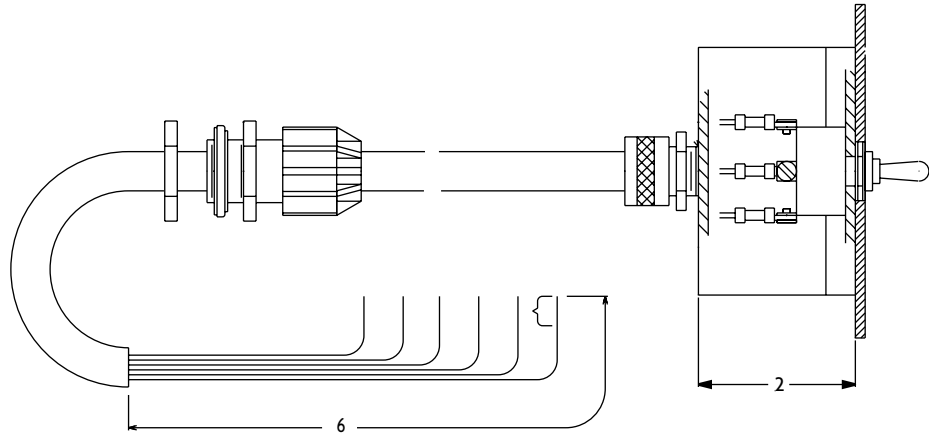

Figure 2

Panel Mount Controller



TRUCK PANEL CUT OUT DIMENSIONS

**Figure 3**

**Joystick**

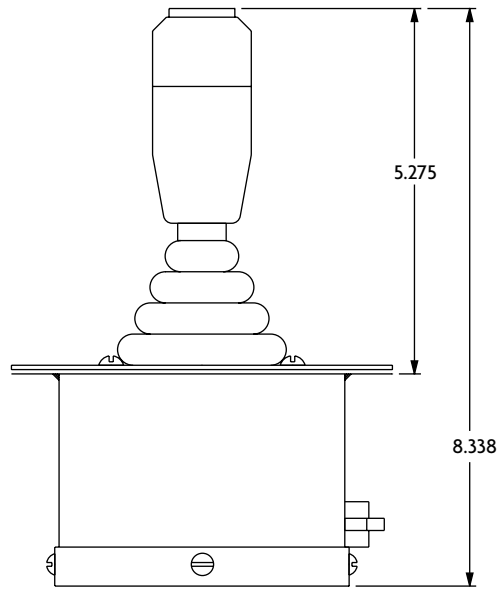
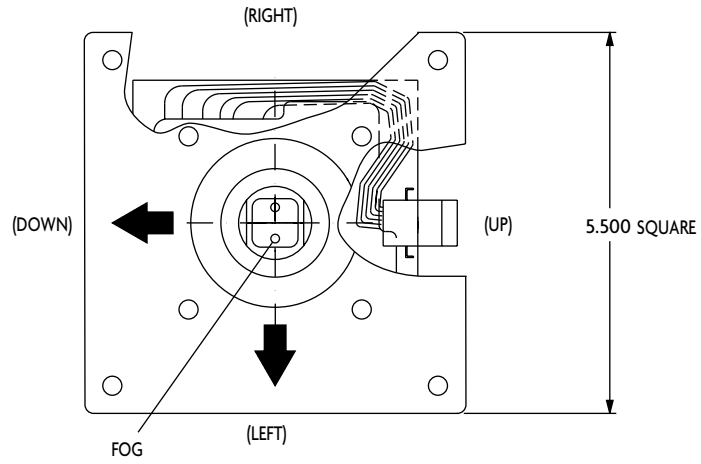

**Tether Connector**

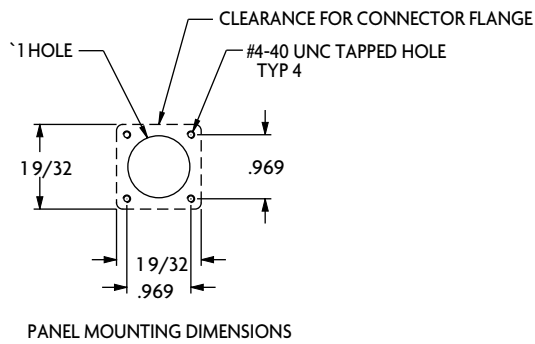
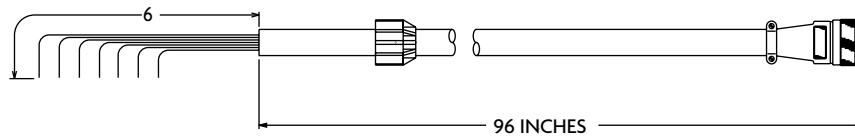



**Figure 4**

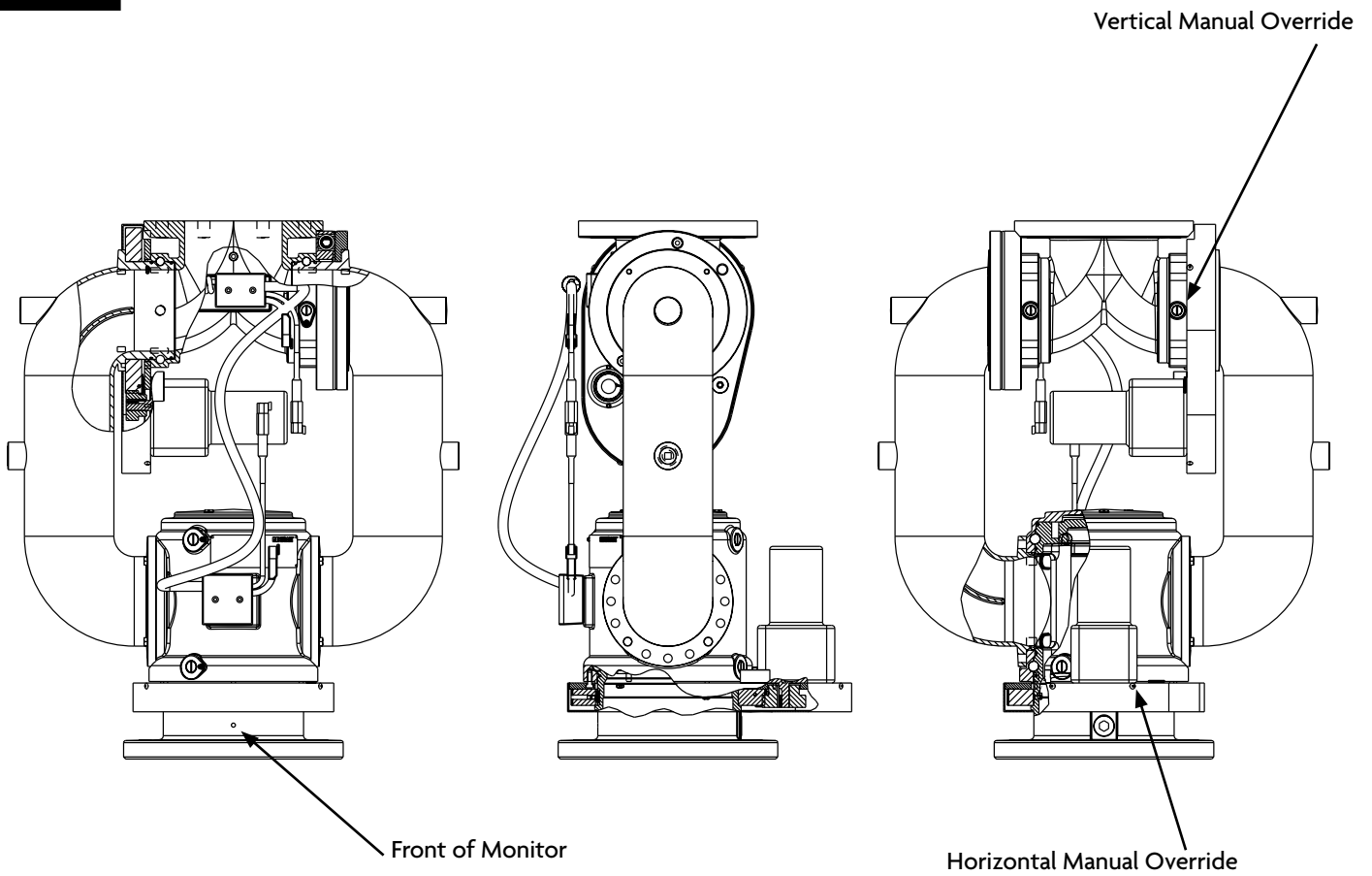

**Figure 4a**

**Horizontal Rotational Stops**

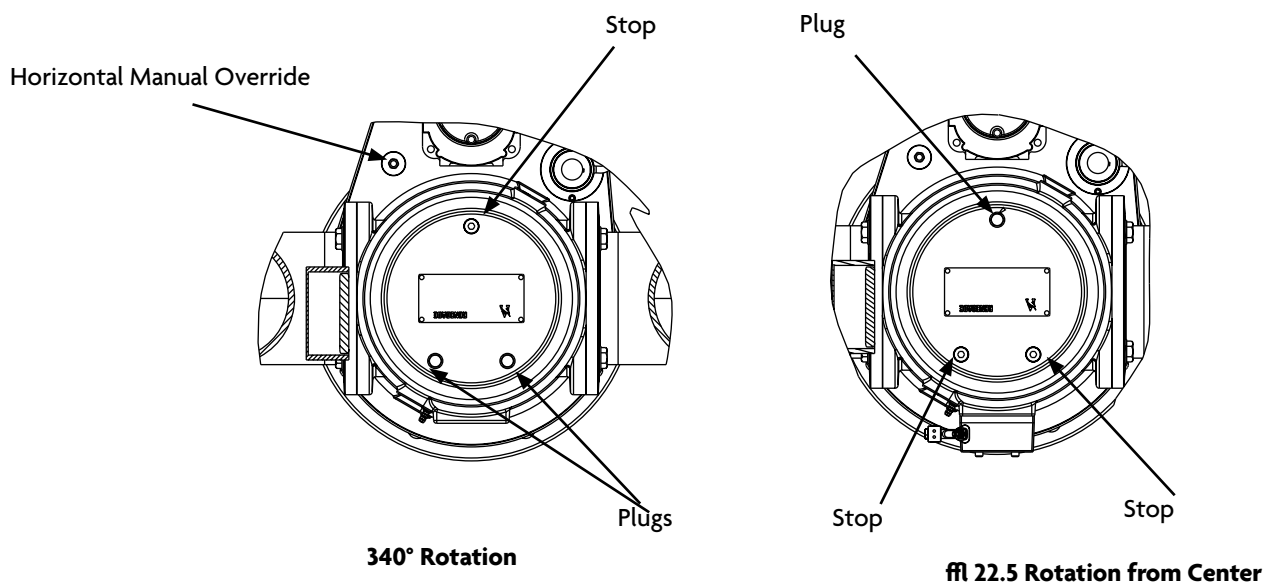
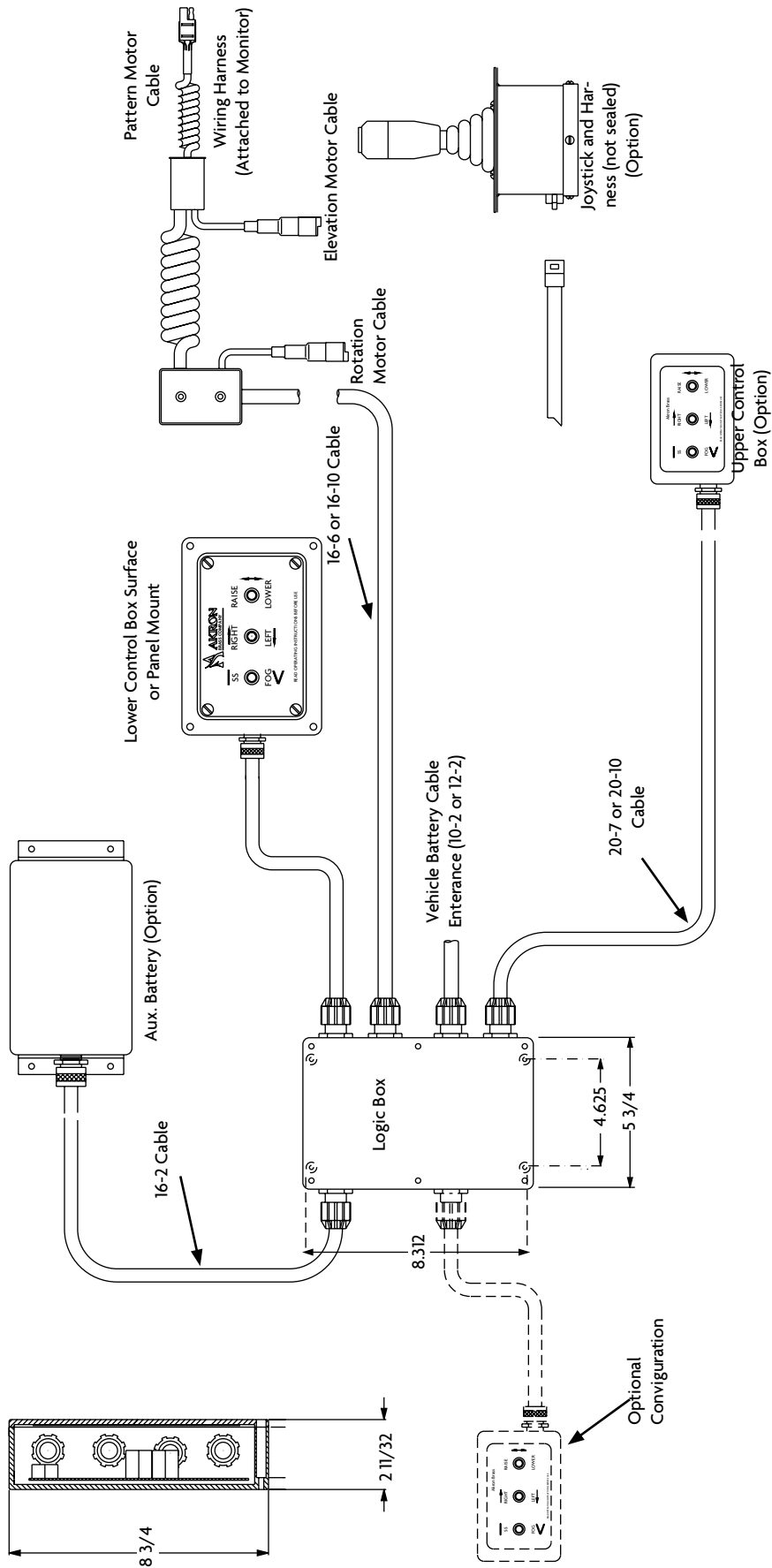

Figure 5

Electrical Component Layout



**Controller Symbols**

- Straight Stream
- < Fog
- ← Right
- Left
- ↑ Up
- ↓ Down

Figure 6

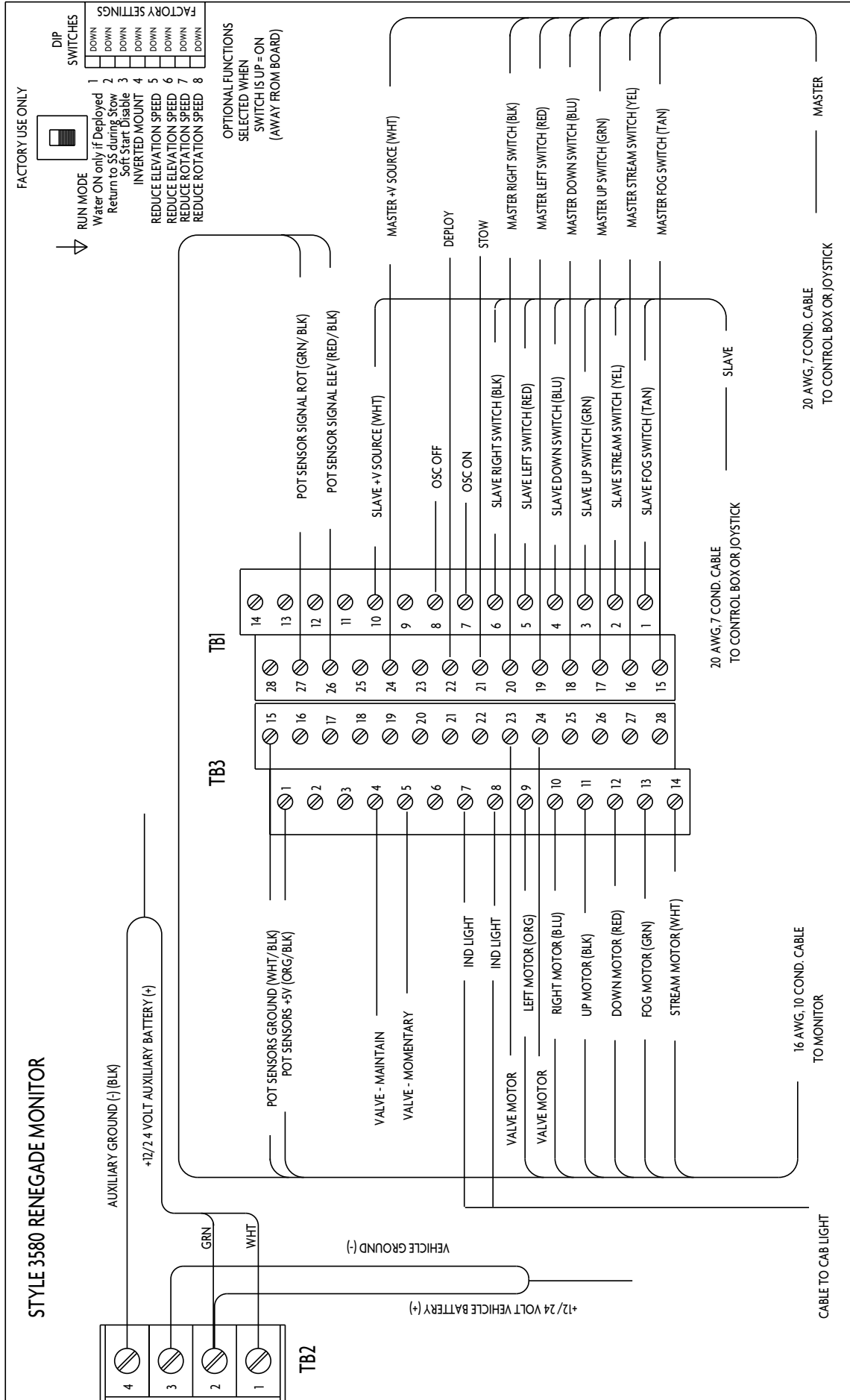



**Tested... Proven... Trusted.**

ISO 9001 REGISTERED COMPANY

PHONE: 330.264.5678 or 800.228.1161 | FAX: 330.264.2944 or 800.531.7335 | [akronbrass.com](http://akronbrass.com)

REVISED: 03/13

WARRANTY AND DISCLAIMER: We warrant Akron Brass products for a period of five (5) years after purchase against defects in materials or workmanship. Akron Brass will repair or replace product which fails to satisfy this warranty. Repair or replacement shall be at the discretion of Akron Brass. Products must be promptly returned to Akron Brass for warranty service.

We will not be responsible for: wear and tear; any improper installation, use, maintenance or storage; negligence of the owner or user; repair or modification after delivery; damage; failure to follow our instructions or recommendations; or anything else beyond our control. WE MAKE NO WARRANTIES, EXPRESS OR IMPLIED, OTHER THAN THOSE INCLUDED IN THIS WARRANTY STATEMENT, AND WE DISCLAIM ANY IMPLIED WARRANTY OF MERCHANTABILITY OR FITNESS FOR ANY PARTICULAR PURPOSE. Further, we will not be responsible for any consequential, incidental or indirect damages (including, but not limited to, any loss of profits) from any cause whatsoever. No person has authority to change this warranty.

© Akron Brass Company, 2011 All rights reserved. No portion of this can be reproduced without the express written consent of Akron Brass Company.