

ELECTRICAL JUNCTION BOX ASSY.

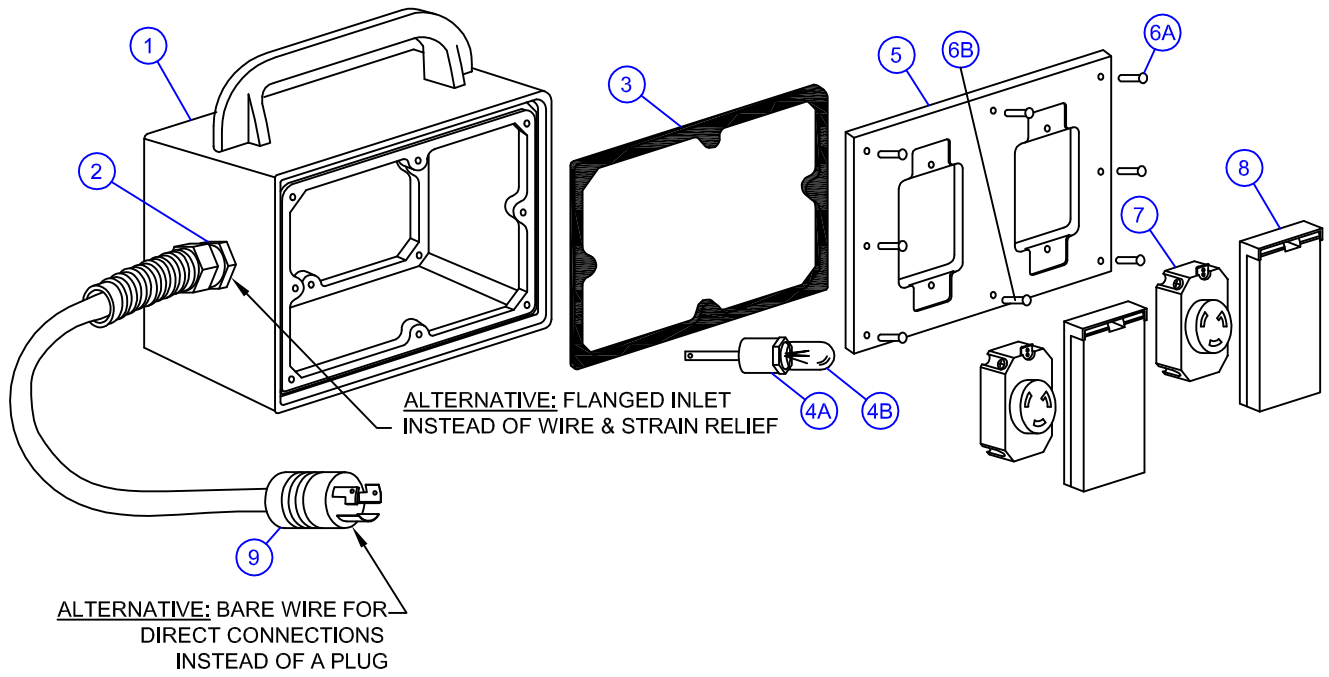

PARTS LIST FOR ENTIRE JUNCTION BOX			
ITEM NO.	PART NO.	DESCRIPTION	QTY.
1	117-BX-M1	JUNCT. BOX HOUSING	1
2	133-SR	3/4" FLEX STRAIN RELIEF	1
3	117-FG	FACEPLATE GASKET	2
4A	114-BS	LAMP SOCKET	1
4B	116-WB	INTERNAL 25 WATT LAMP	1
5	117-FP	POLYPROP. FACEPLATE	2
6A	423-JB	FACEPLATE SCREW	16
6B	424-JB	FASTENER ASSEMBLY *	1
7	22(X)-R	OUTLET RECEPTACLE **	4
8	25(X)-CV	OUTLET SNAP COVER **	4
9	20(X)-PG	PLUG **	1

FOR PLUGS AND CONNECTORS NEMA CONFIGURATIONS SEE THE EXTENDA-LITE JUNCTION BOX ORDER FORM.

* USED IN ONE HOLE TO ATTACH INTERNAL LIGHT SOCKET TO BOX. INCLUDES 8-32 x 1 NUT (632-NT) AND MACHINE SCREW (424-JB)

** IN PLACE OF (X), SPECIFY THIRD NUMBER OF PLUG, COVER, OR RECEPTACLE DESIRED.

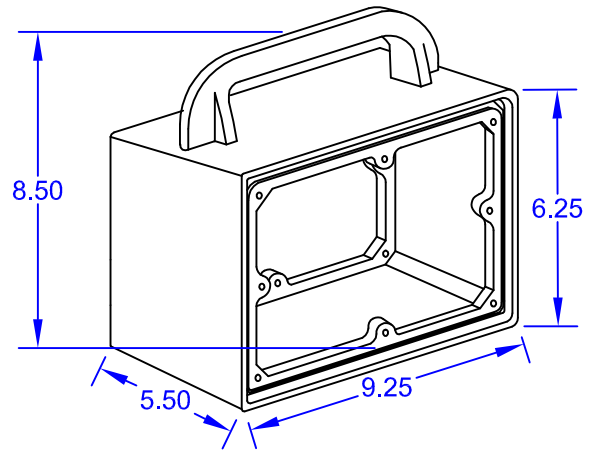

ISO-9001 CERTIFIED

Akron Brass Company
 A Premier Farnell Company

501 N. Cummings Lane, Washington, IL 61571
 Phone: (309)444-4440 Fax: (309)444-8766