

THIS DRAWING AND ALL INFORMATION CONTAINED HEREIN IS THE PROPERTY OF WELDON TECHNOLOGIES, INC. AND MAY NOT BE COPIED, REPRODUCED, OR DEVULGED TO UNAUTHORIZED PERSONS WITHOUT THE EXPRESS WRITTEN CONSENT OF WELDON TECHNOLOGIES, INC. AS IT IS BEING PROVIDED SOLELY FOR THE CONVENIENCE OF THE USER AND SHALL BE RETURNED TO WELDON TECHNOLOGIES, INC. UPON REQUEST.

REVISIONS					
REV.	ECN	DESCRIPTION	DATE	BY	APVD
A	R0822	DOCUMENTATION RELEASE	5/9/08	TB	ST

LENS SCREW
TIGHTENING TORQUE
8-12 in/lbs

CLEARANCE FOR
#10 SCREW (MAX.)
(4 PLCS.)
INSTALLATION TORQUE
18 in/lbs (MAX.)

Ø 6.25
BOLT CIRCLE

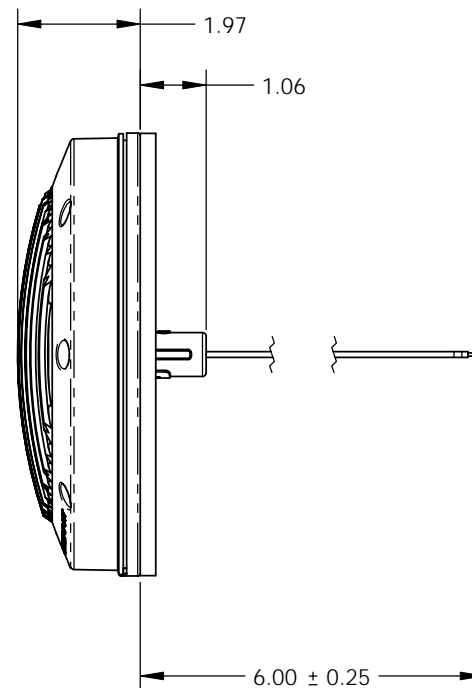
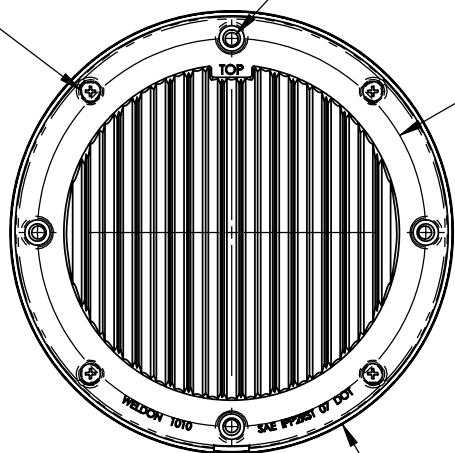

Service Part Number	Description	Qty.
1003-1000-30	Lens, Acrylic, Clear	1
1014-0000-00	Gasket, Lens	1
1015-0000-00	Gasket, Mounting	1
9018-0019-00	Bulb, Miniature, #1141, 21cp	1
9028-0006-00	Screw, Lens, 8-32 x 7/16 PPHMS, TT	4

1013-1100-30

UNLESS OTHERWISE SPECIFIED
DIMENSIONS ARE IN INCHES
TOLERANCES ARE:
X.XXX - ±0.005
X.XX - ±0.020
X.X - ±0.050
ANGLES - ±0.5°

APPROVALS		DATE
DRAWN	TB	5/1/08
CHECKED	ST	5/3/08
QUAL ENG		
MFG ENG		

WELDON TECHNOLOGIES, INC.

CUSTOMER DRAWING
7" ROUND
D.O.T. LAMP

MATERIAL	
FINISH	
DO NOT SCALE DRAWING	

PROJ. NO.	
-----------	--

SIZE	PART NO.	REV.
B	C1013-1100-00	A
SCALE:	1:1	

WELDON COMPUTER GRAPHICS | SHEET 1 OF 1