

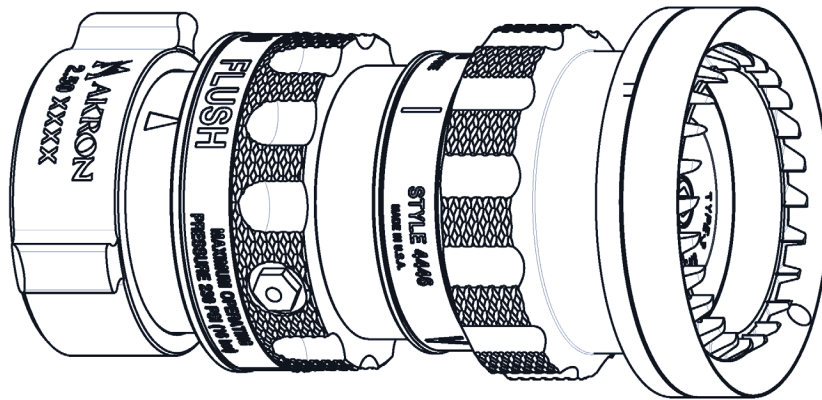

STYLE 4446 SELECTABLE FLOW NOZZLE INSTALLATION, OPERATING, AND MAINTENANCE INSTRUCTIONS

The following is intended to provide the basic instructions for installation, operation, and maintenance. Read and understand these operating instructions before use.



Read and follow the operating instructions before use.

For firefighting use only.

Product Ratings

Mechanical Specifications:

Parameter	US Measure	Metric Measure
Flow Rate	250/375/500 GPM	950/1400/1900 LPM
Pressure	80/87/100PSI*	5.5/6/7 Bar*
Mass	6.2 Lbs	2.8 kg

*Factory preset as required

PHONE: 330.264.5678 or 800.228.1161 | FAX: 330.264.2944 or 800.531.7335

www.akronbrass.com



STYLE 4446 SELECTABLE FLOW NOZZLE INSTALLATION, OPERATING, AND MAINTENANCE INSTRUCTIONS

⚠ DANGER

- Indicates a hazardous situation which, if not avoided, WILL result in death or serious injury.

⚠ WARNING

- Indicates a hazardous situation which, if not avoided, COULD result in death or serious injury.

⚠ CAUTION

- Indicates a potentially hazardous situation which, if not avoided, may result in minor or moderate injury.

NOTICE

- Addresses practices not related to personal injury.

⚠ DANGER

- Not for use on electrical fires.

⚠ WARNING

- Charge all lines slowly to facilitate a controlled water pressure build-up during start-up. Open and close slowly. Rapid opening will produce a sudden thrust. Rapid opening and closing can cause water hammer. Have enough firefighters on the line to safely control the reaction force created by the stream.

⚠ WARNING

- At pressures below that indicated on the label, the nozzle will have reduced flow and reach. Be sure you have enough flow and pressure for the situation (See IFSTA and NFPA manuals for guidelines).

⚠ WARNING

- The amount of flow to a nozzle is controlled at the pump, not at the nozzle. Therefore, unanticipated increases and decreases in flow can occur without the knowledge of the nozzle operator. This can cause serious consequences (i.e. too little flow to extinguish the fire, or increased reaction force which the nozzle operator may be unable to handle).

⚠ WARNING

- Do not use the nozzle in portable hose holders.

⚠ WARNING

- Ensure the nozzle is aimed in a direction that is safe.

⚠ WARNING

- Ensure the thread on the nozzle swivel is matched to the thread on the monitor connection.

⚠ WARNING

- Do not use the nozzle as a shut-off when testing hose.

⚠ WARNING

- When operating at lower pressures the hose can kink more easily. A kink in the hose chokes off the flow, which may result in inadequate flow for the situation.

⚠ CAUTION

- Your nozzle should be inspected prior to and after each use, to ensure it is in good operating condition. Periodically, an unanticipated incident may occur where the nozzle is used in a manner that is inconsistent with standard operating practices and those listed in IFSTA. A partial list of potential misuses follows:
 - Operating above maximum rated pressure and flow.
 - Not draining, and allowing water to freeze inside the nozzle.
 - Dropping the nozzle from a height where damage is incurred.
 - Prolonged exposure to temperatures above +130 degrees F, or below -25 degrees F.
 - Operating in a corrosive environment.
 - Other misuse that might be unique to your specific fire fighting environment.
- There are many “tell tale” signs that indicate nozzle repair is in order, such as:
 - Controls that are inoperable or difficult to operate.
 - Excessive wear.
 - Poor discharge performance.
 - Water leaks.

If any of the above situations are encountered, the nozzle should be taken out of service and repaired, plus tested by qualified nozzle technicians, prior to placing it back in service.

NOTICE

- Do not use the nozzle as a forcible entry tool. Doing so may damage it or make it inoperable.

NOTICE

- If any tags or bands on the nozzle are worn or damaged and cannot be easily read, they should be replaced.

NOTICE

- For use with fresh water or standard firefighting foams only. Not recommended for use with salt water. After use with foam or salt water, flush with fresh water.

PHONE: 330.264.5678 or 800.228.1161 | FAX: 330.264.2944 or 800.531.7335

www.akronbrass.com



STYLE 4446 SELECTABLE FLOW NOZZLE INSTALLATION, OPERATING, AND MAINTENANCE INSTRUCTIONS

NOTICE

- When using with an eductor, make sure the nozzle is properly matched to the eductor. If they are not, the nozzle flow, pressure, and reach may be reduced or the eductor may shutdown. Do not throttle your nozzle with an eductor in the line. This can cause the eductor to shut down.

NOTICE

- The nozzle is configured for optimum performance. Do not alter in any manner.

NOTICE

- Drain the nozzle after use to prevent freeze damage.

Operating Instructions

NOZZLE & TIP

- To change the spray angle, rotate the pattern sleeve/bumper. Rotate it clockwise for straight stream and counter clockwise for wide fog.
- To flush the nozzle, rotate the flow control ring counterclockwise to the FLUSH setting. Rotate slowly back to the required setting when obstruction is flushed.
- Some nozzles have various flow settings indicated on flow control ring. To change the flow rate, slowly rotate the flow control ring to the required setting and adjust your engine to provide the rated pressure at the inlet of the nozzle.
- To determine the required engine pressures to achieve the flow setting, use the following formula: Engine pressure (EP) = Friction Loss (FL) + Nozzle Pressure (NP) + pressure loss or gains due to elevation (1/2 psi per foot of height difference).

FOR USE WITH CAFS

- For optimal CAFS Bubble Structure place the nozzle pattern in straight stream and turn the flow control ring to FLUSH.
NOTE: Changing the flow control ring without adjusting the pressure will affect your actual flow rate
 - i.e., If you change to a higher flow setting, your inlet pressure will decrease and your flow will be less than shown on the flow control ring. If you change to a lower flow setting, your inlet pressure will increase and your flow will be more than shown on the flow control ring. Changing the flow changes the reaction force. Pump curves, hose size and length, elevation, etc., will affect actual results.

Maintenance Instructions

- After use, flush the nozzle with clean water to clean grit and dirt from around exterior moving parts. Doing so will allow the nozzle to operate as designed.
- Over time the seals and turbine teeth may need replaced. This can be accomplished by purchasing the appropriate Akron repair kit. Use qualified maintenance mechanics or return the nozzle to Akron Brass for repair.
- Regularly check the baffle screw to be sure it is tight
- Use low temp Lubriplate on metal parts and Parker O-Ring lubricant on O-Rings.

WARRANTY AND DISCLAIMER*: We warrant Akron Brass products for a period of five (5) years* after purchase against defects in materials or workmanship. Akron Brass will repair or replace product which fails to satisfy this warranty. Repair or replacement shall be at the discretion of Akron Brass. Products must be promptly returned to Akron Brass for warranty service.

We will not be responsible for: wear and tear; any improper installation, use, maintenance or storage; negligence of the owner or user; repair or modification after delivery; failure to follow our instructions or recommendations; or anything else beyond our control. WE MAKE NO WARRANTIES, EXPRESS OR IMPLIED, OTHER THAN THOSE INCLUDED IN THIS WARRANTY STATEMENT, AND WE DISCLAIM ANY IMPLIED WARRANTY OF MERCHANTABILITY OR FITNESS FOR ANY PARTICULAR PURPOSE. Further, we will not be responsible for any consequential, incidental or indirect damages (including, but not limited to, any loss of profits) from any cause whatsoever. No person has authority to change this warranty.

© Akron Brass Company. 2019 All rights reserved. No portion of this can be reproduced without the express written consent of Akron Brass Company.

PHONE: 330.264.5678 or 800.228.1161 | FAX: 330.264.2944 or 800.531.7335

www.akronbrass.com